



August 2019

# POSO CREEK

Integrated Regional Water Management Plan | **2019 Update**



Semitropic Water Storage District  
1101 Central Ave., P.O. Box 8043  
Wasco, CA 93280

# **2019 Poso Creek Integrated Regional Water Management (IRWM) Plan Update**

*submitted and adopted by the*

Poso Creek Regional Water Management Group (RWMG)  
Led by the Semitropic Water Storage District  
Wasco, CA

*on behalf of the*

Poso Creek IRWM Group  
Kern and Tulare Counties, CA

*submitted to the*

California Department of Water Resources (DWR)  
Sacramento, CA

*in accordance with the*

Water Quality, Supply, and Infrastructure Improvement Act of 2014  
(Proposition 1)

- August 2019 -



## **POSO CREEK INTEGRATED REGIONAL WATER MANAGEMENT (IRWM) GROUP 2019 IRWM PLAN UPDATE SYNOPSIS**

The purpose of the original 2007 Poso Creek IRWM Plan, the first IRWM Plan completed and adopted by the Poso Creek IRWM Group, was to provide a framework for (1) coordinating groundwater and surface water management activities through *regional* objectives, and (2) implementing the measures necessary to meet those objectives. These statements reflected the aims of the IRWM Group to improve water resources management that benefits inhabitants throughout the Poso Creek Region (Region) as well as water purveyors in other parts of California while satisfying regional priorities. At the time, the priorities principally considered the Department of Water Resources' (DWR) IRWM Proposition 50 Program Guidelines and the Resource Management Strategies (RMSs) presented in the California Water Plan Update 2005. A 2014 Plan Update was later added that reflected the IRWM Group's expanded planning efforts to address requirements in the DWR's Proposition 84 IRWM Guidelines that focused on additional RMSs.

While the purposes and goals of these previous efforts remain, the 2019 IRWM Plan Update (Plan) reflects the IRWM Group's efforts to address new requirements in the DWR's Proposition 1 2016 IRWM Guidelines that outline additional RMSs, specifically focusing on regional water self-reliance and adapting to the effects of climate change as well as the integration of local Native American communities into the planning process. In the case of the Poso Creek IRWM region, no active Native American communities are known to exist within the Plan's region.

While this Plan was developed to compliment and expand upon the original 2007 Plan and 2014 Plan update, the overriding conclusions remain the same. That is, surface water supplies available through delivery to the Region have been largely unreliable, on an annual basis, and will likely remain unreliable (reduced) in the future relative to historical conditions. Given water users within the districts that are involved in the IRWM Groups' efforts are reliant on surface water sources delivered from outside the Region, it will likely lead to a corresponding decline in groundwater levels as groundwater is used to make up the reduction in surface water supplies if proactive actions are not taken. The economic, environmental, and social burdens of this scenario will be felt by *all users* that rely in whole or in part on pumped groundwater, including a significant portion of agricultural, environmental, and municipal (communities) users in the Region.

As a generalization, this Plan puts into context the planning and implementation efforts to address these concerns by the IRWM Group through the direction of the Regional Water Management Group (RWMG). The RWMG is comprised of the districts and agencies that consider and provide funding of the planning and implementation efforts. In addition to the RWMG, the IRWM Group includes other regional Stakeholders, members that are directly involved with or potentially affected by the planning and management efforts of the RWMG, Interested Parties, and public or private entities that have interest in the Poso Creek regional planning process but may or may not be directly involved. This Plan contains materials discussed in context to regional water management needs and concerns for the IRWM Group regarding the follow subjects:

- *RWMG and IRWM Group Governance*: Discusses the IRWM Group’s governance structure based on the agreements and management of the RWMG. Includes the decision making processes and outreach/involvement efforts used to facilitate participation in the IRWM Group by the RWMG, Stakeholders, and Interested Parties (public).
- *Regional Description*: Discusses the Poso Creek Region, including the water supply, quality, and demand situation, social and cultural makeup, and regional management objectives and conflicts which have led to the opportunity for regional water management activities.
- *Regional Goals and Measurable Objectives*: Discusses the IRWM Group’s Goals and Objectives, including quantitative and qualitative metrics for monitoring and achieving said Goals and Objectives. Development of the Goals and Objectives consider Statewide Priorities and Resources Management Strategies, as well as the primary resource concerns of regional water users (e.g., agricultural, environmental, municipal, etc.)
- *Projects and Programs Review Process*: Discusses the procedure by which any district, agency, organization, or individual can submit projects and programs to the IRWM Group for consideration. Includes the RWMG and IRWM Group review process, and the means by which the Group communicates the list of projects and programs which have been selected for inclusion in the IRWM Group’s planning and implementation efforts.
- *Impacts and Benefits*: Discusses the potential impacts and benefits of Plan implementation in the Region, to neighboring regions, with community (DAC), environmental, and economic concerns.
- *Plan Performance, Monitoring, and Data Management*: Discusses the performance measures and monitoring methods to ensure that the Plan Objectives are met. Includes details on the data needs of the IRWM Group and how the collected data is shared publically and with local, State, and Federal agencies.
- *Funding Opportunities*: Discusses the plans for implementation and financing of projects and programs, including the potential funding mechanisms (e.g., grant

funding support). The certainty and longevity of these funding sources is also discussed, as well as how to operate and maintain projects and programs once funding is no longer available.

- *Technical Analysis*: Discusses the technical analyses used in development of the Plan, with particular emphasis on the data and baseline conclusions from the original 2007 IRWM Plan and 2014 Plan update.
- *Relation to Water Resources and Land-Use Planning*: Discusses the relation of the Plan to other planning documents and programs in the Region, and how the IRWM Group coordinates with these planning efforts.
- *Stakeholder and Public Involvement*: Further discusses the means by which the IRWM Group facilitates participation in the regional planning and implementation activities, by the RWMG, Stakeholders, and Interested Parties. Emphases are placed on public participation and the participation of regional communities (DACs).
- *Coordination and Integration Standards*: Discusses the process by which the IRWM Group coordinates projects and programs with local agencies (Stakeholders and Interested Parties). Addresses neighboring IRWM Groups and cooperation efforts between inter-regional groups.
- *Climate Change Assessment*: Discusses an evaluation of the Region's vulnerabilities to the potential impacts of climate change and how these vulnerabilities are addressed by the IRWM Group when considering projects and programs (e.g., GHG emissions, environmental impacts, etc.)

Both structural projects and non-structural program enhancements are addressed in this Plan, while conforming to the stated Goals and Objectives. These provide the means for coordinating the assets, needs, and operations regarding water supplies and demands in the Region, with the end result being mitigated water concerns for the RWMG, Stakeholders, and Interested Parties.

The following pages (tables) acknowledge the participation of the individual districts, agencies, organizations, and individuals who make up the RWMG, Stakeholders, and Interested Parties of the Poso Creek IRWM Group. Each of the Boards of Directors of the districts that make up the RWMG have adopted the Plan and its contents, representing their continued participation in further developing, funding, and ultimately managing the IRWM Group. Note that the RWMG had also adopted the original 2007 IRWM Plan in July 2007, and the 2014 Plan update in June 2014. To that extent, the Plan should be considered a *living document* which may change in response to new information, changed conditions, or other factors.

## IRWM Participating Districts & Agencies

### Poso Creek RWMG Participants

District, Agency of Entity	Location	Special District Type <sup>1</sup>	Voting Rights	Funding Commit.
Semitropic (SWSD) <sup>2</sup>	Wasco, CA	Water Storage District	X	X
North Kern (NKWSD)	Bakersfield, CA	Water Storage District	X	X
Cawelo (CWD)	Bakersfield, CA	Water District	X	X
Shafter-Wasco (SWID)	Wasco, CA	Irrigation District	X	X
Kern-Tulare (KTWD)	Bakersfield, CA	Water District	X	X
Southern San Joaquin (SSJMUD)	Delano, CA	Municipal Utility District	X	X
Delano-Earlimart (DEID)	Delano, CA	Irrigation District	X	X
North West Kern (NWKRCDD)	Bakersfield, CA	Resource Conservation District	X	
Disadvantaged Community (DAC) Representative			X	

<sup>1</sup> Statutory authority for water supply and/or water management granted under the California Water Code.

<sup>2</sup> IRWM Leading Agency.

### Poso Creek IRWM Stakeholder Members

District, Agency of Entity	Location	CWC Category <sup>1</sup>
Rosedale-Rio Bravo Water Storage District	Bakersfield, CA	WP, GD
Buena Vista Water Storage District	Buttonwillow, CA	WP, GD
Lost Hills Utility District (LHUD)	Lost Hills, CA	GD
Lost Hills Water District (LHWD)	Lost Hills, CA	GD, WP
California Department of Water Resources (DWR)	Sacramento, CA	SF
U.S. Bureau of Reclamation (USBR)	Fresno, CA	SF
Kern County Water Agency (KCWA)	Bakersfield, CA	WP, SF
Kern National Wildlife Refuge	Wasco, CA	GD, ES

<sup>1</sup> Stakeholder and local agency categories as defined by the California Water Code §10541(g), see Plan Section 11.1.

Poso Creek IRWM Stakeholder Members (Continued)

<b>District, Agency of Entity</b>	<b>Location</b>	<b>CWC Category<sup>1</sup></b>
Semitropic Wildlife Improvement District	Wasco, CA	GD, ES
Friant Water Users Authority	Lindsay, CA	ES, CO
Tulare Basin Wildlife Partners	Three Rivers, CA	ES
<i>Cities and Unincorporated Communities<sup>2</sup></i>		
City of Delano	Delano, CA	GD, CO, DC
City of McFarland	McFarland, CA	GD, CO, DC
City of Shafter	Shafter, CA	GD, CO, DC
Community of Buttonwillow	Buttonwillow, CA	CO, DC
Community of Earlimart	Earlimart, CA	CO, DC
Community of Lost Hills	Lost Hills, CA	CO, DC
Community of Richgrove	Richgrove, CA	CO, DC
Community of Madonna (Unincorporated)	Madonna, CA	CO, DC
Community of Pond (Unincorporated)	Pond, CA	CO, DC
Community of North Shafter (Unincorporated)	Shafter, CA	CO, DC
Community of South Shafter (Unincorporated), including Smith's Corner, Thomas Lane, Cherokee Strip, Burbank, Mexican Colony, and Southwest Shafter	Shafter, CA	CO, DC
Pond Union School District	Wasco, CA	SS
Semitropic School District	Wasco, CA	SS
Maple Elementary School	Shafter, CA	SS
Rodriguez Farm Labor Camp	Richgrove, CA	OT
Community of Allensworth (Unincorporated)	Allensworth, CA	CO, DC

<sup>1</sup> Stakeholder and local agency categories as defined by the California Water Code §10541(g), see Plan Section 11.1.

<sup>2</sup> All incorporated cities and communities are considered Disadvantaged Communities (DACs), represented by both the DAC Representative (see RWMG Participants table) and a DAC Workgroup; see Plan Section 3.9.

Poso Creek IRWM Stakeholder Members (Continued)

<b>District, Agency of Entity</b>	<b>Location</b>	<b>CWC Category<sup>1</sup></b>
<i>Cities and Unincorporated Communities</i> <sup>2</sup>		
Community of Alpaugh (Unincorporated) <sup>3</sup>	Alpaugh, CA	CO, DC
Community of Ducor (Unincorporated) <sup>3</sup>	Ducor, CA	CO, DC
<i>Individuals</i>		
Kathy Wood McLaughlin, Tulare Basin Watershed Coordinator	Fresno, CA	ES
Carole Combs, Tulare Basin Wildlife Partners	Three Rivers, CA	ES

<sup>1</sup> Stakeholder and local agency categories as defined by the California Water Code §10541(g), see Plan Section 11.1.

<sup>2</sup> All incorporated cities and communities are considered Disadvantaged Communities (DACs), represented by both the DAC Representative (see RWMG Participants table) and a DAC Workgroup; see Plan Section 3.9.

<sup>3</sup> Located outside of Poso Creek IRWM Region.

Poso Creek IRWM Interested Parties

<b>District, Agency of Entity</b>	<b>Location</b>	<b>CWC Category<sup>1</sup></b>
U.S. Department of Agriculture: Natural Resource Conservation Service (USDA – NRCS)	Bakersfield, CA	SF, ES
Fresno State University: California Water Institute	Fresno, CA	SF
Kern River Watershed Coalition Authority	Fresno, CA	ES, CO
Kern County Board of Supervisors	Bakersfield, CA	GD
County of Kern Engineering Services	Bakersfield, CA	GD
California Department of Fish and Wildlife	Sacramento, CA	SF, ES
Wonderful Farms	Lost Hills, CA	IO
Community Water Center	Visalia, CA	CO
<i>Individuals</i>		
Mathew Hurley, Angiola Water District	Corcoran, CA	WP, GD
Denise Akins, County of Tulare	Visalia, CA	GD
<i>Misc. 'Public Interest' including Landowners, Environmental Advocacy Groups, Private/ Public Organizations, etc.</i>		CO, OT



## Table of Contents

	Plan Synopsis	I
	IRWM Participating Districts & Agencies (Tables)	IV
	Table of Contents	V
	List of Figures	IX
	List of Tables	XI
	List of Acronyms	XII
1.0	Introduction	1-1
	1.1 Regional Overview	1-3
	1.2 Purpose and Scope	1-4
	1.3 Plan Update and Organization	1-5
2.0	Governance	2-1
	2.1 Statutory and Regulatory Authority	2-2
	2.2 Governance Structure	2-3
	2.3 Work Groups	2-6
	2.4 Decision-Making Process	2-7
	2.5 Plan Development	2-8
	2.6 Plan Adoption and Implementation	2-9
	2.7 Coordination with Neighboring IRWM Efforts, State and Federal Agencies	2-10
3.0	Regional Description	3-1
	3.1 Regional Water Supplies	3-2
	3.2 Dependence on Supplemental Surface Water Supplies	3-4
	3.3 Dependence on Groundwater Supplies	3-6
	3.4 Regional Water Demands	3-8
	3.5 Watersheds and Water Systems	3-12
	3.6 Water Quality Conditions	3-20
	3.7 Ecological Processes and Environmental Resources within Region	3-39
	3.8 Water-Related Recreation Land Use	3-42
	3.9 Urban and Industrial Lands and Disadvantaged Communities	3-43
	3.10 Social, Cultural, and Economic Trends of the Region	3-48
	3.11 Appropriateness of the Region for an IRWM Plan	3-49
4.0	Regional Goals and Measurable Objectives	4-1
	4.1 Regional Vision and Mission	4-2
	4.2 Previous Plan Objectives	4-2
	4.3 Goals and Objectives Development Process	4-3
	4.4 Regional Goals	4-5
	4.5 Measurable Objectives	4-6
	4.6 Regional Goal and Measurable Objective Linkage	4-8
	4.7 Statewide Program Preferences	4-16

## Table of Contents (Continued)

4.8	Resource Management Strategies	4-18
4.9	Other Strategies	4-31
4.10	Stakeholder, Agency, and Public Involvement	4-32
5.0	Projects and Programs Review Process	5-1
5.1	Identification and Submittal of Projects and Programs	5-2
5.2	Compliance with Measurable Objectives	5-6
5.3	Funding Opportunities	5-7
5.4	Other Considerations	5-8
5.5	Maintenance of Project and Program List	5-9
6.0	Impacts and Benefits	6-1
6.1	General and Economic Benefits of Regional Water Management	6-2
6.2	Plan Impacts and Benefits	6-3
6.3	Resource Management Strategies	6-4
6.4	State and Federal Stakeholders	6-12
6.5	Stakeholders, Interested Parties, and Disadvantaged Communities	6-12
6.6	Project and Program Specific Assessment	6-13
7.0	Plan Performance, Monitoring, and Data Management	7-1
7.1	IRWM Measurable Objectives	7-1
7.2	Implementation of IRWM Projects and Programs	7-2
7.3	Project and Program Specific Monitoring	7-2
7.4	Data Collection and Management	7-4
7.5	Data Sharing and Compatibility with Agency Databases	7-8
8.0	Funding Opportunities	8-1
8.1	Funding Plan Activities	8-2
8.2	Federal, State, and Local Funding Sources	8-5
8.3	Funding Certainty and Longevity	8-5
8.4	Funding Project and Program Operation and Maintenance	8-7
9.0	Technical Analysis	9-1
9.1	Surface Water Use	9-2
9.2	Land Use	9-3
9.3	Groundwater Levels	9-3
9.4	Absorptive Capacity	9-4
9.5	Projected Availability of Surface Water Supplies	9-5
9.6	Projected Change in Water Demand	9-6
9.7	Projected Change in Use of Surface Water Supplies	9-7

## Table of Contents (Continued)

10.0	Relation to Water Resources and Land-Use Planning	10-1
10.1	Local Water Planning and Management	10-1
10.2	Regional Water Planning and Management	10-7
10.3	Local Water and Land-Use Planning Efforts	10-13
11.0	Stakeholder and Public Involvement	11-1
11.1	Regional Stakeholders & Interested Parties	11-1
11.2	State, Federal, and Local Stakeholders	11-4
11.3	Other Stakeholders and Disadvantaged Communities	11-5
11.4	Public Involvement and Outreach	11-6
11.5	Continuous Outreach and Involvement Strategies	11-7
12.0	Coordination and Integration Standards	12-1
12.1	Coordination and Integration in IRWM Group Activities	12-2
12.2	Resource Integration	12-2
12.3	State and Federal Agency Assistance	12-3
12.4	Neighboring IRWM Regions	12-3
13.0	Climate Change Assessment	13-1
13.1	Effects of Climate Change on Regional Water Supplies	13-2
13.2	Effects of Climate Change on Agricultural Water Demand	13-3
13.3	Regional Vulnerability Assessment	13-4
13.4	Mitigation of Greenhouse Gas Emissions	13-14
13.5	Climate Change Response and Monitoring Efforts	13-15
14.0	References	14-1

## Table of Contents (Continued)

### *Appendices*

- A Poso Creek IRWM Group Projects and Programs Lists
  - A1 Project and Program Report List (Historical) and IRWM Report Card
  - A2 Plan Project and Program List
- B Description of RWMG Participants of the IRWM Group
- C Memorandum of Understanding (MOU) for the RWMG
- D Public Notices for the IRWM Plan Update
- E Resolution of IRWM Plan Update Adoption by the RWMG
- F Poso Creek Regional Water Demand and Supply Analyses from the 2007 IRWM Plan
  - F1 Chapter 4: Historical and Projected Water Supplies
  - F2 Chapter 5: Historical Water Use and Projected Water Demand
  - F3 Chapter 7: Water Supply Operations Studies
- G Project Definition and Characterization Form (PDCF)
- H Poso Creek IRWM Public Involvement Plan (PIP)
- I Kern County Storm Water Resource Plan
- J Drought Contingency Plan

## List of Figures

		<i>Section</i>	
1.1	Poso Creek IRWM Group Structure	1.0	1-1
1.2	Poso Creek IRWM Region (View #1)	1.0	1-2
1.3	Poso Creek IRWM Region (View #2)	1.0	1-2
1.4	Regional Boundaries in Relation to Groundwater Basin Boundaries	1.1	1-3
2.1	Poso Creek IRWM Group Organization Chart	2.2	2-5
3.1	Water Distribution Network and Conveyance Infrastructure	3.5	3-16
3.2	Constructed Spreading Ponds for Groundwater Recharge	3.5	3-18
3.3	Typical Groundwater Well Discharging to a Main Conveyance Channel	3.5	3-19
3.4	Critical Habitat Conservation Areas	3.7	3-40
3.5	Kern National Wildlife Refuge	3.7	3-41
3.6	Isabella Reservoir Recreational Area	3.8	3-42
3.7	Locations of DACs in the Poso Creek Region	3.9	3-49
3.8	Relationship of RWMG to Poso Hydrologic Unit	3.11	3-51
4.1	Regional Framework and IRWMP Planning Hierarchy	4.3	4-4
4.2	Poso Creek IRWM Regional Goals	4.4	4-5
4.3	Poso Creek IRWM Measurable Objectives	4.5	4-6
4.4	Connections between Measurable Objectives and Regional Goal No. 1	4.6	4-8
4.5	Connections between Measurable Objectives and Regional Goal No. 2	4.6	4-10
4.6	Connections between Measurable Objectives and Regional Goal No. 3	4.6	4-11
4.7	Connections between Measurable Objectives and Regional Goal No. 4	4.6	4-12
4.8	Connections between Measurable Objectives and Regional Goal No. 5	4.6	4-13
4.9	Connections between Measurable Objectives and Regional Goal No. 6	4.6	4-14
4.10	Connections between Measurable Objectives and Regional Goal No. 7	4.6	4-16
4.11	IRWMP Planning Structure	4.10	4-32
5.1	IRWM Plan Projects and Programs Identified in the Poso Creek Region	5.1	5-3
5.2	Projects and Program Submission and Review Process	5.1	5-5
9.1	Annual Fluctuations in Surface Water Supplies Delivered to the Region	9.1	9-2
9.2	Annual Fluctuations of Irrigated Acreage in the Region	9.2	9-3

## List of Figures (Continued)

		<i>Section</i>	
9.3	Annual Fluctuations of Average Depths to Groundwater in the Region	9.3	9-4
9.4	Average Monthly Absorptive Capacity in the Region	9.4	9-5
13.1	Regional Climate Change Planning Structure	13.5	13-17

## List of Tables

		<i>Section</i>	
3.1	Historical Baseline and Projected Availability of Surface Water Supplies	3.1	3-3
3.2	Projected Availability of SWP Water with and without Climate Change	3.1	3-4
3.3	Groundwater Basins	3.3	3-7
3.4	Irrigated Area in Poso Creek Region in 2013	3.4	3-9
3.5	Crop Pattern for Poso Creek Region	3.4	3-9
3.6	Actual (2010) and Projected Gross Use of Water for M&I Purposes	3.4	3-11
3.7	Characteristics of the Region’s Disadvantaged Communities	3.9	3-46
4.1	Measurement Metrics for Poso Creek IRWM Measurable Objectives	4.5	4-7
4.2	IRWM Program Preferences	4.7	4-16
4.3	IRWMP Resource Management Strategies	4.8	4-19
4.4	IRWMP Miscellaneous Strategies	4.9	4-31
6.1	Screening-Level Assessment of Impacts and Benefits of IRWMP Resource Management Strategies	6.3	6-5
7.1	Data Needs, Collection, and Management List	7.4	7-5
8.1	IRWM Group Planning and Implementation Financing Table Format	8.1	8-4
10.1	Status Summary of Local Water Planning Efforts (Year Adopted)	10.1	10-2
10.2	Summary of Regional Water Planning Efforts by Local Entities	10.2	10-7
13.1	IRWMP Climate Change Vulnerability Assessments	13.3	13-5
13.2	IRWMP Climate Change Vulnerability Assessment Score-Sheet	13.3	13-14

## List of Acronyms

ACS	American Community Survey
AWMP	Agricultural Water Management Plan
BDCP	Bay-Delta Conservation Plan
BMO	Basin Management Objective
CASGEM	California Statewide Groundwater Elevation Monitoring ( <i>DWR</i> )
CASWSC	California Water Science Center ( <i>USGS</i> )
CDPH	California Department of Health
CEQA	California Environmental Quality Act
CIMIS	California Irrigation Management Information System ( <i>DWR</i> )
COG	Council of Governments
CVC	Cross Valley Canal
CVP	Central Valley Project ( <i>Federal – USBR</i> )
CVPIA	Central Valley Project Improvement Act
CVRWQCB	Central Valley Regional Water Quality Control Board
CWC	California Water Code
DAC	Economically-Disadvantaged Community
DAMS	Department of Agriculture and Measurement Standards ( <i>Kern County</i> )
DMS	Data Management System
DWR	California Department of Water Resources
ESR	Endangered Species Recovery ( <i>Program</i> )
FMMP	California Farmland Mapping and Monitoring Program
FWA	Friant Water Authority
GHG	Greenhouse Gases ( <i>Emissions</i> )
GIS	Geographic Information System
GWMP	Groundwater Management Plan
HCP	Habitat Conservation Plan
ID	Irrigation District
ILRP	Irrigated Lands Regulatory Program
IRWM	Integrated Regional Water Management ( <i>Plan or Group</i> )
IRWMG	Integrated regional Water Management Group
IRWMP	Integrated Regional Water Management Plan
JPA	Joint Powers Authority
KCAD	Kern County Agricultural Department
KCWA	Kern County Water Agency
KGWMC	Kern Groundwater Management Committee
KCWRC	Kern County Water Resources Committee
KGWMC	Kern Groundwater Management Committee
KNWR	Kern National Wildlife Refuge
KRWCA	Kern River Watershed Coalition Authority
LAFCO	Local Agency Formation Commission



## List of Acronyms (Continued)

M&I	Municipal and Industrial ( <i>Water Uses</i> )
MHI	Median Household Income
MOU	Memorandum of Understanding
NEPA	National Environmental Policy Act
NWKRCDD	North West Kern Resource Conservation District
NRCS	Natural Resource Conservation Service ( <i>USDA</i> )
NWS	National Weather Service
PDCF	Project Definition and Characterization Form ( <i>Submission Form</i> )
PIP	Public Involvement Plan ( <i>Appendix G</i> )
QA/QC	Quality Assurance and Quality Control Measures
RMA	Regional Management Agency ( <i>changed to RWMG</i> )
RMG	Regional Management Group ( <i>changed to RWMG</i> )
RMS	Resource Management Strategy
RWMG	Regional Water Management Group
SDAC	Severely Disadvantaged Community ( <i>DAC</i> )
SHE	Self-Help Enterprises, LLC.
SWP	State Water Project ( <i>State – DWR</i> )
SWRCB	California State Water Resources Control Board
TBWP	Tulare Basin Wildlife Partners
USACE	US Army Corps of Engineers
USBR	US Bureau of Reclamation
USCID	US Committee on Irrigation and Drainage
USDA	US Department of Agriculture
USGS	US Geological Survey
UWMP	Urban Water Management Plan
WCP	Water Conservation Plan
WD	Water District
WMP	Water Management Plan
WSD	Water Storage District

For more information regarding the planning and implementation efforts of the Poso Creek Integrated Regional Water Management (IRWM) Group, as well as archived versions of past planning documents, please visit the IRWM Group website located at:

**[www.semitropic.com/PosoCreekIRWM.html](http://www.semitropic.com/PosoCreekIRWM.html)**

The website is managed and maintained by the Semitropic Water Storage District, the IRWM Group Lead Agency.

## 1.0 Introduction

The Poso Creek Regional Water Management Group (RWMG) formed in 2005 as a group financed by individual water management districts (RWMG Participants) in the northern Tulare Lake region of Kern County. The RWMG formed the Poso Creek Region (Region) based on the individual districts having an interest in developing a collaborative approach to regional water management.

Following a defined Vision and Mission (Section 4.1), the RWMG ultimately developed and adopted an Integrated Regional Water Management Plan (IRWM Plan or IRWMP) in 2007 that articulated Planning Objectives and identified a list of structural (project) and non-structural (program) enhancements for the Region to improve water management between the RWMG Participants. The 2007 IRWMP followed the applicable State standards for IRWM planning, including IRWMP Proposition 50 Program Guidelines and the California Water Plan Update 2005. At that time, the RWMG had effectively formed an Integrated Regional Water Management Group (IRWMG or IRWM Group) that, in addition to the RWMG, included other Stakeholders, which includes members that are directly involved with or potentially affected by the planning and management efforts of the RWMG, and Interested Parties, which includes any public or private entities that have interest in the Poso Creek regional planning process but may or may not be directly involved. A diagram of the IRWM Group structure is shown in Figure 1.1, and further explained in Section 2.2.

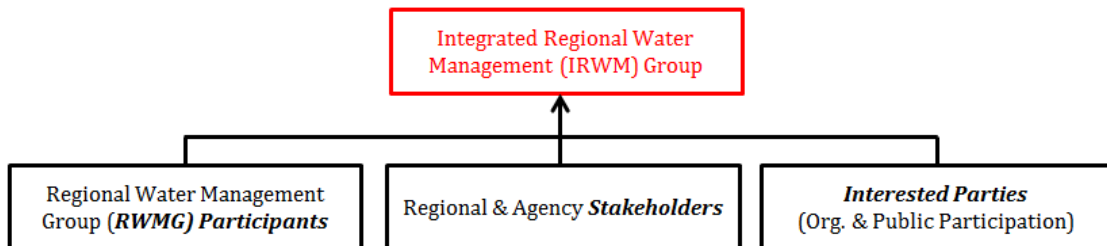
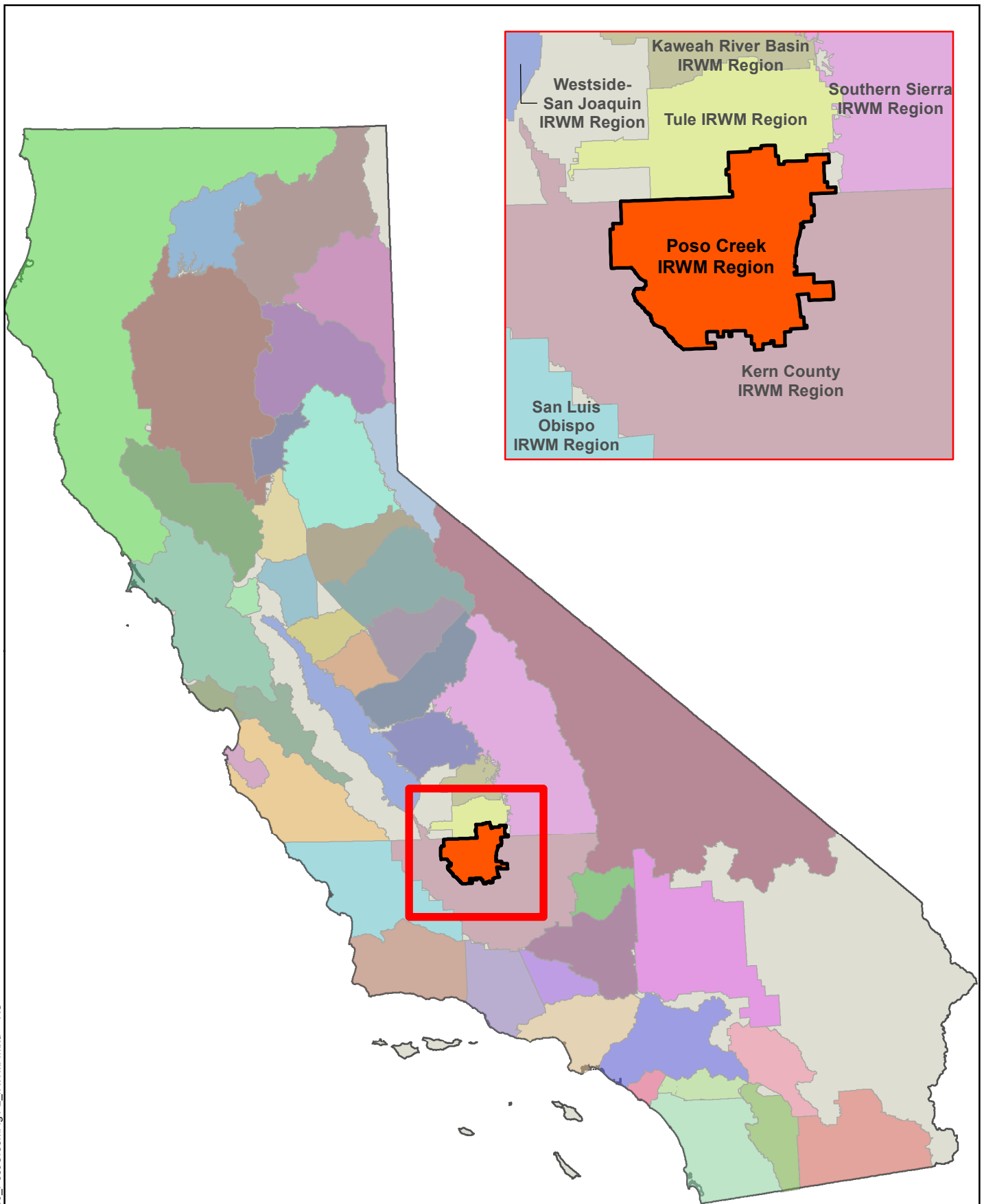

**Figure 1.1** Poso Creek IRWM Group Structure

A listing of all active members of the IRWM Group, as of January 2019, is identified in the ‘IRWM Participating Districts & Agencies’ tables at the beginning of the Plan. Two views of the Region showing entities within and near the Poso Creek IRWMP Boundary are presented in Figure 1.2 and Figure 1.3.

Although individual members in each category of the IRWM Group have somewhat changed since adoption of the 2007 IRWMP, a strong collaborative effort remains between those involved in the planning process to enhance regional water management through projects and programs that conform to current IRWMP Program Guidelines and are eligible for State and Federal grant funding. Since the original adoption, the 2007 Plan was updated in 2014 in

compliance with the IRWMP Proposition 84 Program Guidelines and is now being revised per 2016 Proposition 1 IRWMP Program Guidelines. As such, the RWMG has developed and adopted a 2019 IRWM Plan Update (Plan Update) to clarify management and planning efforts that have evolved since 2007 and to conform with new State standards for IRWMPs applicable to IRWMP Proposition 1 Program Guidelines. The following sections provide an overview of the IRWM Group and their objectives with the development and adoption of a 2019 Update of the Poso Creek IRWMP.



Z:\Projects\1332150\_PosoCreek\Fig1-2\_IRWMP.mxd RS  
15-May-2014

SOURCE: DWR Bulletin 118, v.3, 2003.

2019 Integrated Regional Water  
Management Plan (IRWMP) Update  
Kern and Tulare Counties, California

Poso Creek IRWM Group



POSO CREEK IRWMP REGION

JAN 2019

FIGURE 1.2

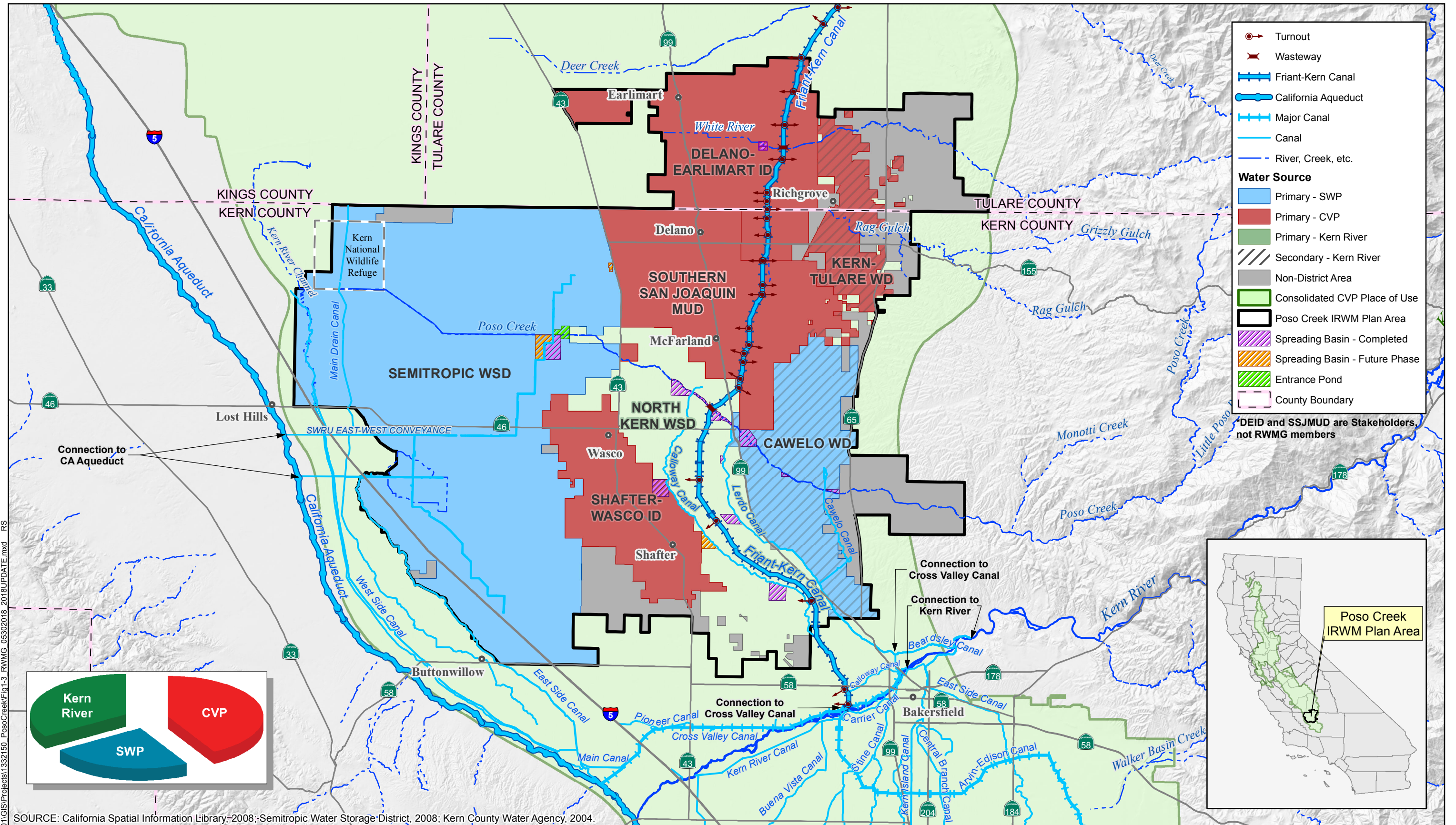

SOURCE: California Spatial Information Library, 2008; Semitropic Water Storage District, 2008; Kern County Water Agency, 2004.

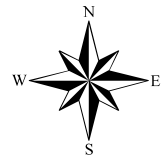
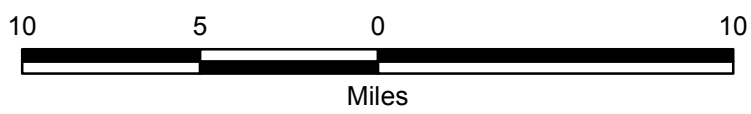

Poso Creek IRWM Plan, 2018 Update  
Southern San Joaquin Valley, California

Poso Creek IRWM Plan Area (Region)



REGIONAL WATER MANAGEMENT GROUP

JUNE 2018

FIGURE 1.3

01-May-2014 \\sac1s-f01\GIS\Projects\1332150\_PosoCreek\Fig1-3\_RWMG\_05302018\_2018UPDATE.mxd RS

## 1.1 Regional Overview

The Region is located at the southern end of the San Joaquin Valley, a physiographic trough surrounded by a horseshoe-shaped ring of mountains with the Sierra Nevada Mountains to the east and a series of coastal mountains to the west. In this semi-arid Region, “summers” (April through October) are typically hot and dry with no significant precipitation (i.e., total precipitation generally around 0.5 – 1.5 inches), while winters (November through March) are typically cooler and are characterized by frequent fog with some minor precipitation (i.e., total precipitation generally around 5 – 7 inches). The topography consists primarily of flat land (around 90 percent of the Region), with a mild westerly slope.

Irrigated agriculture is the dominant land use in the Region. Prior to formation of the agricultural water management districts, including the districts who are RWMG Participants, water for irrigation was obtained almost exclusively from groundwater sources, resulting in a rapid decline in static groundwater levels. It is noted that the groundwater basin common to the Region is the San Joaquin Valley Groundwater Basin (DWR No. 5-22), with most of the Region falling within the “Kern County Subbasin” (DWR No. 5-22.14). The delineation of basin boundaries was presented in DWR Bulletin 118, and these boundaries are shown with respect to the Region in Figure 1.4. To mitigate the impacts of declining groundwater levels, these districts were formed to provide public entities for entering into contracts for the use of supplemental surface water supplies delivered from State, Federal, and/or local watershed sources. Principal sources of surface water supply to the Region include the Kern River (local); Poso Creek (local); State Water Project, or SWP (state) with deliveries via the California Aqueduct; and the Central Valley Project, or CVP (federal) with deliveries via the Friant-Kern Canal and the California Aqueduct. In this regard, refer to Figure 1.1 for the locations of the main conveyance facilities, and to Section 3.3 for additional discussion.

Numerous public agencies, formed under the laws of the State of California (State), were established to develop, regulate, and distribute local water supplies and supplies imported from other areas of the State via the SWP and CVP. For decades, water districts and agencies around the State, including the RWMG Participants, have given much attention, effort, and funding to the effective planning and management of the available water resources.

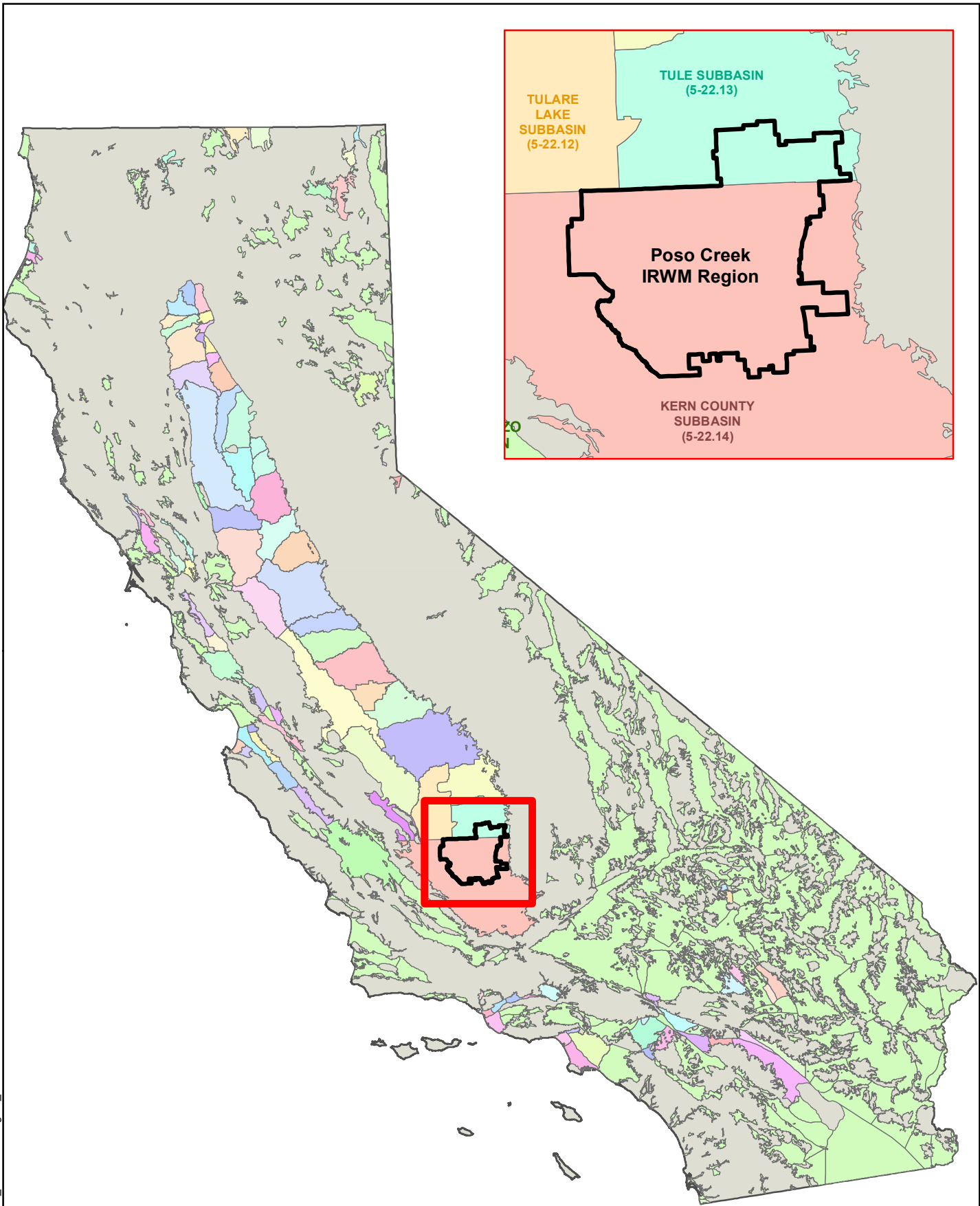

SOURCE: DWR Bulletin 118, v.3, 2003.

2014 Integrated Regional Water Management Plan (IRWMP) Update  
Kern and Tulare Counties, California

Poso Creek IRWM Group



REGIONAL BOUNDARY IN RELATION TO GROUNDWATER BASIN BOUNDARIES

JUNE 2014

FIGURE 1.4

15-May-2014 Z:\Projects\1332150\_PosoCreek\Fig1\_4\_GWBasins.mxd RS



The agricultural-based economy of the Region, which has a large economic influence in Kern County (Section 3.1), depends on adequate water supplies from a combination of local and imported surface water supplies and the underlying groundwater resources. However, shortages in available surface water supplies have been more frequent and larger than originally envisioned, largely due to regulatory restrictions on State and Federal deliveries of imported water supplies. Accordingly, water users in the Region are relying more heavily on groundwater pumping to meet water demands which, over time, may lead to groundwater level declines comparable to those which preceded the importation of supplemental surface water supplies. With climate change and increased competition for California’s water resources from urban and environmental uses threatening to decrease available supplies even further, the individual districts identified and understand the need for regional, multi-district and agency water management to address both current and impending water resource issues.

To date, the regional approach taken by the IRWM Group has led to the successful completion of over \$151 million in planning and project/program implementation activities to enhance water resources management and thereby mitigate the actual and anticipated reductions to surface water supplies delivered to the Region (see IRWM Projects and Programs lists in Appendix A). According to the 2007 IRWM Plan, the *reduction* in surface water supplies diverted into the Region could average on the order of 100,000 AF/year or more (as compared to historical levels of diversion and use). Continuous and adaptive regional planning and implementation efforts have helped to increase water use effectiveness in the Region through greater absorption and groundwater recharge and have helped to alleviate some of the water resources issues that are otherwise unresolvable and unmanageable under an individualized district planning focus.

## 1.2 Purpose and Scope

The purpose of the original 2007 IRWMP was to provide a framework for (1) coordinating groundwater and surface water resource management activities into a cohesive set of regional water management objectives, and (2) implementing the actions necessary to meet those objectives. The 2014 Plan Update reflected the IRWM Group’s expanded planning efforts to address requirements in the DWR’s Proposition 84 IRWM Guidelines that focused on additional resource management strategies and the IRWM Plan Standards as follows:

1. Coordination of comprehensive resource management activities for surface water, groundwater, environmental, and municipal into a cohesive set of Regional Goals and Measurable Objectives (reference Sections 4.4 and 4.5, respectively).
2. Evaluation and adaptation of the RWMG’s Measurable Objectives, including Mission/Vision, Regional Goals and their compliance with State planning requirements for considering Program Preferences, Statewide Priorities, and Resource Management Strategies.

3. Assessment of structural (project) and non-structural (program) enhancements that conform to the Measurable Objectives, leading to eventual implementation by the IRWM Group.

While the purposes of the original Plan and 2014 Plan update remain, the 2019 Plan Update aims to additionally focus on:

4. The recent addition of a voting member, Southern San Joaquin Municipal Utility District, to the RWMG.
5. The 2016 IRWM Plan Standards (intended to improve regional water security, drought preparedness, regional water self-reliance, and adaption to climate change.)

Anticipating the need for funding assistance in order to implement the identified enhancements, this Plan Update is prepared in satisfaction of eligibility requirements for grant funding administered by the State under Proposition 1. Whereas the 2007 IRWMP adhered to the groundwater monitoring and assessment emphases of the then applicable Proposition 50 Guidelines, and the 2014 Plan Update illustrated the expansion to more generalized resource management planning within the Region, the 2019 Plan Update includes more focus on water security, environmental and climate change impact assessment, and social and economic impacts of implemented projects and programs.

### **1.3 Plan Update and Organization**

The IRWM Plan was updated by the IRWM Group for the following reasons, according to the 2016 IRWM Plan Standards:

1. Reflect the California Water Plan Update 2013, specifically the addition of new Resource Management Strategies.
2. Include consideration of Native American Tribes in Governance Standard (not currently applicable for the Region, as there are no known tribal communities in the Region, which the IRWM Group confirmed in 2019).
3. Accommodate revisions to the Climate Change Standard.
4. Incorporate new requirements including AB 1249 on contamination of nitrate, arsenic, perchlorate, or hexavalent chromium, SB 985 on incorporation of a Storm Water Resource Plan, and requirements for economically distressed areas.
5. Consider the changes in water related needs of RWMG Participants, Stakeholders, and Interested Parties.

The vision for the 2019 Plan Update, along with preparation of the Plan Update, was the result of the IRWM Group working in concert with its consultant, GEI Consultants, Inc. During preparation of the Plan Update, the Plan Standards and relevant topics were routinely discussed during periodic (public) meetings of the RWMG. Each section of the Plan Update was made available for review

by the RWMG prior to release of the public review draft. It is noted that \$250,000 was provided by the DWR under a *2016 Proposition 1 Integrated Regional Water Management (IRWM) Planning Grant* for the 2019 Plan Update.

The Plan Update is organized such that the sixteen IRWM Plan Standards, set forth in the IRWMP Proposition 1 Guidelines, are fully addressed in a document that provides a clear description of regional conditions, resource management, and planning activities. The Update covers the standard 20-year planning horizon for IRWMPs and extends regional assessments for surface water and groundwater supplies and potential climate change impacts into the future. Each of the sections which follows addresses one or more of the Plan Standards, and the beginning of each section includes a table which clearly indicates the Plan Standards and Plan Standard Requirements which are addressed in that particular section, including identification of the subsection(s) where each requirement is addressed.

## 2.0 Governance

In accordance with the IRWMP Proposition 1 Program Guidelines, this section addresses the ‘Governance’ Plan Standard, which includes the requirements shown in the following table (along with identification of the specific subsection(s) where each requirement is addressed).

<b>Requirement</b>	<b>Plan Section(s)</b>
Name of RWMG and individual proponents responsible for implementation and adoption of IRWMP.	2.0, 2.1, 2.2
Description of RWMG, including discussion of how RWMG makeup satisfies CWC §10539, and is sufficient in breadth of membership and participation to develop and implement IRWMP.	2.2, 2.3, 2.4
Description of IRWM governance structure (including participation of Native American tribes).	2.2
Governance addresses public outreach and involvement process.	2.2, 2.3
Governance addresses effective decision making.	2.4
Governance addresses balanced access and opportunity for participation in IRWM process.	2.2, 2.3
Governance addresses effective communication internal and external to IRWM region.	2.2, 2.7
Governance addresses long-term implementation of IRWM Plan.	2.6
Governance addresses coordination with neighboring IRWM efforts and State/Federal agencies.	2.7
Governance addresses collaborative process used to establish plan objectives.	2.5
Governance addresses interim changes and formal changes to the IRWM Plan will be performed.	2.6
Governance addresses updating or amending the IRWM Plan.	2.6
Publish NOI to prepare/update the plan; adopt the plan in public meeting.	2.3, 2.6

The RWMG is organized under a Memorandum of Understanding (MOU) which was executed by the RWMG (water management districts and agencies as discussed in Section 1.0 and further described in Appendix B). In addition to the MOU structure, governance relies on the effectiveness of the individual leaders within each of the participating groups, which includes the RWMG Participants, Stakeholders, and Interested Parties, their roles and responsibilities, communication between these groups, and contributions through established relationships between all participants. The following section describes the RWMG governance structure, including communication protocols and decision-making policies. The latest version of the MOU with attached amendments, which contains a more detailed governance description, is found in Appendix C.

## 2.1 Statutory and Regulatory Authority

Each of the districts in the RWMG has statutory authority over water supply or water management within their designated ‘service areas’ consistent with their enabling legislation. These responsibilities may include distribution and management of water supplies, water quality management, flood control, etc. As such, the districts may exercise certain powers regarding the management of water supplies for beneficial uses and may take legal action needed to protect or prevent interference with water, the quality thereof, or water rights within the district boundaries (CWC §60220 through §60231). Note that water supplies are defined as water which is delivered to district water management facilities for the purposes of agricultural, environmental, municipal and industrial uses, as well as groundwater recharge and water transfer and exchange. Agricultural water supply, primarily for crop irrigation, includes the volume of water delivered to a district’s service area from both surface water and groundwater sources. It is worth noting that, following extensive public education and landowner election, each district or agency was formed by and for the benefit of all landowners within the organized (service) area. These districts continue to be governed by ‘Boards of Directors’ comprised exclusively of landowners, maintaining the direct relationship between formal water management and district users. District-specific authorities and rules/regulations for the distribution and protection of water supplies can be found in operational guideline documents adopted by a district’s Board of Directors and available from the public agencies, commonly titled “Rules and Regulations for Distribution and Use of Water” or similar. Recall that brief descriptions of each of the RWMG districts are given in Appendix B.

As previously mentioned the RWMG was formed under and is governed by an MOU between the water management districts and agencies listed in the ‘IRWM Participating Districts & Agencies’ tables at the beginning of the Plan. The RWMG includes ‘Water Storage Districts’, ‘Water Districts’, ‘Irrigation Districts’, one ‘Municipal Utility District’, and one ‘Resource Conservation District’ as defined by the CWC. The MOU, executed on May 12, 2010, formalized the governance of the RWMG. A First Amendment to the MOU was signed as part of the 2014 Plan Update in order to reflect the updated IRWMP’s Regional Goals and Measurable Objectives. A Second Amendment to the MOU was signed as part of the 2019 Plan Update for the addition of Southern San Joaquin Municipal Utility District (copies included with MOU in Appendix C) The Poso Creek RWMG meets the definition per the CWC §10539 since it includes: (1) more than three local agencies; (2) at least two local agencies that have statutory authority over water supplies or water management; and (3) members that participate by means of a written agreement (in this case, an MOU) that was approved by the governing bodies of the local agencies.

The purpose of the agreement was “to provide for the governance of the RWMG for the study, promotion and development of water management-related projects and programs and to encourage and facilitate design, financing, acquisition, construction and/or operation of same by some or all of the participating groups” (RWMG Participants, Stakeholders, and Interested Parties). The MOU identifies these purposes as powers of the RWMG. The RWMG is not

authorized to supersede any district-specific authorities for water management or to finance, acquire, construct or operate projects on behalf of any, or all, of the participating groups.

## 2.2 Governance Structure

The RWMG consists of nine voting members, including Semitropic (SWSD), North Kern (NKWSD), Cawelo (CWD), Shafter-Wasco (SWID), Kern-Tulare (KTWD), Delano-Earlimart (DEID), North West Kern (NWKRCDD), Southern San Joaquin (SSJMUD) and a representative for *economically-disadvantaged communities* (DACs) as part of the RWMG’s DAC Work Group (Poso Creek Region Disadvantaged Communities Group). These are also shown in the tables at the beginning of the Plan, under ‘RWMG Participants.’ Each of the RWMG Participants, as well as the DAC Work Group, has participated throughout the development of the Plan through periodic meetings; each has formally adopted the Plan; and each member continues to participate during the ongoing implementation phase. The NWKRCDD and DAC Representative participate in the RWMG at no cost.

The RWMG’s primary roles and responsibilities include:

- Execute and maintain the governance structure including the MOU;
- Maintain, update, and adopt an IRWM Plan;
- Designate a ‘Chairperson’ as representative with clear authority to represent the RWMG;
- Facilitate public meetings/workshops for regional planning efforts;
- Effectively communicate, both as one-way and two-way efforts, with the different functional groups within the RWMG, project proponents, local agencies, IRWM stakeholders, neighboring RWMGs, government agencies, and the public;
- Ensure balanced opportunity for the participation of any entity in the RWMG, irrespective of their financial contribution to the IRWM Plan;
- Call for, review, vet, and submit regional structural (projects) and non-structural (programs) enhancements to accomplish the Regional Goals and Measurable Objectives set forth in the IRWM Plan and facilitate application for grant funding to accomplish the enhancements; and
- Compile and, as necessary, submit data regarding planning and implementation efforts.

Carrying out these responsibilities falls on the RWMG Participants, as they are the formal governing body in charge of the IRWM Group that votes on and executes RWMG agenda items while representing the interests of the RWMG Participants, Stakeholders, and Interested Parties, including the DAC Workgroup. The members of the RWMG Participants are selected by each of the districts. There are no term limits for members of the RWMG, and the districts and agencies are responsible for the rules and practices governing their member selection. A ‘chairperson’ is selected by the RWMG Participants, via simple majority vote, as their representative to the IRWM Stakeholders and Interested Parties, as well as, the public and regional landowners.

The Semitropic WSD has served as the ‘Lead Agency’ insofar as noticing and hosting meetings; acting as Treasurer; and contracting with consultants for required services. Other classifications of IRWMP involvement include Stakeholders, or members that are directly involved with or potentially affected by the planning and management efforts of the RWMG; and Interested Parties, which are any private or public entities that have interest in the Region’s regional planning process but may or may not be directly involved. The objectives of the IRWM Plan are in favor of equal distribution of power and voice among Native American Tribes and Stakeholders irrespective of their financial contributions within the RWMG. Nevertheless, no Native American Tribal lands are located within the current Poso Creek IRWM Plan Area.

Note that all Interested Parties participate in the IRWM Group free of cost. The classifications cover those entities which have opted not to become a member or are legally precluded from becoming a member, but have provided a formal expression of interest in regional planning activities to the RWMG. Although the input from IRWMP Stakeholders and Interested Parties, besides the DAC Workgroup, are not weighted as ‘voting members’, these entities are still able to actively participate and invest resources in the planning process and are encouraged to do so. As such, these entities have provided a wide range of interests and information that add a great deal of diverse opinions and participation to the development and implementation of the IRWM Plan. An organization chart for the IRWM Group is shown below as Figure 2.1.

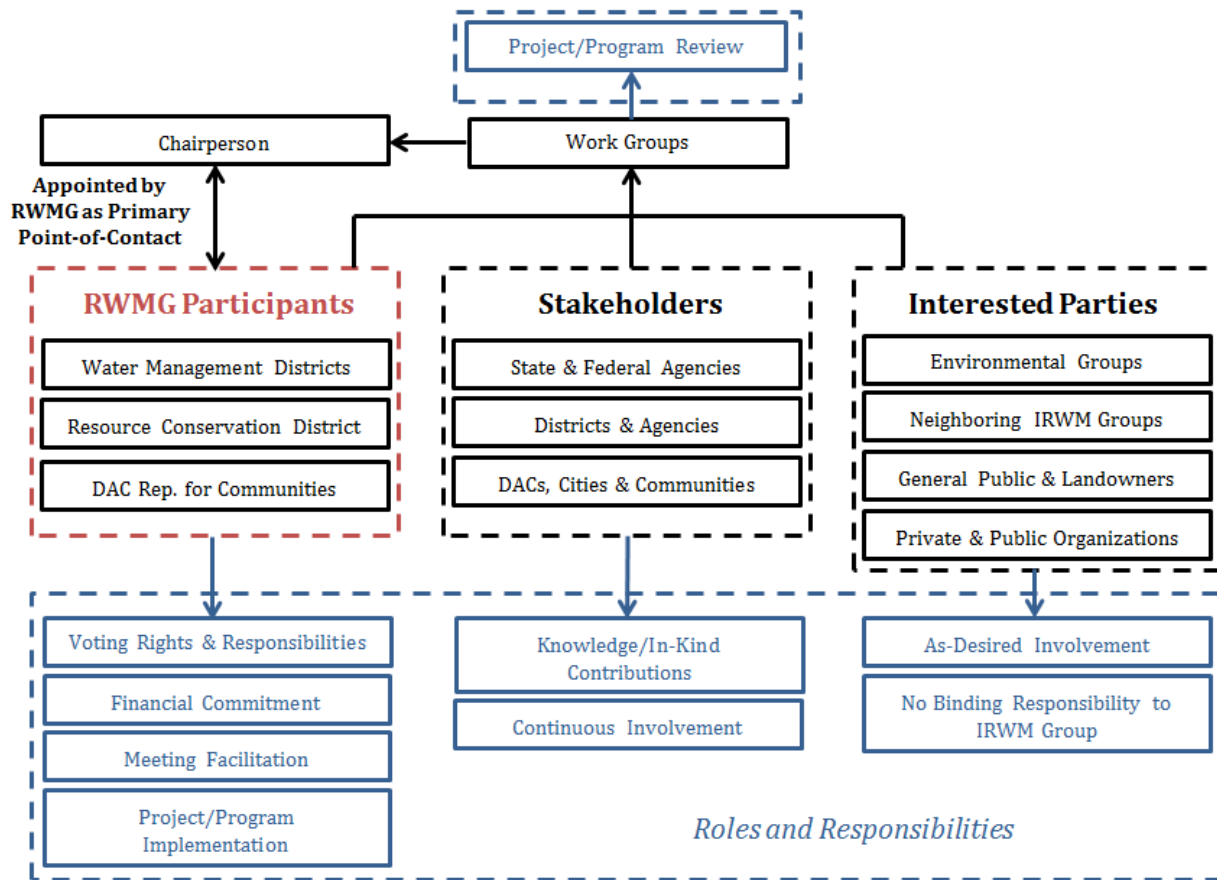

**Figure 2.1** Poso Creek IRWM Group Organization Chart

As shown in Figure 2.1, the RWMG may form various Work Groups to address specific projects, policy/program review, implementation, planning efforts, or specific regional tasks. Work Groups generally focus on a limited number of tasks where a broader member base may be advantageous to provide expertise or knowledge in a particular subject matter, such as a DAC-based project. There is a simple structure in place for the appointment of workgroups, meaning they are simply established by the RWMG on an as-needed basis. Members do not have to be associated with the RWMG Participants. Further description regarding regional Work Groups is covered in the following section.



## 2.3 Work Groups

The RWMG has overseen the formation of numerous work groups over time to assist the IRWM Group with matters involving governance; DAC planning efforts; IRWM Plan updating and maintenance of compliance; project and program development; technical issues, project and program implementation; budgetary issues; regional groundwater monitoring efforts; and other ad-hoc administrative efforts. As previously stated, the RWMG may assign an action item to a defined Work Group on an as-needed basis. Following is a brief list of some of the key Work Groups that have been involved in the IRWMP planning and implementation efforts (a more extensive list can be found in the other planning documents written by the RWMG since the original 2007 IRWM Plan, as listed in Table 10.1).

- *Budget Development*: Appointed Work Group that develops and manages the monetary resource budget for the Poso Creek RWMG.
- *Groundwater Banking, Transfer, and Exchange Efforts*: Appointed Work Group to coordinate with RWMG Participants who are active in groundwater recharge and banking efforts, as described in Section 3.4, and to address their concerns regarding project and program review.
- *Wildlife Enhancement*: Appointed Work Group to coordinate with environmentally-concerned Interested Parties and to address their concerns regarding project and program review.
- *IRWM Boundary Coordination with Neighboring IRWM Groups*: Appointed Work Group to discuss and resolve boundary concerns with neighboring IRWMs, as described in Section 3.11.
- *Development of Governance MOU*: Work Group that initiated, developed, and revised the MOU that governs the Poso Creek RWMG (Section 2.2).
- *DAC Work Group*: Appointed and long-standing Work Group to coordinate with and address the concerns of DACs within the Region, and to coordinate with the DAC Representative and other private and public DAC representation. DAC involvement in the IRWM Group is further described in Section 11.3.
- *Various Project and Program Work Groups*: Appointed and as-needed Work Groups to assess project and program feasibility and the potential impacts and benefits of implementation.

The public and regional landowners are encouraged to participate in the Work Groups based on their interests or stake in RWMG decisions. Some decisions may have direct effects to landowner water supplies or land use. As previously stated, all public involvement is classified as ‘Interested Party’ participation in the IRWM planning and implementation processes. Interested Parties need not be part of an entity or organization in order to participate, they can be any individual, whether a regional landowner or not, that attends an IRWM Group meeting, and they participate in the IRWM Group free of cost. None of the Interested Parties hold voting privileges

directly; however, they are encouraged to present concerns or suggest projects/programs to the RWMG at the noticed meetings of the RWMG.

If direct involvement in the IRWM Group is not possible or desired, the public is encouraged to contact the RWMG via e-mail, call, or through a letter. Contact for each of the RWMG Participants is listed in Appendix B. The RWMG desires to remain transparent with the public regarding decisions made, projects/programs considered, and development and adoption of IRWM Plan. The RWMG distributes formal communications, such as, Notice of Intent and RWMG Meeting Notices as required by California Government Code §6066, or when otherwise deemed appropriate by the RWMG.

## **2.4 Decision-Making Process**

The RWMG's modest size, coupled with its relatively simple governance structure (as illustrated in Figure 2.1), allows the group to easily assign an action item and reach a consensus decision in a quick and effective manner. Fundamentally, the process involves the discussion and review of the water management needs of RWMG Participants, Stakeholders, and Interested Parties regarding the Region at periodic, but formal, IRWM Group meetings.

IRWM Group meetings are usually held on the first Tuesday of each month at the office of the Lead Agency. If there are no action items up for consideration by the IRWM Group, then a monthly public noticed meeting may not be arranged. Conversely, if a higher-priority action item requires consideration, then a special meeting may be called with all RWMG Participants, Stakeholders, and Interested Parties adequately notified. At these meetings, an individual entity can present their project and program submissions to the IRWM Group under any classification and will be given a fair opportunity to participate in the planning process. If an action is needed that requires a decision by the RWMG at a special (implementation) meeting, it can happen quickly by introduction to the group by the Chairperson and a simple majority vote by the RWMG. If the action requires more time for discussion, and immediate action is not necessary, the vote can be tabled until a future meeting.

Action items are identified at each meeting and work groups are formed to accomplish assigned tasks, as needed. Examples of decisions by the RWMG that have been made efficiently and relatively quickly at the meetings include:

- Accepting recommended modifications to the Region boundary to conform with neighboring IRWM groups;
- Vetting and accepting structural (projects) and non-structural (programs) enhancements to accomplish the Regional Goals and Measurable Objectives set forth in the IRWM Plan
- Identifying and selecting projects to submit for Federal and State grant applications;

- Accepting revised or updated DAC projects into the Poso Creek IRWM Plan from external assistance, particularly from Self-Help Enterprises (SHE);
- Integrating wildlife enhancement components into the Poso Creek IRWM Plan based on recommendations from Tulare Basin Wildlife Partners and others, such as, the Kern National Wildlife Refuge;
- Approving cost-share agreements for financing RWMG activities related to implementing the Plan, making revisions to the Plan, and meeting DWR IRWM Planning Requirements,
- Discussing and approving RWMG Activities Budget and billing; and
- Approving and revising the MOU for Governance.

Note that the RWMG does not differentiate between major versus minor decisions based on expenses incurred or long-term impacts to associated Participants since the RWMG is not authorized to supersede individual district or agency management and planning efforts. As such, a simple majority vote is required to implement the activities or policies approved by the RWMG.

## **2.5 Plan Development**

As previously discussed in Sections 1.2 and 1.3, the IRWM Plan was developed by the IRWM Group, including the RWMG Participants, Stakeholders, and Interested Parties. The purpose of the regional, multi-district and agency, water management planning approach was to resolve and improve current or impending water resource issues by enhancing management practices.

The updated 2019 IRWM Plan was conceptualized and drafted by the IRWM Group and an external consulting firm (GEI Consultants, Inc., Bakersfield, CA). It is organized such that the sixteen IRWM Plan Standards, per the IRWMP Proposition 1 Guidelines, are fully addressed in a document that provides a clear description of regional conditions, resource management, and planning activities. The IRWMP Proposition 1 Guidelines, intending to improve regional water sustainability and to adapt to the effects of climate change on regional water supplies, were reviewed by the IRWM Group in a concerted effort to recognize and illustrate that the RWMG has evolved into a broader resource management planning focus in 2019 in comparison to the original 2007 IRWMP, with 2007 Planning Objectives.

As previously stated, the RWMG has maintained periodic meetings in a format that allows for adaptive management practices for updating the Plan in response to changing conditions to the Region both physically and in resource management. Section 5.1 covers the submittal and identification of projects and programs, with a similar process for identifying changes which may be made to the Plan when new topics and activities need to be addressed. In some cases, a working group comprised of any RWMG Participant, Stakeholder, or Interested Party may be assigned to a particular action item to aid in the review and planning process, at the discretion of the RWMG.

This process has provided flexibility during review and planning efforts for considering new topics and activities (updates) that need to be captured in the Plan.

The IRWM Group has established the goal of updating their IRWM Plan every 5 to 7 years, through associated Plan amendments or a complete re-write of the Plan, or as needed to satisfy new IRWMP standards established by the DWR. The RWMG may seek grant funds for updating the IRWMP, as they are made available. The IRWM Group also plans to document on-going planning and implementation efforts through annual reports that include a ‘Report Card’ providing a list of regional accomplishments (see Appendix A1 for the Report Card). Refer to Section 7.2 for details on Plan performance monitoring and the proposed annual reporting procedure.

## **2.6 Plan Adoption and Implementation**

The IRWM Plan and Plan Update were prepared and adopted following the public noticing procedure in accordance with California Government Code §6066. Appendix D contains copies of the public notices filed by the RWMG in (specified) local newspapers; specifically, the notice of intent to prepare and update an IRWMP and the notice of intent to adopt the updated Plan. Following public notice, the Plan is made available for public review and RWMG Participant, Stakeholder, and Interested Party consideration. Once applicable revisions, corrections, or suggested additions to the Plan are addressed, the Plan is formally adopted by each of the RWMG Participants. Appendix E contains a copy of the Resolution of Adoption forms filed by RWMG Participants. Note that any project or program proponents named in IRWM-specific grant applications that are not a RWMG Participant need to separately adopt the IRWM Plan prior to submittal of a funding application.

Recall that the IRWM Group was formed due to a regional concern regarding groundwater and surface water supply reliability, and the desire to address these concerns using a regional approach versus an individual approach through districts and agencies working together to ensure long-term suitability of water supplies in the context of a common groundwater basin. It is anticipated that this concern will continue to motivate the districts and agencies for many years into the future.

The governance structure of the RWMG also helps to ensure long-term implementation of the group, particularly implementation of the latest IRWM Plan. Recall that all RWMG Participants have signed the MOU outlining the governance structure of the RWMG (Section 2.1). In 2016, one of the original RWMG Stakeholders (Southern San Joaquin Municipal Utility District) requested to be added as a participant and voting member, made possible by a second amendment to the MOU. Participants can request removal from the MOU for various reasons, and thus the RWMG. However, the RWMG Participants’ signing of the document expresses the long-term interest and commitment to regional water management. By allowing the RWMG Participants, Stakeholders, and Interested Parties some flexibility to work together in the regional

planning and implementation processes, the IRWM Group has set up a governance structure (Figure 2.1) that ensures active participation and a sustainable organization.

To meet the financial obligations of the RWMG, and thus protect the long-term outlook of the group, the RWMG develops an annual budget for the year, which includes IRWM planning efforts and implementation described in the IRWM Plan. The annual budget is developed and approved at the beginning of each year, typically in January. Each RWMG member contributes their share of the projected annual budget in accordance with the cost-sharing provisions of the MOU; 50% of budget is split equally between the RWMG Participants, while the other 50% is split between the Participants based on the amount of acreage within each Participant's jurisdiction. The RWMG Participants are billed up to their shared limit, based on planning and implementation expenses, on an as-required basis. As part of the second amendment to the MOU, Southern San Joaquin Municipal Utility District (SSJMUD) agreed to reimburse the RWMG for expenditures not covered by grant funding and provided direct benefit to SSJMUD.

## **2.7 Coordination with Neighboring IRWM Efforts, State and Federal Agencies**

Interregional Coordination occurs through interaction of the RWMG Participants with other representatives of adjacent IRWM Regions to understand the specific water resources needs and priorities of the “overall region” within the Southern San Joaquin Valley, and Central Valley as a whole, explore common management and planning strategies, and consider regional projects and programs. In addition, State, Federal, and local agencies interact with the RWMG to foster and build relationships within the State, while maintaining a Stakeholder interest in the activities and policies of the IRWM Group. Note that while these agencies may have Stakeholder interest, their participation in the IRWM Group is different than other Stakeholders or Interested Parties since they administer grant support to accomplish the Regional Goals and Measurable Objectives of the IRWM Plan and maintain requirements to guide the regional planning process. Specific coordinating efforts between the Poso Creek IRWM Group and these agencies or neighboring IRWM efforts include:

- Meetings with neighboring established and developing IRWM groups within the Tulare Lake Hydrologic Region and Southern San Joaquin Valley. Participants in the meetings include representatives of the Kaweah Delta Water Conservation District, the Deer Creek and Tule River Authority, Kings River Conservation District, the Upper Kings IRWM, the Southern Sierra IRWM, the Kern County Water Agency, the Kern IRWM, and the Westside Drainage IRWM.
- Working with the Watershed Coordinators funded through the Tulare Basin Watershed Initiative within the Tulare Lake Hydrologic Region.

- Supporting the efforts of the ‘Partnership for the San Joaquin Valley’ (SJV Partnership) to develop an Action Plan that is a framework for planning for an eight-county area of the Central Valley.
- Formalizing letters of agreements with neighboring IRWMs, such as, formalized boundary agreement with Tule IRWM and Kern IRWM and participating as a Stakeholder in other IRWM planning efforts, such as, the Kern IRWM.
- Attendance at conferences including the USBR Mid-Pacific Conference, the California Association of Water Agencies, the California Irrigation Institute, and coordination meetings, such as, “Round Table of Regions” to understand regional projects and programs, discuss implementation of overall regional enhancements, and coordinate with other IRWM efforts.
- Participating in meetings with environmental entities, such as, the semi-annual Tulare Lake Basin Working Group meeting and working to develop and implement wildlife projects and programs in the Region.
- Presenting Plan project and program implementation case-studies at technical conferences, such as, the US Committee on Irrigation and Drainage (USCID) to share experiences of Poso Creek Regional planning efforts with other entities.
- Representation and participation in the Tulare Kern Funding Area IRWM Disadvantaged Community Involvement Program.

Note that maintaining governance structure, periodic updating to the IRWM Plan and active local participation for the implementation of the Plan by the Poso Creek IRWM Group provides other similar IRWM groups with a functional entity to communicate with for implementing water management strategies within the overall region. The RWMG will continue to engage regional water planning agencies and public entities through the IRWMP efforts.

### 3.0 Regional Description

In accordance with the IRWMP Proposition 1 Program Guidelines, this section addresses the ‘Region Description’ Plan Standard, which includes the requirements shown in the following table (along with identification of the specific subsection(s) where each requirement is addressed).

<b>Requirement</b>	<b>Plan Section(s)</b>
Explain how plan will help reduce dependence on the Delta supply regionally.	3.2
Describe watersheds and water systems.	3.5, 3.7, 3.8
Describe internal boundaries.	3.0, 3.5
Describe water supplies and demands for minimum 20-year planning horizon, including a description of potential effects of climate change.	3.1, 3.2, 3.3, 3.4
Describe current and future water quality conditions.	3.6
Describe social and cultural makeup.	3.0, 3.9, 3.10
Describe major water-related objectives and conflicts.	3.0
Explain determination of IRWM regional boundary and why region is appropriate for IRWM planning.	3.11
Describe neighboring and/or overlapping IRWM efforts.	3.11
Explain how opportunities are maximized for integration of water management activities.	3.11

As mentioned in Section 1.1, much of the land use in the Region consists of irrigated agriculture. The rich soils, climate, and irrigation water supplies have made it possible to grow a variety of crops, including almonds, grapes, citrus, pistachios, and vegetables. Agricultural production has been a significant part of the Region’s resource management for decades, with actively practiced, conjunctive management of surface water and groundwater supplies for irrigation. According to the 2016-2017 California Agricultural Statistics Review, Kern County is the state’s number one crop-producing county. In fact, Kern County would rank among the Top-20 states for crop values if it were its own state, based on 2016 USDA Economic Research Service (ERS) cash receipts. According to the Kern County Department of Agriculture and Measurement Standards’ 2016 Annual Crop Report (2017 Kern County DAMS), the gross value of all agricultural products in the county exceeded \$7.2 billion, which represents an increase of around 6% from the prior year (2015). Beyond crop sales, the economic benefits of a healthy agricultural industry include regional employment (approximately one agricultural job for every 38 cropped acres), a greater variety and availability of foods, and a stronger working class and regional economy.

Poso Creek is in a unique geologic region with a portion of the Region located within the Kern Fan and the north portion composed of thick clay layers that confine the upper and lower aquifers in some portions of the basin. These features explain the varying water level depths and

water quality characteristics. A major aquifer known as the forebay area (north end of the Kern Fan) is present throughout most of the area south of Seventh Standard Road and east of Wasco. This aquifer contains fine-grained strata and has not been assumed to act as a confining bed. In contrast, a large portion of SWSD north of Seventh Standard Road, a confining bed of about 300 feet in depth is present and contributes to significant differences in water levels. A Corcoran Clay layer is present to the northwest, closer to the Tulare Lake bed.

To maintain agricultural production in the Region at current levels, a long-term solution to water supply reliability must be developed and implemented. The Region's economy relies on supplemental water supplies from outside of the Region. Part of the solution to gain supply reliability, as outlined in this Plan, is found in local measures that require the cooperation and actions of the RWMG Participants, Stakeholders, and Interested Parties. These measures include both structural and non-structural projects/programs that are planned in cooperation with other entities in the State facing similar long-term water reliability issues. The consequences of failing to increase water supply reliability within the Region include, but are not limited to, increased costs of agricultural production; decreased cropped and irrigated acreage; decreased workforce; and significant economic losses, both locally and statewide.

While most of the water use is for agricultural purposes, there are some industrial (some of which are related to agriculture), commercial, and domestic users and communities in the Region that use water and typically rely on groundwater as the sole source of supply. The economic fiber of the Region depends on the effective, efficient, and conjunctive use of surface water supplies and groundwater from the common groundwater basin. The following sections include descriptions of water supplies and demands; watersheds and water systems; as well as the potential social, cultural, and economic impacts of regional resource planning and management.

### **3.1 Regional Water Supplies**

The Region relies on the conjunctive use of groundwater and surface water, where the latter includes local and imported supplies. The sources of surface water supplies were described and quantified in Chapter 4 of the 2007 IRWM Plan, which has been included herein for ease of reference as Appendix F1. Quantification included both the historical "baseline" (1981-2005) and the projected availability of surface water supplies going forward. The following table presents the average annual baseline amounts and the average annual projected availability from the 2007 IRWM Plan, as well as the 20-year average projections prepared for the 2014 Plan Update. The most recent projections for surface water availability are, at the time of the 2019 Plan Update, still being calculated in accordance with the Sustainable Groundwater Management Act. When these are finished and submitted by 2020, these quantities will be available in the corresponding GSP, and reflected in future IRWMP Updates.



**Table 3.1** Historical Baseline and Projected Availability of Surface Water Supplies

Source of Supply	Baseline (AF)	Projected Availability (AF)		
		2007 IRWM Plan <sup>1</sup>	2014 IRWM Plan Update	2019 IRWM Plan Update
Local	252,000	234,000	198,000	Pending
State (SWP)	213,000	149,000	123,000	Pending
Federal (CVP)	310,000	320,000	320,000	Pending
<b>Total</b>	<b>775,000</b>	<b>703,000</b>	<b>641,000</b>	<b>Pending</b>

<sup>1</sup> 2007 IRWM Plan projected availability of surface water supplies are covered in Appendix F.

It is noted that the historical baseline reflects the amount of water actually diverted into the Region; whereas, the two projections reflect the availability at the source of supply. Owing to mismatches between availability and demand, it is not practicable to utilize all of the available supply.

When water supply studies were being conducted in support of the 2007 IRWM Plan, there were few if any quantitative estimates of the potential impact of climate change on the availability of surface water supplies. Accordingly, the 2007 IRWM Plan did not reflect climate change. For the purpose of making a valid comparison with the projections in the 2007 IRWM Plan, this Plan’s amounts in Table 3.2 also reflect a future scenario without climate change. As shown in Table 3.1, the total of all surface water supplies projected to be available to the Region averaged 703,000 acre-feet annually in the 2007 IRWM Plan. This compares to a projected average of 641,000 acre-feet for the next 20 years, which implies a reduction of almost 9 percent in the projected availability of surface water supplies to the Region. This reduction is attributable to reductions in the projected reliability of SWP supplies and the projected availability of Kern River water supplies. As additional climate change data relevant to the Region becomes available, future IRWMP Updates (and the Region’s corresponding GSP documentation) will reflect it.

It is recalled that the 2007 IRWM Plan relied on the 2005 SWP Delivery Reliability Report for the purpose of projecting the availability of this source of supply. Beginning with the 2007 SWP Delivery Reliability Report, DWR reflected climate change in the water supply scenarios which were evaluated. Based on data contained in the 2017 SWP Delivery Capability Report, the following table presents a 20-year projection for two scenarios; one without climate change, and one with climate change.

**Table 3.2** Projected Availability of SWP Water with and without Climate Change

SWP Delivery Year	Conditions without anticipated Climate Change <sup>1</sup>		Conditions with anticipated Climate Change <sup>1</sup>	
	Table A %	Article 21 (1,000 AF)	Table A %	Article 21 (1,000 AF)
2017	62%	58	62%	58
2022	62%	58	61%	59
2027	62%	59	60%	60
2032	62%	60	59%	61
2037	62%	60	58%	62
20-Yr Avg.	62%	59	60%	60

\* Source: SWP Delivery Capability Report (2017).

<sup>1</sup> Anticipated climate change impacts are further explained in Section 13.0.

As shown above, the 20-year average “Table A” allocation is projected to decrease from 62 to 60 percent when climate change is considered. This implies a reduction of about 3.2 percent relative to the without-climate change scenario. In the absence of similar estimates for the other sources of supply, it is considered reasonable to apply this same reduction. Accordingly, it is estimated that climate change could further reduce the projected availability of all surface water supplies by about 20,000 acre-feet annually on average (3.2% x 641,000 acre-feet), which would result in a total projected amount of about 621,000 acre-feet annually on average. This is an average annual reduction of 82,000 acre-feet compared to the projected availability in the 2007 IRWM Plan (703,000 acre-feet minus 621,000 acre-feet). Relative to the 2007 IRWM Plan projection, this is a reduction of almost 12 percent, about one-quarter of which is attributable to consideration of climate change, with the remainder attributable to other factors. Finally, the projection for the next 20 years (from the most recent available data) is almost 20 percent less than the historical baseline.

### 3.2 Dependence on Supplemental Surface Water Supplies

As mentioned in Section 3.1 of the 2007 IRWM Plan, and the 2014 Update (see Appendix F), the Region’s principal supplemental surface water supplies include Kern River, CVP, and SWP water. The newly added member of the group, SSJMUD, also follows this pattern, obtaining all its surface water from CVP. The Region’s supplies are used in conjunction with groundwater to meet irrigation water requirements and to recharge the underlying groundwater. As previously mentioned, the districts were formed to provide public entities for entering into contracts for the delivery of supplemental surface water supplies. Consistent with their enabling legislation, these districts have been responsible for the delivery of supplemental water in their service areas. It is

noteworthy that these surface water supplies are the principal sources of water recharge in the Region and that all users beyond the RWMG, including the local communities, cities, and industrial entities, rely in whole or in part on the Region's groundwater. Since the 2014 IRWM Plan Update, the reliability of surface water supplies available to the Region has decreased. As a generalization, reliability is a measure of coincidence of supply and demand; the better the match, the more reliable or "firm" is the supply. The following are descriptions of the primary surface water supplies deliveries and used by the districts in the Region. They are further explained, in terms of watershed sources and delivery systems, in Section 3.5.

### *State Water Project (SWP)*

Kern County Water Agency (KCWA) holds the master contract with the State of California for the delivery of SWP water into Kern County. Accordingly, the SWP contractors in the Region (namely, Cawelo WD and Semitropic WSD) annually receive SWP water under contracts with KCWA. While each contract is for a specific amount of water, the amount available for delivery in any given year varies with hydrology and operational constraints on the SWP. Shortages in SWP supplies are occurring more frequently and are larger than originally envisioned, mainly due to regulatory restrictions on the pumping of water from the Delta. These restrictions have generally resulted from Court Orders and regulatory decisions related to endangered species, water quality, and environmental needs. Accordingly, SWP operations have been altered, which has resulted in reduced deliveries to contractors as well as some changes in the timing of deliveries.

It is also understood that the Delta must not only provide for external water users, but the internal water users and habitat needs within the Delta. Under this Plan, the districts within the Region will work cooperatively to reduce dependence on "firm" deliveries that originate from the Delta. To a large extent, this means leveraging the direct and in-lieu recharge assets and conveyance facilities of the Region to regulate water supplies from times of surplus or available pumping south of the Delta to times of need. This, in turn, translates to having the necessary conveyance infrastructure and management arrangements to wheel the available supplies to available absorptive capability and to recover and deliver previously-banked water during times of need.

### *Central Valley Project (CVP)*

The CVP contractors in the Region receive an allocation of available water supplies each year in proportion to the amounts set forth in their respective contracts with the federal government (USBR). Typically, there are two contract amounts; one for Class 1 water and one for Class 2 water. Class 1 water represents a "firm" allocation of supplies; however, there are years where only fractions of Class 1 water are delivered to regional users (in 2014 and 2015 districts experienced a zero allocation). Class 2 water is highly variable and principally occurs in wetter years.

Similar to the SWP, there are significant reliability concerns with the delivery of CVP water, as can be seen in Central Valley Project Water Plan 2014, released by USBR. Besides the continuation of dry hydrologic years, these concerns arise in part from plans to restore a portion of the San Joaquin River, which will reduce available supplies and impact the scheduling of available supplies. Similar to the Delta, the San Joaquin River provides a valued habitat for local flora and fauna that must be considered along with providing adequate water for contract water users. Under this Plan, the districts within the Region have the intent of working cooperatively to increase flexibility for delivery of water supplies that are competitive with uses in the San Joaquin River. In particular, this is being accomplished through projects and programs which increase the Region's ability to make the best use of water supplies when they are available and adding more efficient and effective conveyance infrastructure for delivering and storing available water supplies. The strategy is the same as that articulated for SWP water; namely, leverage the direct and in-lieu recharge assets and conveyance facilities of the Region to regulate water supplies from times of surplus to times of need. In summary, the goals and objectives are similar for all water contractors in the Region, regardless of whether the supplies originate from the SWP or CVP.

### *Kern River*

Excepting for the most senior rights, the Kern River has always been subject to large year-to-year fluctuations in yield depending on hydrology. For this reason, North Kern WSD constructed 1,500 acres of spreading ponds in the 1950s to help regulate its highly variable Kern River supplies. Kern River flows are regulated by Isabella Reservoir, which is located to the east of the Region in the southern Sierras. Conservation space available in Isabella Reservoir also helps to regulate Kern River supplies within a given year as well as from year to year.

The discharge of the Kern River depends on the accumulation of snowpack in the southern Sierras. Global warming (discussed in Section 13.1) has the potential to exacerbate the naturally high variability of this source of supply. In addition, dam safety concerns prompted USACE to impose storage restrictions on Isabella Reservoir in 2006 and these restrictions are not likely to be lifted until after 2020. Construction began on the reservoir in 2017 to raise the crest of both the main and auxiliary dams as well as improve the existing spillway and build a new emergency spillway. These safety modifications and improvements will help address the dam safety concerns and remove the storage restrictions but are not expected to be complete until 2022. In wetter years, these restrictions could result in the loss of Kern River water to the Region. In summary, while Kern River experience high variability as a reliable source of supply from year to year, completing the dam safety improvements does not exempt it from additional reliability concerns going forward.

### **3.3 Dependence on Groundwater Supplies**

Most of the Region overlies a usable groundwater basin; in particular, the Kern County Subbasin of the Tulare Lake Basin, which is part of the Central Valley aquifer system. DWR

Bulletin 118 (2003 Update) identifies the Kern County Subbasin as No. 5-22.14. The northeastern most portion of the Region overlies the Tule Subbasin, also part of the Tulare Lake Basin, and identified as No. 5-22.13 in DWR Bulletin 118. The 2016 Bulletin 118 Interim Update identified both of these regional subbasins as subject to critical conditions of overdraft. Both subbasins are shown in relation to the Region in Figure 1.4, and the sizes of the basins (as published by DWR) are indicated in Table 3.3 with quantities still valid for this 2019 Update. It is noted that these subbasins exist more for water accounting convenience than for any hydrogeologic considerations.

**Table 3.3 Groundwater Basins**

<b>Basin Name</b>	<b>Size (Sq. Mi)</b>	<b>Est. Capacity (AF)</b>	<b>Safe Yield (AFY)</b>
Kern County Groundwater Subbasin <sup>1</sup>	2,834	40,000,000	Unknown
Tule Groundwater Subbasin <sup>2</sup>	733	14,600,000	Unknown

<sup>1</sup> DWR San Joaquin District Kern County Groundwater Subbasin Information:  
[http://www.water.ca.gov/pubs/groundwater/bulletin\\_118/basindescriptions/5-22.14.pdf](http://www.water.ca.gov/pubs/groundwater/bulletin_118/basindescriptions/5-22.14.pdf)  
 - modified due to basin boundary modification creating the White Wolf Subbasin

<sup>2</sup> DWR San Joaquin District Tule Groundwater Subbasin Information:  
[http://www.water.ca.gov/pubs/groundwater/bulletin\\_118/basindescriptions/5-22.13.pdf](http://www.water.ca.gov/pubs/groundwater/bulletin_118/basindescriptions/5-22.13.pdf)

As previously mentioned, prior to formation of the agricultural water management districts, water for irrigation was obtained almost exclusively from groundwater sources, resulting in a rapid decline in static groundwater levels. The semi-arid climate in the Region, with little precipitation during a typical year (total precipitation generally around 5 – 9 inches), does little to offset water uses. Further, the Poso Creek and White River watersheds are the only local watersheds to naturally discharge into the Region, which is very infrequent and relatively small compared to total water uses in the Region. Accordingly, the Region is dependent on the conjunctive use of imported surface water supplies with the underlying groundwater reservoir.

To mitigate the impacts of groundwater use within the basin, districts were formed to provide the vehicle for entering into contracts for supplemental surface water supplies which were available from State, Federal, and/or local watershed sources. The use of supplemental surface water supplies in lieu of pumped groundwater has gone a long way to alleviate concerns regarding the stress placed on the groundwater basin; however, the Region has been experiencing shortages in the contract water supplies which have been caused by conveyance and/or pumping constraints in the Delta. These shortages have had the effect of increasing the stress on the groundwater basin. At present, all urban water demands in the Region are met exclusively with pumped groundwater; however, the total urban and environmental water uses have been estimated to be on the order of five percent of the total water use in the Region. Accordingly, urban water users feel the effects of the increased stress on the groundwater basin.

The groundwater level response to increased stress is captured by the extensive monitoring network, which includes both dedicated monitor wells and supply wells. “Continuously” recording water level sensors are installed in many monitoring wells in the Region. Long-term water-level data in selected wells are used to evaluate groundwater movement, storage conditions, and pumping lifts and costs. Those districts within the Region which registered as “monitoring entities” report groundwater level measurements from selected well locations to DWR’s California Statewide Groundwater Elevation Monitoring (CASGEM) program. Additional information on the collection of groundwater data and management by the RWMG Participants is presented in Section 7.6.

As of the time this 2019 update is being written, GSAs within the Poso Creek Region are still in the process of finalizing data and documentation for their Groundwater Sustainability Plans. When these are submitted to the state, they will have updated water supply and demand data which will be reflected in future IRWMP updates.

### **3.4 Regional Water Demands**

Water demands in the Region have been and will continue to be dominated by irrigated agriculture. Remaining demands principally include M&I and environmental. Historical water uses and projected water demands were addressed in Chapter 5 of the 2007 IRWM Plan, which has been included herein for ease of reference as Appendix F2. The trends enclosed in this appendix, including delivery patterns throughout the year, were valid for the 2014 Update and remain valid for this 2019 Update. Similarly, the baseline data provided in Appendix F2 remains sufficient in 2019 to observe patterns in regional water demands.

#### *Irrigated Agriculture*

The year-to-year fluctuations, as well as any trends, were evaluated in the 2007 IRWM Plan by compiling data regarding individual crop acreage and irrigated acreage from each of the water districts and irrigation districts in the Region. Collectively, these districts include on the order of 95 percent of the irrigated acreage within the Region. In other words, there is relatively little irrigated acreage that is not within an organized district as shown in Table 3.4. Over the historical “baseline” (1981-2005), the total irrigated acreage generally fluctuated between 340,000 and 375,000 acres, with an average of about 350,000 acres and no apparent long-term trend. Data from these same districts were compiled based on the most recent local water plans and yielded a total of about 363,000 irrigated acres (see below).

**Table 3.4 Irrigated Area in Poso Creek Region in 2018**

<b>District</b>	<b>Total Area (acres)</b>	<b>Irrigated Area (acres)<sup>1</sup></b>	<b>% of District Area</b>
Cawelo WD	44,700	33,600	75%
Delano-Earlimart ID	56,500	48,000	85%
Kern-Tulare WD	20,250	17,400	86%
North Kern WSD	60,000	52,900	88%
Semitropic WSD	221,400	136,000	61%
Shafter-Wasco ID	37,500	30,300	81%
Southern San Joaquin MUD	64,000	44,600	70%
<b>Total</b>	<b>504,350</b>	<b>362,800</b>	<b>72%</b>

While this total is a little higher than the average for the 25-year historical baseline, it is more importantly well within the year-to-year fluctuations which were seen in the historical baseline. Accordingly, based solely on irrigated acreage, there is nothing to suggest that the projected water demand for irrigated agriculture over the next 20 years will differ materially from the historical baseline. Water demands for irrigated agriculture are also a function of crop types or crop pattern. In this regard, noticeable trends exist in the time-series data. In particular, field crops have been decreasing over time in favor of nuts, primarily almonds and pistachios. This trend was observed over the historical baseline and the 2018 data indicates a continuation of this trend. This is illustrated in Table 3.5, which presents the crop pattern for 2005 (the last year of the historical baseline) and 2013.

**Table 3.5 Crop Pattern for Poso Creek Region**

<b>Crop Category<sup>2</sup></b>	<b>2005<sup>1</sup></b>	<b>2013<sup>1</sup></b>	<b>2014<sup>3</sup></b>	<b>Change</b>
Citrus and Subtropical*	9%	7%	6%	- 1%
Deciduous Fruits and Nuts*	37%	51%	47%	-4%
Field Crops	13%	5%	4%	- 1%
Grain and Hay Crops	14%	14%	11%	-3%
Truck, Nursery, and Berry Crops	5%	3%	5%	+2%
Vineyards*	22%	21%	27%	+6%
<b>Total</b>	<b>100%</b>	<b>100%</b>	<b>100%</b>	
<b>Permanent Crops</b>	<b>68%</b>	<b>78%</b>	<b>80%</b>	<b>+ 2%</b>

\* Permanent crops.

<sup>1</sup> Based on crop surveys conducted by each district in the Region.

<sup>2</sup> Percentages are based on the total for the crop categories shown in the table.

<sup>3</sup> Percentages are based on 2014 LandIQ data (most recent available data) for each district in Region, now including SSJMUD

Deciduous fruits and nuts (pistachios, almonds, apples, cherries, etc.) experienced the greatest decline in acreage, while vineyards have experienced the greatest increase. Citrus and subtropical fruits, field crops (mostly cotton), and grain and hay crops also experienced some decline. Relatively, almonds have a higher water demand than cotton or grapes, so the heightened emphasis on permanent vineyards is somewhat a reflection of water shortages. Accordingly, even though total irrigated acreage in the Region does not indicate any material change in the water demand for irrigated agriculture, changes in the crop pattern suggest an increase in demand over time. Further, this trend toward permanent crops represents a “hardening” of the total crop water requirement, which simply means that the demand must be met year in and year out, as compared to an annual crop where there is some choice to plant or not to plant in any given year depending on hydrologic conditions or other considerations.

This data is only a year more recent than that which was provided in the 2014 Plan Update, and thus the crop information provided in those district water management plans (which were also mentioned in the 2014 Plan Update) is still useful. According to these plans, the unit consumptive use of cotton is 2.78 AF/ac, while the unit consumptive use of almonds is about 3.39 AF/ac. To reflect the fact that not all almond acreage is at maturity at any given time, for illustrative purposes, it is assumed that the average consumptive use for all almond acreage is 95% of the use at maturity, or 3.22 AF/ac. Using this discounted unit value, converting one acre of cotton to one acre of almonds would result in an increase in the consumptive use of water for that one acre by about 16%. In terms of the total demand for the Region, this implies that a regional shift from 30% cotton and 40% almonds to 20% cotton and 50% almonds would result in an increase in the total consumptive use for the Region of 1.6%.

Table 3.5 indicates that “Deciduous Fruits and Nuts” went from 37% in 2005 to 51% in 2013 to 41% in 2014. For illustrative purposes, it is considered reasonable to estimate the impact of the larger 2005 to 2013 change by assuming that this involved the one-for-one conversion of cotton to almonds. This would imply an increase of a little more than 2% in the total consumptive use for the Region, which would also drop now that deciduous fruits and nuts have decreased in acreage by 2014. While not insignificant, this is a relatively small change in consumptive use compared to the decreases that have been evidenced in the surface water supplies available to the Region. Going forward, given the relatively significant percentage of the Region’s irrigated acreage that is already developed to permanent crops (about 80% in 2014; reference Table 3.5), it is projected that any increase in the total consumptive use for the Region as a result of a shift in crop pattern is likely to be relatively small over the next 20 years. In this regard, not only is the acreage which remains in annual crops limited, but the current drought conditions and the uncertainty that surrounds the Region’s surface water supplies is likely to adversely impact the trend that has been evidenced historically.



Finally, climate change has the potential to affect the use of water by agriculture through increased consumptive use and/or climate-induced changes in crop pattern. Section 13 includes more discussion in this regard.

### *Municipal and Industrial*

Collectively, the cities of Delano, McFarland, Shafter, and Wasco include the majority of the Region’s population. Three of these four cities have prepared UWMPs; Delano (2010), Shafter (2015), and Wasco (2010). The data from these most recent plans are used in Table 3.6, with Shafter’s 2015 data being the most recent data, and Delano and Wasco’s 2010 data being the most recent. Each of these plans includes a projection of gross water use at five-year time steps for the next 20 years (2015-2035). “Gross” simply means the total volume of water which is introduced into the water purveyor’s distribution system, keeping in mind that a portion of this amount makes its way to a wastewater treatment plant and is available for reuse, and some amount becomes deep percolation from landscape irrigation. Based on population data for 2016, the combined service area population for these three cities is about 70% of the Region’s total population. Accordingly, the projections for the three cities were combined for a given projection year and divided by 70% to provide a projection for the Region, all of which are summarized in Table 3.6.

**Table 3.6** Actual (2010 or 2015) and Projected Gross Use of Water for M&I Purposes

<b>Year</b>	<b>Shafter (AF)<sup>1</sup></b>	<b>Delano (AF)<sup>2</sup></b>	<b>Wasco (AF)<sup>3</sup></b>	<b>Total (AF)</b>	<b>Poso Creek Region (AF)<sup>4</sup></b>
2010	4,738 <sup>5</sup>	9,272	4,681	18,691	27,000
2015	4,260	10,666	6,661	22,363	32,000
2020	4,702	11,786	8,925	25,774	37,000
2025	5,193	13,023	11,469	29,662	43,000
2030	5,733	14,391	14,293	34,392	49,000
2035	6,328	15,902	17,397	39,601	57,000

<sup>1</sup> Data taken from Table 15 of 2015 Shafter UWMP, unless otherwise indicated.

<sup>2</sup> Data taken from Table 3-13 of 2010 Delano UWMP, see Section 10.1.

<sup>3</sup> Data taken from Table 4-4 of 2010 Wasco UWMP, see Section 10.1.

<sup>4</sup> Projection for the Poso Creek Region, as described in the text.

<sup>5</sup> Data taken from Tables 12 through 14 of 2010 Shafter UWMP, see Section 10.1.

The regional projections imply a 20-year average gross use of about 44,000 acre-feet. However, based on population estimates since 2010, it is anticipated (and seen, in the case of Shafter) that the 2015 UWMPs will reflect lower projected water use as compared to the 2010 UWMPs. Based on the projections which are currently available, the net use of water for M&I purposes over the next 20 years is expected to average on the order of one-half of the gross use, or about 22,000 acre-feet annually. It is noteworthy that any additional urban development would

likely remove a comparable amount of irrigated agriculture, which would simply trade one demand for another, with little measurable change in total demand over the 20-year planning horizon.

Finally, it is noted that the 2007 IRWM Plan included an estimate of the gross regional use of water for M&I purposes of 40,000 acre-feet annually under 2006 conditions. This stands in contrast to the 2010 estimate of 27,000 acre-feet (reference Table 3.5). The difference is explained by an error in the source data which was used for the 2007 IRWM Plan. Use of the 2010 UWMPs for this Plan, as noted in Section 10.1, highlighted this error.

### *Environmental*

As discussed in the 2007 IRWM Plan (reference Appendix F2), there are two dedicated environmental and recreational uses of water in the Region; the Kern National Wildlife Refuge, and a number of “duck clubs”. There is nothing to suggest that these uses will change or that any new uses will be developed. Accordingly, no changes are projected over the 20-year planning horizon.

Over the next 20 years, agricultural water use is not expected to change significantly from current levels. If there is an increase, it is expected to be relatively small and would be the result of a shift to crops that use more water and/or climate change. M&I water use is expected to increase, and the projections in Table 3.6 indicates that the increase could be on the order of 75% to 80% of 2015 levels; however, it is anticipated that this will be reduced when the latest UWMPs are available. Further, any increase in urban development will likely be at the expense of existing agricultural development. Accordingly, any increase in urban demand would be substantially if not entirely offset by a decrease in agricultural demand. Finally, no changes are expected in the environmental and recreational water uses in the Region over the next 20 years.

## **3.5 Watersheds and Water Systems**

There are two watersheds that naturally discharge to the Region; Poso Creek (the Region’s namesake) and White River. While these streams discharge to the Region, their watersheds are largely located outside of the Region. In particular, the Poso Creek watershed is located within the Kern IRWM Region, and the White River watershed is located within the Southern Sierra IRWM Region. While these watersheds are outside of any direct management by the Poso Creek RWMG, they are in the category of matters which require coordination with adjoining IRWM regions. Both are ephemeral streams that make relatively small contributions to the Region’s water supplies. The Region’s principal sources of surface water supplies are all diverted into the Region; namely, Kern River, CVP, and SWP water supplies. The watersheds for these sources of supply are located well outside the Region and range from the northern Sierras to the southern Sierras. Accordingly, there is considerable infrastructure involved in providing for the diversion and delivery of these sources of supply into the Region, as shown in Figure 1.2.

Prior to formation of the agricultural water management districts within the Region, water for irrigation was obtained almost exclusively from groundwater sources, resulting in a rapid decline in static groundwater levels. To mitigate this decline “special districts” were formed under the provisions of Division 13 of the Water Code for the purpose of obtaining a “supplemental or partial water supply” for irrigation. District boundaries, or the extent of individual service areas and governing areas described in Section 2.1, reflect the group(s) of landowners or agricultural water users that came together at the time that each district was formed for the purpose of addressing water supply issues in their area. Each of these districts entered into contracts for surface water supplies which were developed external to the Region to supplement the pumping of groundwater within the Region for irrigation. Brief descriptions of these districts are provided in Appendix C. Since their formation, the districts in the Region have become uniquely positioned with assets, both natural and man-made, that collectively enable *regional* solutions to the individual district challenges of balancing surface water and groundwater supplies through an integrated water planning approach.

### *State Water Project (SWP)*

The SWP provides the most distant source of supplemental water delivered into the Region. This supply originates in the northern Sierras and is ultimately pumped from the Sacramento-San Joaquin River Delta and conveyed south in the California Aqueduct along the west side of the San Joaquin Valley. Similar to the Friant-Kern Canal, the Aqueduct is lined with concrete. Two of the districts in the Region are long-term SWP contractors; Cawelo WD and Semitropic WSD. Semitropic WSD diverts water from the Aqueduct into the Region through three turnouts, which collectively provide significant diversion capacity and individually provide a certain degree of flexibility and redundancy to water diversion and delivery operations. DWR operates and maintains the SWP facilities, including the turnouts from the Aqueduct. Direct delivery of SWP water to Cawelo WD requires that water be diverted from the Aqueduct into the Cross-Valley Canal (CVC) near Tupman. Through a series of pumping plants, water is lifted east in the CVC to Bakersfield, where one final pumping plant is necessary to lift the water into the Beardsley Canal for conveyance to Cawelo WD. The CVC is operated and maintained by the Kern County Water Agency.

### *Central Valley Project (CVP)*

The Friant Division of the CVP provides most of the CVP water delivered into the Region. Three of the districts within the Region are long-term CVP-Friant contractors; Delano-Earlimart ID, Shafter-Wasco ID, and Southern San Joaquin MUD. The San Joaquin River watershed is the source of supply for the Friant Division and these long-term contractors. The US Bureau of Reclamation (USBR) regulates this source of supply in Millerton Reservoir which is formed by Friant Dam on the San Joaquin River. Like the Kern River, though located further north, the San Joaquin River has its origins high in the Sierras. The Friant-Kern Canal is a major concrete-lined facility which conveys San Joaquin River water south from Millerton Reservoir to its terminus at

the Kern River near the City of Bakersfield. As the canal makes its way along the east side of the San Joaquin Valley, it slices through the east half of the Region. Accordingly, diversions of CVP-Friant water into the Region are made at several turnouts which are located along the Friant-Kern Canal. In addition to the turnouts which serve the long-term contractors, North Kern WSD and Cawelo WD have constructed two turnouts to provide for the diversion of wet-year supplies on an as-available basis to augment groundwater recharge within the Region. The canal is operated and maintained by the Friant Water Authority, which is a joint-powers agency comprised of the long-term Friant contractors, including the three located within the Region.

### *Kern River*

Fed by snowmelt runoff from the southern Sierras, extending as far north as Mount Whitney, the Kern River is the most southerly of the significant Sierra watersheds. The Kern River discharges to the San Joaquin Valley near the City of Bakersfield. Until the mid-1950s, the flow of the Kern River was unregulated or unimpaired. With construction of Isabella Dam and Reservoir in the mid-1950s by the US Army Corps of Engineers (USACE), most of the flow of Kern River has been regulated. At spillway crest, the reservoir has a capacity of about 568,000 acre-feet. Though constructed with the primary purpose of flood control, other benefits include conservation and recreation. Operations at Isabella Dam are managed by USACE.

North Kern WSD secured its rights to divert Kern River water into the Region in the early 1950s. In the mid-1970s, North Kern entered into a long-term contract for the diversion and use of additional Kern River water. At that same time, Cawelo WD and Kern-Tulare WD also entered into similar long-term contracts. The direct diversion of Kern River water into the Region takes place at two primary points of diversion which coincide with the headworks of the Beardsley Canal and the Calloway Canal, respectively. Diversions are by gravity and North Kern is responsible for the operation of these two main conveyance canals. During “normal” operations, the Beardsley Canal is used before the Calloway is used owing to the fact that diversions are at a higher elevation than the Calloway and thereby have more utility with regard to gravity distribution. Further, the Beardsley Canal is concrete-lined, whereas the Calloway is mostly unlined, thereby maximizing the delivery of the diverted water into the Region. Once in the Region, the Beardsley Canal changes name (to the Lerdo Canal) and is unlined. Accordingly, the Calloway Canal is typically relegated to use only during wetter years when the capacity of the Beardsley Canal is exceeded.

### *Water Conveyance Infrastructure (Irrigation Distribution Systems)*

From the previously-described points of diversion from the Kern River, the Friant-Kern Canal, and the California Aqueduct, each district with a supplemental surface water supply has constructed additional main conveyance facilities and/or distribution laterals to deliver the water to individual growers within the district. While the main conveyance facilities typically rely on canals owing to the required capacity, a combination of canals and pipelines are used for laterals which divert water from the main conveyance facilities. The irrigation distribution system for a

given district includes all those facilities necessary to divert water at the source of supply and make deliveries to each of the farm turnouts within a given service area. Each farm turnout “typically” serves about 160 acres and all deliveries are measured. While all these facilities are operated and maintained by each of the special districts in the Region, the on-farm distribution of water is the responsibility of each individual grower. In addition to canals and/or pipelines, other irrigation distribution system features include pumping stations and small regulating reservoirs. These systems are more particularly described in each district’s Agricultural Water Management Plan, Water Conservation Plan, and/or Groundwater Management Plan. A general layout of the distribution networks and water conveyance infrastructure is shown in Figure 3.1.

### *Conveyance Interconnections*

Irrigation distribution systems have been designed and constructed to deliver water to a specific service area. Over time, in order to increase operations flexibility and redundancy; to facilitate water exchanges; to respond to changed or changing conditions; and generally improve water management, a number of inter-district connections have been constructed. These are connections between the irrigation distribution systems of two individual districts which allow water to be moved from one system to the other, often in either direction. In addition, connections have been constructed between the main conveyance facilities of the regionally significant sources of supply. All of these are referred to hereinafter as “interconnections”.

Connecting the Region’s principal sources of supply began in the 1970s, with construction of the CVC. The CVC provides a connection between the Aqueduct on the west side of the Valley and the Beardsley Canal on the east side of the Valley. It also set the stage for the subsequent construction of an interconnection between the CVC and the Friant-Kern Canal and an interconnection between the CVC and the Calloway Canal. It is noteworthy that the latter interconnection was identified in the 2007 IRWM Plan as a proposed project and its construction has since been completed. The CVC, in combination with these three interconnections, provides the plumbing necessary to move water between all three of the Region’s sources of supplemental surface water supplies; Kern River, CVP-Friant, and SWP. Though typically smaller in scale, several interconnections between the irrigation distribution systems of two adjacent districts have been constructed which also allow water from the different sources of supply to be moved around within the Region to some extent to be moved from one system to the other. Once again, some of these interconnections were identified in the 2007 IRWM Plan as proposed projects and have since been constructed.

### *Minor Streams*

As previously noted, Poso Creek and White River constitute a relatively small and infrequent source of water supplies to the Region, much of it as recharge from channel seepage. Dry much of the time, the stream channels provide east-west movement corridors for wildlife, as well as some riparian habitat. In addition, the channels have been used to convey and/or recharge water released from the Friant-Kern Canal from time to time, primarily during very wet periods.

The channels are maintained to some extent to provide carrying capacity for flood control purposes. In the past, USACE has conducted studies regarding the feasibility of constructing a dam and reservoir on Poso Creek; however, this proposal has yet to prove feasible.

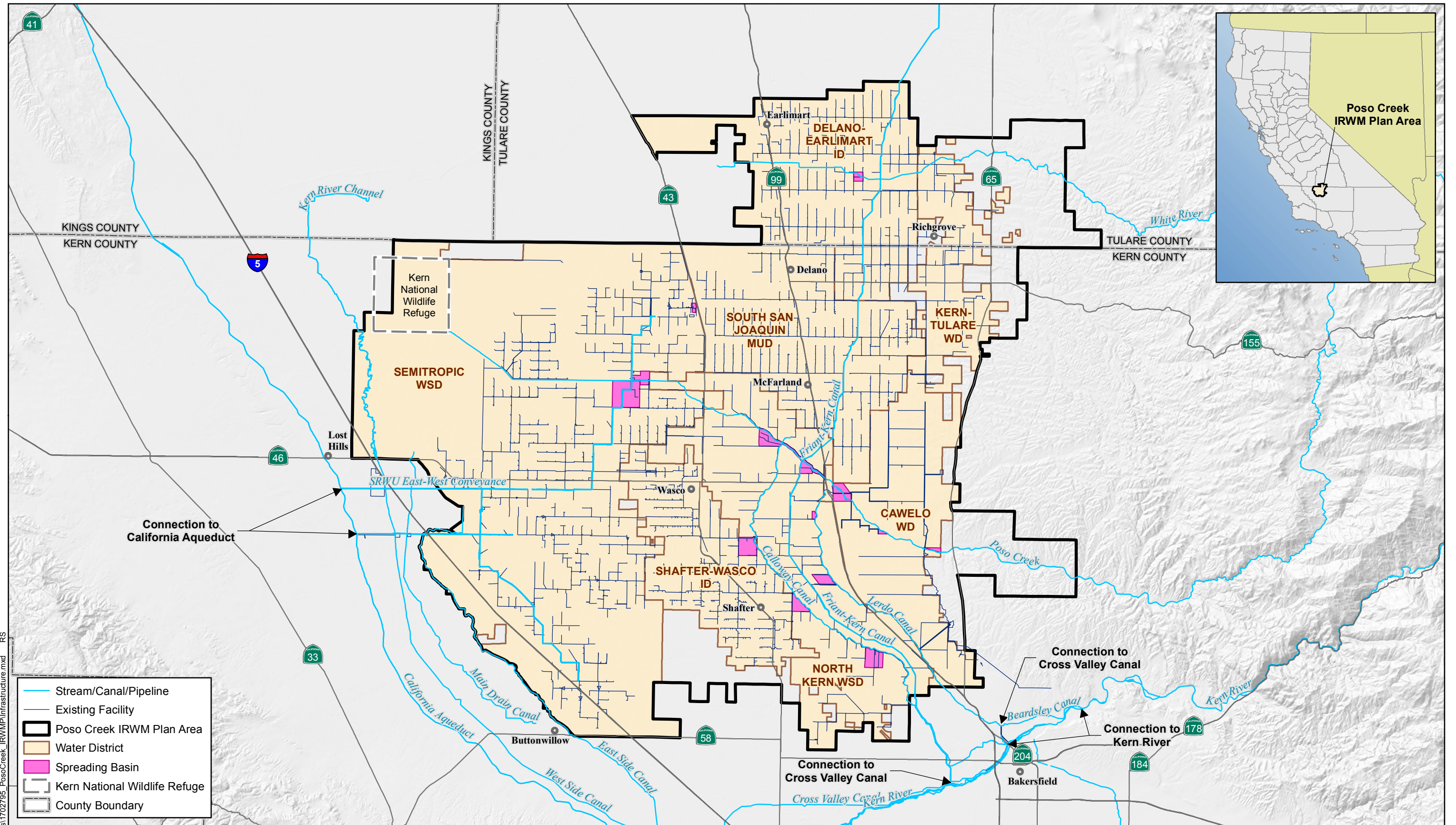

29-May-2019 Z:\Projects\1702795\_PosoCreek\_IRWMP\Infrastructure.mxd RS

2019 Integrated Regional Water Management Plan (IRWMP) Update  
Kern and Tulare Counties, California

Poso Creek IRWM Group



WATER DISTRIBUTION NETWORK  
AND CONVEYANCE INFRASTRUCTURE

JUNE 2019

FIGURE 3.1

## *Groundwater Recharge*

The Region overlies a large hydraulically-connected groundwater basin which has been used conjunctively with available surface water supplies for decades. Conjunctive management is intended to preserve the underlying basin and to mitigate groundwater level declines. Groundwater recharge within the Region occurs intentionally through the use of constructed spreading ponds and stream channels (Poso Creek and White River). It also occurs incidentally, through the use of unlined canals and as deep percolation of applied irrigation water. These are both forms of direct recharge. In addition, indirect recharge refers to the delivery of surface water supplies in lieu of pumped groundwater to satisfy irrigation water requirements. To the extent that the available surface water supplies are regulated, this is the preferred approach; however, to the extent that the surface water supplies are available in excess of then current irrigation demands and the water cannot otherwise be regulated, then direct recharge through spreading ponds is necessary in order to capture the water.

With several thousand acres of constructed spreading ponds, the Region has significant capability to recharge otherwise unregulated water supplies that are available from time to time and are in excess of the irrigation demand at the time that the supplies are available. About one-half of this acreage was developed more than 50 years ago to regulate highly variable Kern River supplies; however, the remaining half has been developed in more recent times to cope with the reduced reliability of available surface water supplies. Dedicated spreading ponds now exist in Semitropic WSD, North Kern WSD, Cawelo WD, Shafter-Wasco ID, Southern San Joaquin MUD, and Delano-Earlimart ID. While the spreading ponds are maintained by the districts within which they are located, they are very much a regional asset, with benefits accruing to the common groundwater basin which underlies the Region. In combination with significant dewatered storage capacity and conveyance connections to three independent sources of surface water supplies, these spreading assets are a very significant feature of the Region's conjunctive management of available water supplies. In this regard, a 400-cfs pumping plant and discharge pipeline were constructed since formulation of the IRWM Plan to link some of the existing spreading ponds with other sources of supply and to generally increase the rate at which water can be diverted and delivered to spreading, thereby maximizing the utility of the existing ponds and the use of available surface water supplies. Lands which have been developed to spreading are typically comprised of several ponds or cells which are created and separated by contour dikes, as illustrated in Figure 3.2.





**Figure 3.2** Constructed Spreading Ponds for Groundwater Recharge (Semitropic WSD).

### *Groundwater Recovery*

In general, groundwater use in the Region relies in the use of deep wells that are owned and operated by growers to meet on-farm water requirements; however, some of the districts have developed district-owned and operated deep wells. In particular, North Kern WSD, Cawelo WD, and Semitropic WSD have each developed deep well pumping capability, with Shafter-Wasco ID currently constructing wells. These are the same districts where most of the constructed spreading ponds are located. While privately-owned on-farm wells have limited geographic utility, district-owned wells typically discharge into the district's distribution system, where the utility is increased significantly. In addition, in the case where a given well exhibits elevated TDS (for example), this provides a means of blending that water in the district's distribution system (under the right conditions), thereby rendering the well useable and meeting irrigation water requirements. Figure 3.3 shows a typical district-owned deep well discharging into a district canal.



**Figure 3.3** Typical Groundwater Well Discharging to a Main Conveyance Canal.

It is worth noting that Semitropic WSD, Cawelo WD, and North Kern WSD operate long-term “Water Banking Programs” that allows neighboring districts and/or “banking partners”, including districts outside of the Region, to store surplus water in a district and to recover their water when needed. These districts receive surface water from the banking partners in years of ample supplies and deliver it to their landowners for irrigation use in lieu of groundwater pumping. Groundwater which otherwise would have been pumped remains in storage, credited to the account of the banking partner. In times of water supply deficiencies, the water may be recovered and returned to the banking partner either through physical deliveries (i.e. water returned to the California Aqueduct) or by an exchange by delivery of surface water supplies to the banking partner while pumping groundwater from district and landowner wells.

Other prominent groundwater banking facilities in Kern County include the Kern Water Bank and the Pioneer Project, which are out-of-Region facilities managed by the Kern Water Bank Authority and KCWA, respectively. Located directly south of the Region on the Kern River fan, and still within the Kern County Subbasin, both are direct recharge-based water banking projects. To the extent that water is available to the Region which cannot be absorbed within the Region, these water banking projects provide an additional storage facility for otherwise potentially lost surplus surface water supplies available during very wet periods. Further explanations of these Groundwater Banking Projects, as well as regional groundwater recharge efforts and groundwater recovery (well pumping), are provided in the Groundwater Management Plans, AWMPs, and WCPs of the individual districts within the Region (see Section 10.1).

### *Other Water Supplies*

While urban wastewater remains fairly limited in the Region, water which is brought to the surface in the process of producing oil has become a measurable source of water. Further, unlike wastewater, this represents new water. Within the Region, most of this water is generated in the so-called Kern River Field. Owing to its proximity to the Kern River Field, most of this water is delivered through a pipeline to Cawelo WD. In recent years, deliveries have ranged from about 25,000 to 30,000 acre-feet annually. Kern-Tulare WD and North Kern WD also receive amounts of oilfield produced water.

### **3.6 Water Quality Conditions**

The Region's principal sources of supplemental surface water include State, Federal, and local supplies, all of which are used conjunctively with the underlying groundwater. In addition to water quality monitoring conducted by the project operators, such as the SWP and the CVP, each district in the Region does some sampling and testing of its surface water supplies as well as produced groundwater. Since the districts in the Region provide water for irrigated agricultural uses, testing is typically limited to constituents that have relevance to the water's suitability for crop irrigation (reference Section 7.6), and this applies to both surface water sources and groundwater. On the other hand, the cities and communities in the Region rely exclusively on pumped groundwater and their sampling and testing is focused on suitability for potable uses.

The predominant constituents of concern with varying levels between the shallow and deeper groundwaters are Total Dissolved Solids (TDS), nitrate, and arsenic. Varying constituent levels are more prominent in areas where a confining bed is present. Higher salinity, nitrate, arsenic and uranium are found in the shallow groundwater where the Corcoran clay and adjacent thick confining layers are present. The middle aquifer tends to contain lower concentrations of these constituents. Contaminant concentrations increase again in the deep aquifer, generally below 800-feet.

#### *Surface Water Quality*

Since the use of supplemental surface water within the Region is solely for irrigation use, this discussion is focused on that use. Generally speaking, the quality of Kern River, SWP, and Friant-CVP water is considered good to excellent in terms of suitability for irrigation and agricultural use. The quality of SWP water supplies is regularly monitored by DWR at several locations along the Aqueduct, many of which are located 'upstream' of the delivery points into the Region (reference Figure 3.1). The USBR also conducts water quality monitoring along the Friant-Kern Canal, which also includes locations upstream of delivery points into the Region. Friant-CVP water and Kern River water exhibit the lowest concentrations of total dissolved solids (TDS), generally on the order of 50 mg/L and 100 mg/L, respectively. The TDS concentration in SWP water is higher, typically ranging from 250 mg/L to 350 mg/L.

In addition to the principal sources of supplemental surface water, Poso Creek and oilfield-produced water also make contributions to the Region's water supplies. Poso Creek exhibits TDS concentrations that are typically higher than the Kern River, but less than SWP water. The oilfield-produced water is monitored for certain constituents with regard to its suitability for crop irrigation, principally the concentrations of boron and TDS in the context of salt-sensitive crops. Oilfield-produced water is typically blended with other water sources to reduce the concentration of salts to an acceptable level for the crops to which it is applied. For example, the TDS concentration of oilfield-produced water ranges up to 700 mg/L; however, after blending, the quality is typically no more than 450 mg/L, which is satisfactory for most agricultural uses. Additional information regarding the use of this unique source of supply, and conformance with the CVRWQCB's waste discharge requirements, are covered in district-specific Agricultural Water Management Plans (reference Section 10.1).

Irrigation concentrates the salts that are in the irrigation water, and the importation of supplemental surface water supplies brings more salts into the Region. Accordingly, without any natural outflow, the salt load continues to increase within the San Joaquin Valley, which includes the Poso Creek Region. These observations were acknowledged when the RWQCB's Basin Plan was prepared for the Tulare Lake Basin. While there are no anticipated changes in surface water quality going forward, a long-term increase in the concentration of salts in groundwater can be expected.

### *Groundwater Quality*

#### **Irrigated Lands:**

The main production zones are generally of good water quality and suitable for irrigation (often ranging from 250 to 350 mg/L); however, there are areas of poorer quality groundwater found within the Region which are either not used for irrigation or are blended with other supplies to achieve acceptable levels of TDS. In these areas, concentrations of TDS and chlorides have exceeded the limits normally desired for irrigation of salt-sensitive crops, 450 mg/L and 140 mg/L, respectively. Shallow groundwater is present in those areas where the underlying sediments result in the occurrence of shallow groundwater, and it is typically marked by high salinity. Depending on location, this can be the result of natural conditions and/or irrigation practices.

Criteria set by DWR define three classes of groundwater according to TDS: Class 1 (TDS < 700 mg/L), Class 2 (700 mg/L < TDS < 2000 mg/L), and Class 3 (TDS > 2000 mg/L), where Class 1 is the best quality. Most of the historical water quality sampling in the Region has been done for agricultural purposes by the individual districts. Based on this sampling, groundwater underlying the Region generally meets the Class 1 criteria as noted above; however, there are exceptions. In general, groundwater in the western parts of the Region is of relatively poorer

quality and has higher TDS content relative to the eastern part of the Region. The prevention of groundwater migration from the poor-quality areas to the higher quality areas is an obvious management goal of the RWMG. Groundwater moves in response to a gradient; accordingly, it is critical to bring in supplemental water supplies into the Region to maintain groundwater levels or mitigate long-term groundwater level declines.

None of the districts in the Region provide any regional sub-surface drainage facilities, nor do they control or monitor any on-farm subsurface drainage systems. Accordingly, the RWMG does not have measurements of water quality with regards to agricultural runoff and drainage to the extent that it exists within the Region. However, the RWMG Participants do participate in and help facilitate the Irrigated Lands Regulatory Program (ILRP) in cooperation with the KCWA and Kern River Watershed Coalition Authority. The individual districts control the results of these monitoring efforts and ensure that all water quality is suitable for irrigation if within the district's conveyance network.

Finally, for reasons discussed in the immediately preceding section (Surface Water Quality), a long-term increase in the concentration of salts in groundwater can be expected going forward, which is the principal concern for irrigated agriculture. With that said, the long-term effect of implementation of the RWQCB's recent General Order regarding agricultural discharges to groundwater remains to be seen, particularly as it relates to nitrate concentrations in groundwater, which is a concern with regard to potable uses. Districts in this region are able to plan efforts to manage their salinity and nitrate levels with the help of programs like the Central Valley Salinity Alternatives for Long-Term Sustainability initiative (CV-SALTS). CV-SALTS, started in 2006, is a collaborative effort to find solutions to the salt problem in the Central Valley and adopt long-term solutions that will lead to enhanced water quality and economic sustainability. The studies which this group undertakes can be used by members of the Poso Creek IRWM Group to better understand the nature of their salinity issues and the options available to offset them.

### **Evaluation of Public Water Systems:**

In accordance with the IRWMP Proposition 1 Program Guidelines, this section addresses the requirements from Assembly Bill 1249 that requires a description of location, extent, impacts, and necessary actions for the following contaminants: nitrate, arsenic, perchlorate, and hexavalent chromium.

In 2017, a groundwater assessment of the Poso Creek IRWM region was conducted by evaluating groundwater data from public water systems, engaging regulators from the State Water Resources Control Board's Division of Drinking Water (DDW), and identifying all public water systems in Human Right to Water portal. DDW's Drinking Water Watch database was used to evaluate the groundwater results collected for the eleven public water systems within the region. In addition, an evaluation on the water quality characteristics of the Poso Creek region was

gathered from a biennial report prepared by Schmidt<sup>1</sup> (biennial report). Data presented in the Report is primarily from sampling conducted by the Kern Fan Monitoring Committee between February and October 2013 but also discusses data trends dating back to the first biennial report for 1995-1996.

Characterizing the water quality of the groundwater in the Poso Creek IRWM region satisfies a requirement within the 2019 Plan Update and more specifically addresses Assembly Bill 1249 (AB 1249) which states that “if the IRWM region has areas of nitrate, arsenic, perchlorate, or hexavalent chromium contamination, the Plan must include a description of location, extent, and impacts of the contamination; actions undertaken to address the contamination, and a description of any additional actions needed to address the contamination” (Water Code §10541.(e)(14)). Each public water system’s water quality data was evaluated to determine the water quality issues within their respective water system. To confirm with the general water quality issues in the IRWM region, the data was also compared to the biennial report.

Findings from this evaluation show that the most common water quality issues within the Poso Creek IRWM region are: total dissolved solids (TDS), nitrate, arsenic, hexavalent chromium, dibromochloropropane (DBCP), 1,2,3-trichloropropane (TCP) and small area pockets of uranium. Perchlorate was addressed per AB 1249 and is not an issue within this region. Salinity issues characterized by TDS have historically been a problem in this groundwater basin. As defined in the biennial report, the data evaluation also indicates that salinity levels increase towards the west portion of the region due to the base of fresh water becoming shallower. Some of the water systems have wells with nitrate at half the maximum contaminant level (MCL) with an increasing trend. This similar situation occurs for arsenic as well. Hexavalent chromium is more prevalent in the central and northern portion of the region. Uranium occurs in small pockets throughout the region, with only one water system, Buttonwillow Community Water District, having a well over the MCL. DBCP is primarily detected in the central region of the IRWM area with some wells showing an increasing trend. The new state drinking water standard for TCP compliance began on January 1, 2018. DDW has indicated that TCP is more prevalent in Kern County based on previous groundwater data. Once public water systems start conducting the required initial monitoring in 2018, it is a possibility that all the water systems within the region have TCP detected in their groundwater wells.

All public water systems within the IRWM region are currently in compliance with federal and state drinking water standards, except for Rodriguez Labor Camp for nitrate exceedances. There are plans in place for Rodriguez Labor Camp to consolidate with Richgrove Community Services District. For water systems that have constituents exceeding the drinking water standards,

---

<sup>1</sup> Quadrennial Groundwater Monitoring Report for the Semitropic Water Storage District Water Banking Project (2011-2014) dated May 2017

there is treatment in place. However, given that most of these public water systems are in disadvantaged communities, assistance may be needed to install treatment in the future if more wells show an increasing trend and exceeds a current or future drinking water standard.

The following subsections discuss the common constituents of concern for the Poso IRWM region. A review of DDW's Drinking Water Watch, the Schmidt Report, and correspondences with DDW were used in the following discussion for water quality constituents commonly found within Poso. The water quality discussion is divided by constituent and explains the drinking water standard for each along with how the water quality data for the 11 State regulated water systems compare to the biennial Report.

### Total Dissolved Solids (TDS)

TDS is a constituent that serves as an indicator of groundwater salinity. Based on drinking water standards, the recommended secondary maximum contaminant level (SMCL) of 500 parts per million (ppm) and upper limit of 1,000 ppm is used to evaluate water quality data discussed in this chapter. SMCLs are set for aesthetic concerns that are not known to cause immediate public health issues. Components of TDS tend to be naturally occurring and enter groundwater through runoff or leaching from natural deposits.

As defined in the biennial report, there are several areas with TDS levels above the drinking water upper acceptance limit of 1,500 ppm: these levels are typically found either in the shallow groundwater west of Interstate 5, and in wells that extend near the base of fresh water. Another area is primarily beneath the City of Wasco. As previously described, geology of this region is believed to contribute to these high TDS levels. Because of these conditions, there is little groundwater pumping in this area.

Deeper groundwater is not thoroughly characterized because there is not enough information due to the lack of deep groundwater wells. Samples from the available deep wells show levels below 500 ppm in most of SWSD, except along the southwest part of SWSD from about Merced Ave to Seventh Standard Road. Even lower TDS levels below 200 ppm, is in a large area northwest of Wasco, near Wasco, and in the eastern part of North Kern WSD. Variability in TDS levels of the deep groundwater is consistent with the geologic contours that define the base of fresh water. USGS reports that the base of fresh water is shallow and less well-defined towards the west side of the Kern Subbasin and fairly deep towards the south and east ends of the basin.

In the western portion of the Poso Creek region, TDS levels are higher. Buttonwillow Community Water District is located in the southwestern region and has one of two active wells with TDS levels over the SMCL and showing an increasing trend. The other well has fluctuating levels but the average is currently below half the SMCL. Lost Hills Utility District's well field is located about 12 miles east of Lost Hills within SWSD. There are two active wells in this water system and both show an increasing trend. Both wells have average concentrations slightly above

half the SMCL, while one well has detections above half the SMCL. Sample results from these wells are consistent with the Report showing that there are higher TDS levels in the south west portion of the Poso Creek region.

In the central portion of the region, the TDS levels are generally below the SMCL. Pond Mutual Water Company and Pond School Water system are located in the north portion and the City of Wasco and the City of Shafter water systems are located in the southern portion. Pond Mutual Water Company only has one well and TDS levels are showing a slight decreasing trend with average results below half the SMCL. Pond School Water System also has one well with average TDS results less than half the SMCL. City of Wasco TDS results are steady and average results are less than 200 ppm. However, TDS concentrations for the City of Shafter show an increasing trend. There are three wells with average results greater than half the SMCL to the SMCL.

TDS is not much of a concern in the northern portion of the Poso Creek region. Water quality data collected from the public water systems located in this area justifies this. Rodriguez Labor Camp shows a decreasing trend and the average result is below the SMCL. Earlimart Public Utility District has five wells with stable TDS concentrations all below half the SMCL. City of Delano also does not have an issue with TDS. The TDS levels in the 15 wells are mainly below the SMCL.

The evaluation of the TDS data from the public water systems confirms the findings in the biennial report. TDS is generally higher, mainly above the SMCL, in the shallow groundwater and below the SMCL in the deeper groundwater. In addition, the higher TDS levels are located more along the western border of the Poso Creek region.

### Nitrate

Nitrate as nitrate has a primary maximum contaminant level (MCL) of 45 ppm. Effective January 1, 2016, nitrate is no longer reported to DDW as nitrate. Nitrate for drinking water standards in California is now being reported as nitrogen with a MCL of 10 ppm. Nitrate is an acute contaminant meaning that it can cause immediate health issues when it is consumed over the MCL. Infants below the age of six months who drink water with nitrate over the MCL may quickly become seriously ill if not treated right away. High nitrate levels interfere with the capacity of an infant's blood to carry oxygen, commonly known as Blue Baby Syndrome. Symptoms include shortness of breath and blueness of the skin. A similar phenomenon may also occur in pregnant women. Nitrate tends to come from runoff and leaching from fertilizer use, leaching from septic tanks, and sewage, or erosion of natural deposits.

According to nitrate data collected for the biennial report, small pocket areas with nitrate levels from half the MCL to over the nitrate MCL are located to the west and southwest areas from the city of Wasco. There is also a small pocket in North Kern WSD between Calloway and Lerdo



Canals. Nitrate concentrations were non-detect in the western portion of Poso Creek region in SWSD. Nitrate results from the public water systems within Poso Creek region were evaluated to confirm the findings in the biennial report. Buttonwillow Community Water District does not have a concern with nitrate and it coincides with the study area from the report indicating that the western portion shows non-detectable nitrate levels.

In the central region, the report indicated small pockets of areas with high nitrates. The City of Wasco has some wells with nitrate concentrations greater than half the MCL (5 ppm). There is one groundwater well that shows an increasing nitrate trend. The average result of that well is 9 ppm. If nitrate levels continue to increase, the city of Wasco will need to mitigate nitrate to continue using this well. This coincides with the report since it stated nitrate concentrations around half the MCL was detected west of Wasco and concentrations close to or exceeding the MCL east of Wasco. Tricia Wathen, Senior Sanitary Engineer with DDW, advised that Wasco has seasonal wells that are offline during the colder months due to demand. When the wells come online after a seasonal shutdown, they need to be flushed to waste for at least a couple days for the nitrate levels to drop and stabilize prior to pumping into the distribution system. It is unclear from just reviewing the database if samples were being collected to maintain compliance with monitoring requirements with minimal flushing or if they were flushed to waste for a longer period prior to being put into the distribution system. The City of Wasco has plans to install two online nitrate analyzers by mid-2018 (Wathen, personal communication, November 3, 2017).

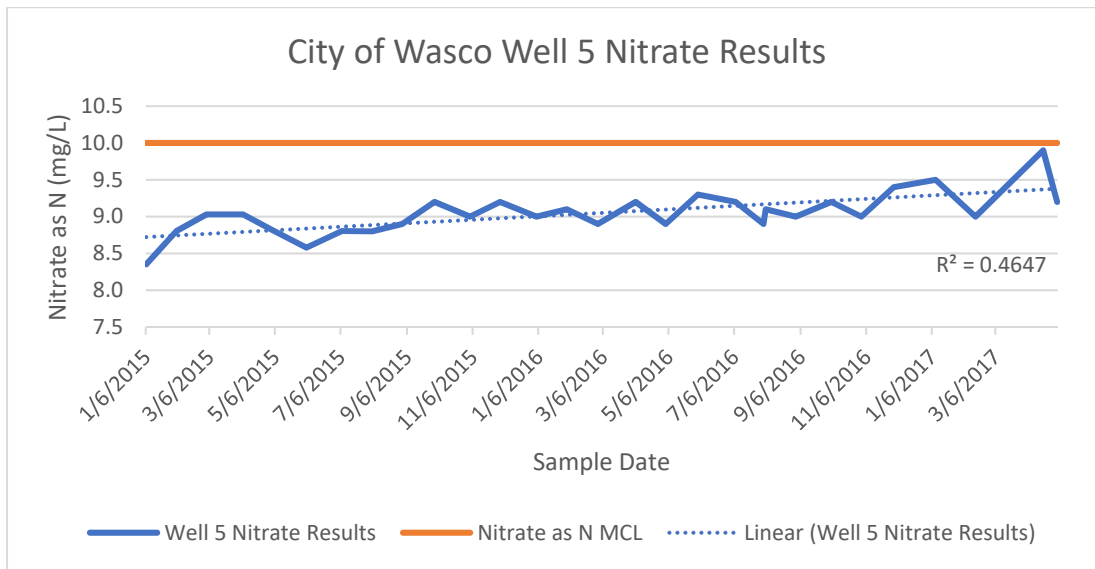

The City of Shafter is also located centrally in the region and has five of seven wells with an increasing nitrate trend. Of those five wells, two of them have recent nitrate results over the MCL of 10 ppm. The average nitrate results of these five wells are also over half the MCL. According to the report, there are higher nitrate concentrations north of Shafter and slightly southwest of Shafter.

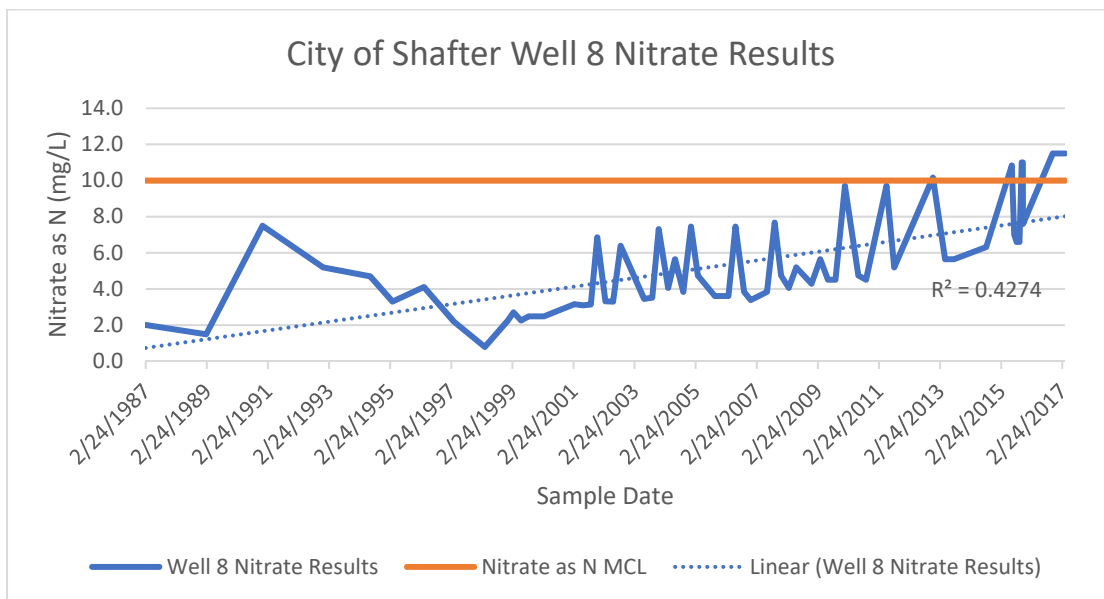
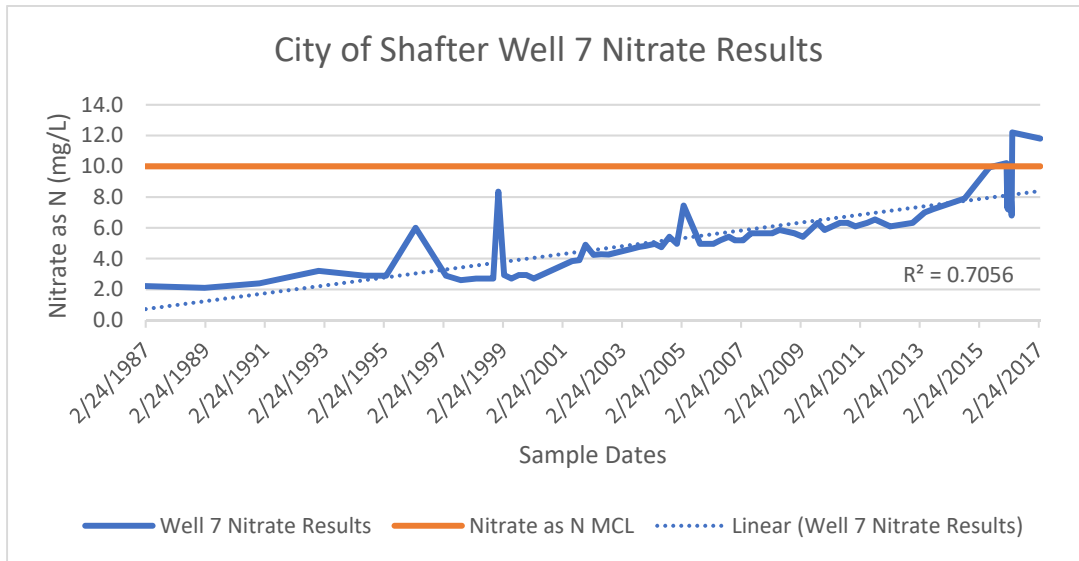

Pond Mutual Water Company and Pond School Water system, which are also located centrally each have low levels of nitrate detected. Pond Mutual Water Company has a slight increasing trend; however, results are still below half the MCL. Pond School has a stable trend with results below half the MCL. City of McFarland is also centrally located, and it has one of two wells that shows an increasing nitrate trend, with the latest result greater than half the MCL. The average is almost at half the MCL.

There was no nitrate data in the biennial report for the northern portion of Poso Creek region. Nitrate is generally not an issue for Earlimart Public Utility District, which is the northern most water system, except for one well. Out of the five wells, the newest well drilled in 2016 has

nitrate concentrations above half the MCL with an average concentration at 6 ppm. All the other wells have nitrate detections below half the MCL.

The area just south of Earlimart Public Utility District has water systems with nitrate contamination. Rodriguez Labor Camp has nitrate concentrations over the MCL. To mitigate this, Rodriguez Labor Camp has installed Point-of-Use (POU) systems as an interim measure. As a long-term measure, Rodriguez Labor Camp will be connected with Richgrove Community Services District and the planning for this effort has already been completed. Richgrove Community Services District has one of two wells with nitrate levels fluctuating and sometimes fluctuates over the MCL. City of Delano has one well with nitrate levels over the MCL and an increasing trend. From discussions with DDW, City of Delano installed a Biotta biological treatment plant with DWR grant funding. A conditional use permit has been issued. Six of the 15 wells have nitrate levels greater than half the MCL with increasing trends.

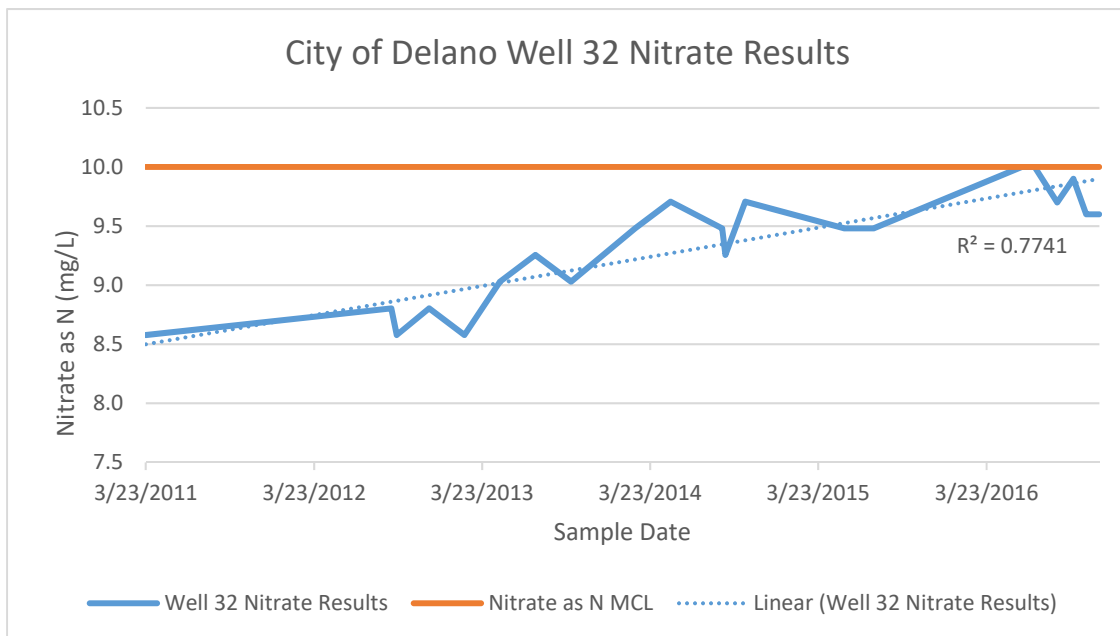

For the water systems that have average nitrate results greater than half the MCL with increasing trends, they will need to monitor their wells closely. With an increasing trend, it is likely that the well will eventually exceed the nitrate MCL and will be out of compliance in the near future. It would be best for the water systems to start planning for treatment or other alternatives to meeting the nitrate MCL especially when results are near 80% of the MCL. Nitrate is an acute contaminant and exceeding the MCL would require public notification and customers would not be allowed to drink the water until nitrate levels drop below the MCL or treatment is added.

### Arsenic

Arsenic is a chronic contaminant, meaning that consumption of the constituent over many years may cause health effects. Most arsenic in Kern County is derived from natural geochemical

processes – erosion of natural deposits leaching into groundwater over time. When water is consumed for many years with arsenic levels over the MCL, some people may experience skin damage or circulatory system problems and may also have an increased risk of getting cancer. Arsenic has a primary MCL of 10 parts per billion (ppb).

In the biennial report, sampling was conducted from both supply and monitoring wells. Sampling results followed in line with other previous reports of the region indicating that arsenic concentrations tend to increase towards the old Tulare Lake bed. Results also indicated that higher arsenic concentrations were seen in the deeper groundwater where the 300-foot clay layer is present. High arsenic levels over the MCL is noted in a similar area of SWSD where high TDS levels are noted. Another area within SWSD with arsenic levels over the MCL is in the northeastern portion of the district near the borders of Southern San Joaquin MUD, North Kern WSD, and Shafter-Wasco ID.

An evaluation of the arsenic water quality results available on DDW's database agrees with the biennial report. Arsenic concentrations are higher in the western portion of the region. Lost Hills Utility District has two wells with arsenic levels over the MCL. The water system is treating for arsenic by blending the two wells together prior to arsenic treatment. Due to the retirement of a seasoned operator and a new treatment operator unaware of routine maintenance on the pH probe, there were some effluent results that were over the MCL. Since this incident, the treatment plant has been producing water that meets the arsenic standard. The average effluent result is about half the MCL. Buttonwillow Community Water District has one of two wells with arsenic levels greater than half the MCL. However, there is a decreasing trend for this well. The other well has average arsenic levels at half the MCL also with a decreasing trend.

There was no data available in the biennial report for the central region for comparison to the public water systems. A review of the arsenic results in DDW's database indicates arsenic being prevalent and an issue in the central portion of the Poso Creek region. Four of seven City of Shafter's wells show an increasing arsenic trend. These same wells have average arsenic concentrations greater than half the MCL. Pond Mutual Water Company also has fluctuating arsenic levels all over the MCL in their only well. Point-of-Use (POU) treatment units have been recently installed in June 2017 and the water system is in compliance.

Pond School Water System has arsenic levels over the MCL with a slight increasing trend in their only well. The average arsenic result on the well is 17 ppb. Arsenic treatment was installed on this well in 2011. However, since treatment has been installed, there have been ten arsenic results over the MCL. The most recent effluent result in May 2016 was at 14 ppb, which is over the MCL. From discussions with DDW, it was noted that the pH adjustment on the chemical pump began working intermittently in September 2016. This caused the pH to be unchanged at times from its raw source of approximately 10 units. With the pH not adjusting properly, this undermined the arsenic treatment process resulting in high iron and arsenic levels in the effluent. In addition to the pH issue, the backwash flow meter was not functioning properly, therefore backwashes on the

filters were not being performed. Since these issues have been resolved, Pond School Water System has been in compliance with arsenic.

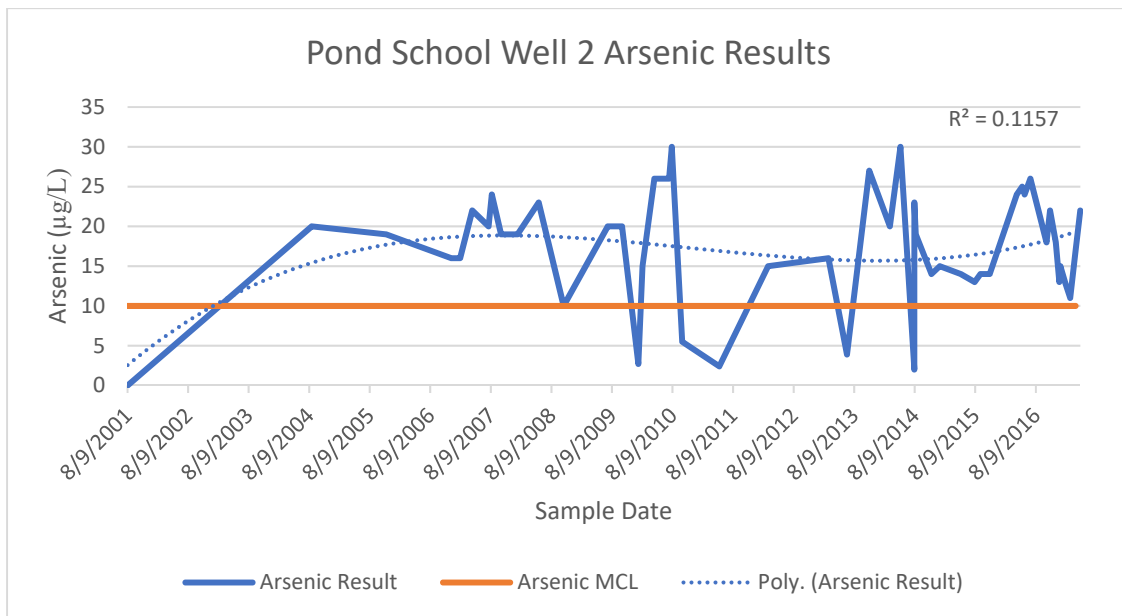

The City of McFarland has two wells that both contain arsenic concentrations. Both wells have a decreasing trend with one well having arsenic consistently at the MCL, while the other well has levels around half the MCL.

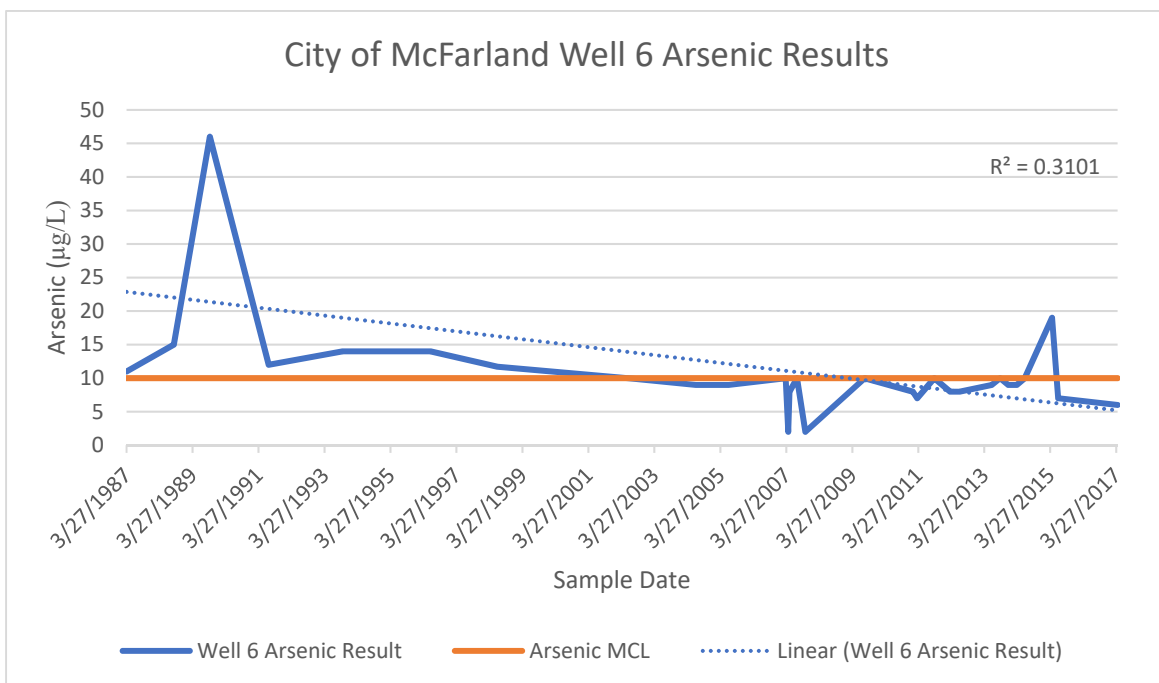

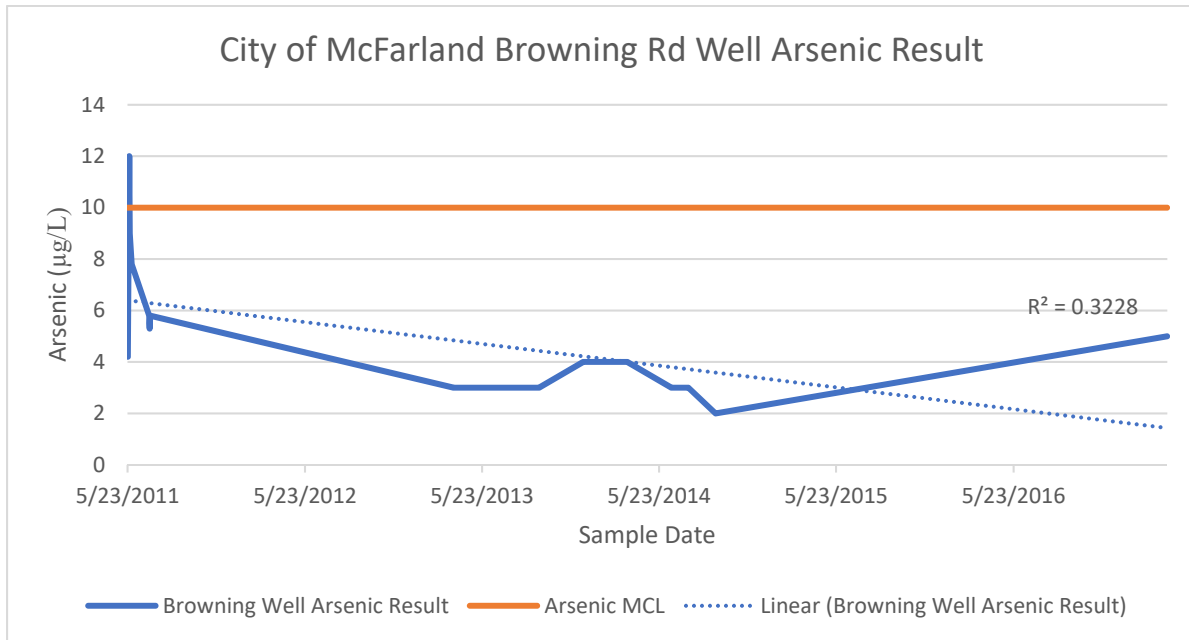

In the northern part of the region, there is a pocket of wells that have arsenic problems. Earlimart Public Utility District is the northernmost water system and has arsenic around half to less than half the MCL. For the most part, the arsenic trends are stable. However, just slightly south of Earlimart, two water systems: Richgrove and the City of Delano have arsenic issues. Richgrove has one of two wells with arsenic results at the MCL. The average of the results is slightly over the MCL at 11 ppm. The City of Delano has 10 of their 15 wells with arsenic levels at either half or greater than the MCL, with most showing an increasing trend. Arsenic treatment has been installed on four wells. The other remaining six wells that currently doesn't have treatment will need to be monitored closely. If the Running Annual Average (RAA) for four quarters is over the arsenic MCL, then treatment will be required by DDW.

Arsenic is an issue that spans a majority of the Poso Creek region. As a measure to meet compliance, the water systems have installed POU's or well head treatment. However, even with a treatment plant, a system may still exceed arsenic on the treated/effluent side if there is not proper operator training. One of the challenges in the rural and disadvantaged community is the lack of highly, skilled, and trained operators. This will remain a challenge not just for Poso Creek region but for any regions with disadvantaged communities.

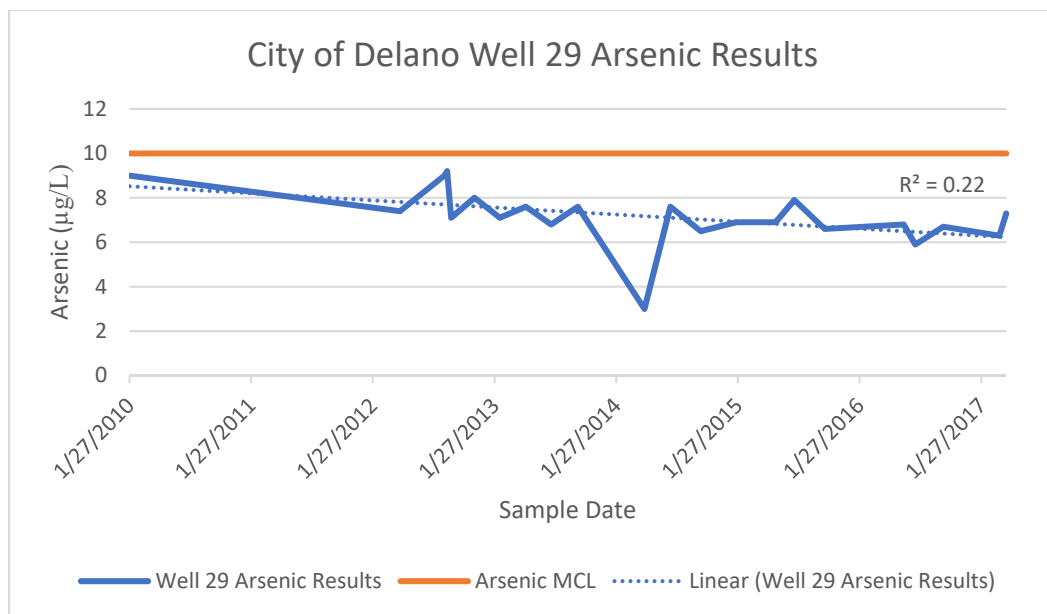
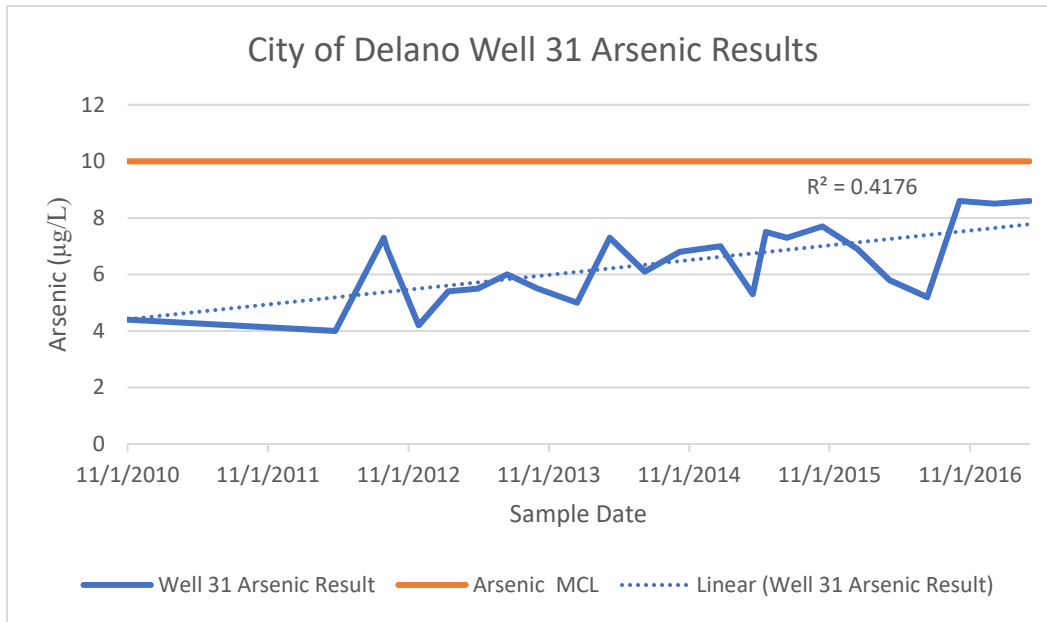

## Perchlorate

Perchlorate is an acute contaminant with a state primary MCL of 6 ppm. There is currently no federal MCL for perchlorate. Perchlorate is an inorganic chemical used in solid rocket propellant, fireworks, explosives, flares, matches, and a variety of industries. It tends to enter drinking water because of environmental contamination from historic aerospace or other industrial operations that used or use, store, or dispose of perchlorate and its salts. Perchlorate has been shown to interfere with uptake of iodine by the thyroid gland. This reduces the production of thyroid hormones, leading to adverse effects associated with inadequate hormone levels. The function of thyroid hormones is necessary for prenatal growth and development of the fetus as well

as normal growth and development for the infant and child. In adults, the thyroid hormone is necessary for normal metabolism and mental function.

From the review of water quality from the public water systems within the Poso Creek region, perchlorate is not a constituent of concern. Most of the perchlorate results were non-detect. In addition, the biennial report does not mention perchlorate.

### Hexavalent Chromium

There is no federal MCL for hexavalent chromium. California adopted the hexavalent chromium MCL of 10 ppb in July 2014. However, on May 31, 2017, the Superior Court of Sacramento County invalidated the MCL. In a press release dated August 1, 2017, DDW adopted a resolution to remove the MCL and will no longer enforce compliance plans that public water systems entered into agreement for hexavalent chromium. Water systems that had planned or already completed the installation of hexavalent chromium treatment are encouraged to continue operation of these facilities. DDW will begin the process for adopting the new MCL and it may be at the same level as the invalid one of 10 ppb.

Hexavalent chromium is a chronic contaminant and tends to come from discharge from electroplating factories, leather tanneries, wood preservation, chemical synthesis, refractory production, and textile manufacturing facilities. It may also be naturally occurring and come from erosion of natural deposits. When water is consumed for many years with high hexavalent chromium levels, some people may have an increased risk of getting cancer.

Hexavalent chromium samples that were collected from February to October 2013 for the biennial report showed areas that exceed for hexavalent chromium are generally in the same area where arsenic was also exceeded. Sampling was mainly conducted in SWSD area. A review of the public water systems hexavalent chromium results outside the SWSD area were evaluated.

The areas that have hexavalent chromium issues are more in the central and north areas. For the northernmost water system, Earlimart Public Utility District has all five of their wells with hexavalent chromium levels above 5 ppm with average results around 8 ppm. Two wells show a steady trend, while two other wells show fluctuating levels. The newest well shows an increasing trend with the average at 5 ppm. The City of Delano, located just south of Earlimart, has two of their 15 wells with levels at or greater than 10 ppb. There are five wells that have hexavalent chromium greater than 5 ppb. Most of the public water system wells have only one result. In the central region, the City of McFarland has one of two wells that has hexavalent chromium results slightly above 5 ppm while the City of Wasco has two of five wells that has hexavalent chromium levels at 5 ppm. Other areas in the region do not show issues with hexavalent chromium.



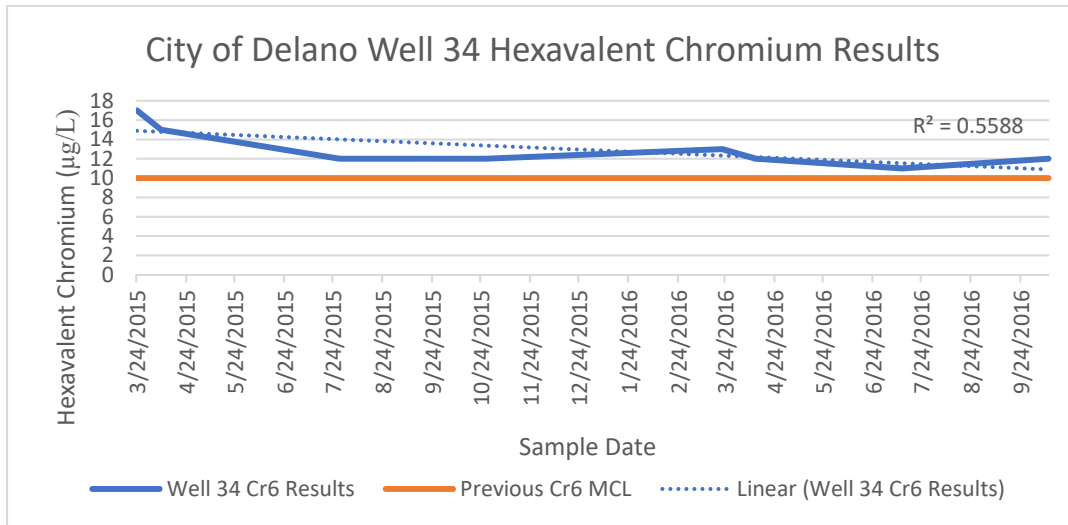

### Uranium

Uranium is a chronic contaminant with a primary MCL of 20 picocuries per liter. Uranium tends to be naturally occurring from erosion of natural deposits. Consuming water with uranium over the MCL over many years may cause kidney problems and can also lead to an increased risk of getting cancer.

Uranium does not seem to be a widespread issue in the Poso Creek region. For most of the SWSD region, uranium levels were less than 5 picocuries per liter. There are small pockets of areas where uranium is over the MCL. One area is in the northwestern portion of SWSD, west of Central Valley Highway. Other small pockets are located west of the cities of Wasco and Shafter. A slightly larger area with levels over the MCL is similar to the area where arsenic and hexavalent chromium are also over the MCL on the southwestern portion of SWSD near the Main Drain Canal.

From the water systems that were evaluated, only one well within Buttonwillow Community Water District has uranium concentrations over the MCL with an increasing trend. This well went into standby status in 2016 since it was not in operation for more than five years. A well in standby status by DDW means that it is only to be used for emergency situations and with prior approval from DDW. Customers will also need to be notified if a standby well is used. From discussions with DDW, the water system does not have plans to treat this well but will instead plan to drill a replacement well in the future.

### Dibromochloropropane (DBCP)

Dibromochloropropane (DBCP) is a synthetic organic contaminant with a MCL of 0.2 ppb based on chronic health effects. DBCP was a banned nematocide that may be still present in soils due to runoff or leaching from former use on soybeans, cotton, vineyards, tomatoes, and tree fruit.

If water over the DBCP MCL is consumed over many years, some people may experience reproductive difficulties and may have an increased risk of getting cancer.

The biennial report did not sample for DBCP, however during the review of water quality data for the water systems within Poso Creek, there were some water systems that had detections of DBCP. In the north, Earlimart has two wells with DBCP detections below half the MCL with steady trends. Directly south of Earlimart, Richgrove CSD has one of two wells that has fluctuating DBCP levels at half the MCL. Prior to 1999, results were over the MCL, now the well has results at half the MCL.

In the central region, the cities of Delano, Wasco, and Shafter have some detections. The City of Delano has six out of 15 wells with DBCP detections. All six have levels below half the MCL, with levels slightly above the detection limit for reporting. The City of Wasco has three wells with detections less than half the MCL. The City of Shafter has four wells with levels less than half the MCL. Due to the drought from 2012-2016, there was an increase in DBCP prevalence of this legacy pesticide. Results that were showing increased detections between this time frame were at levels slightly above the detection limit for reporting. Trend graphs presented below show this slight increase in concentration which is believed to be a consequence of severe drought conditions. Overall, DBCP is no longer a significant contaminant concern in Poso Creek region.

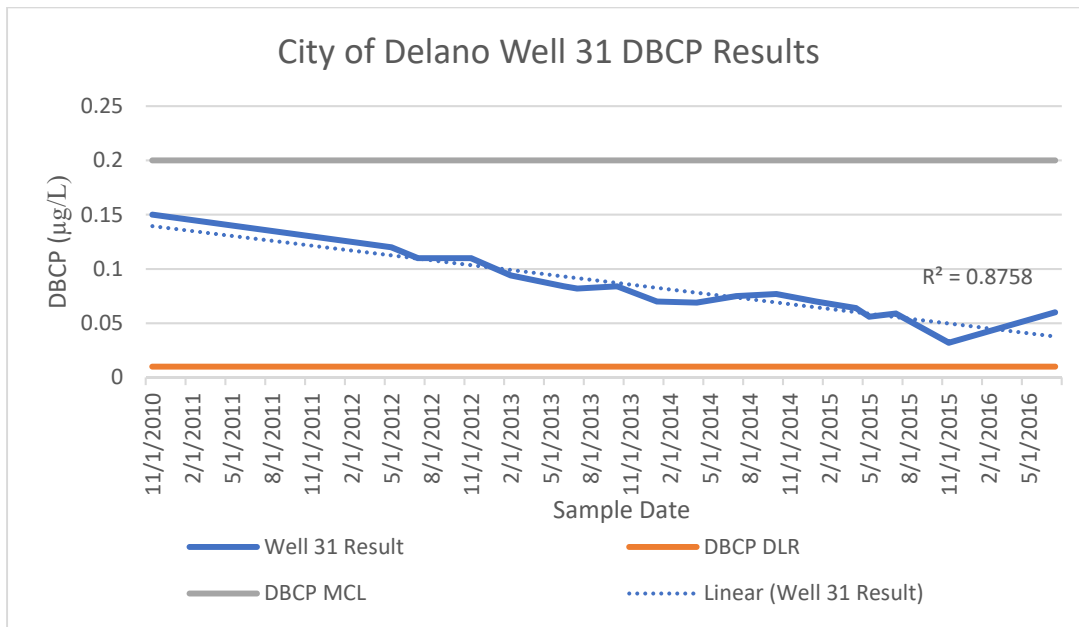

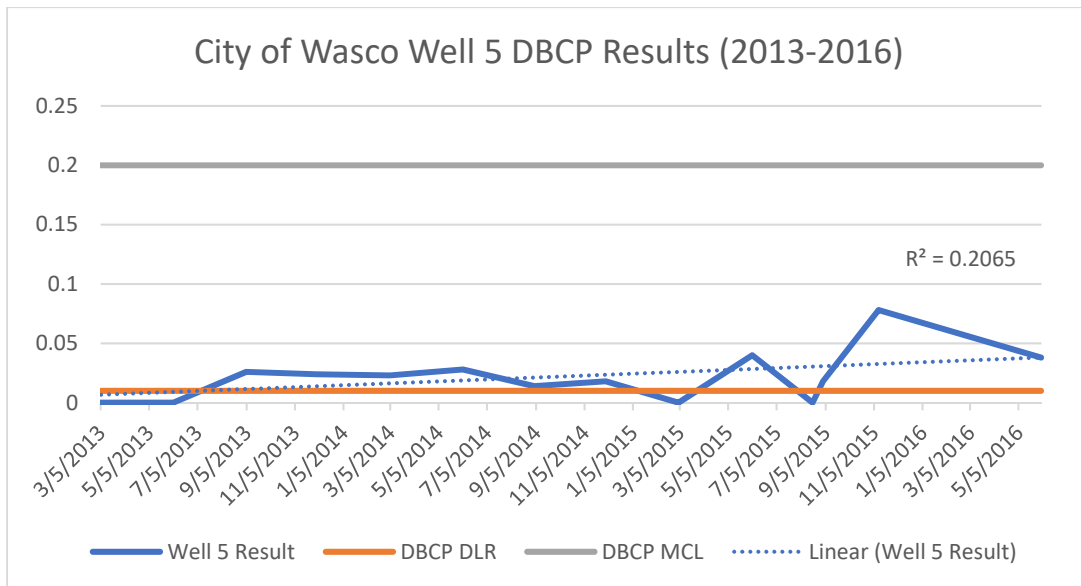
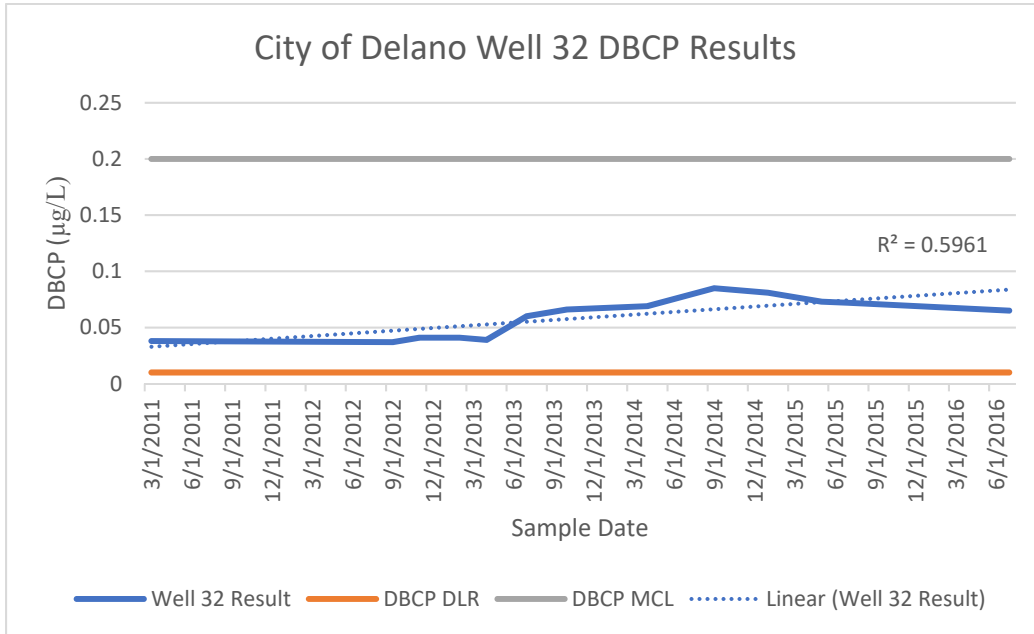

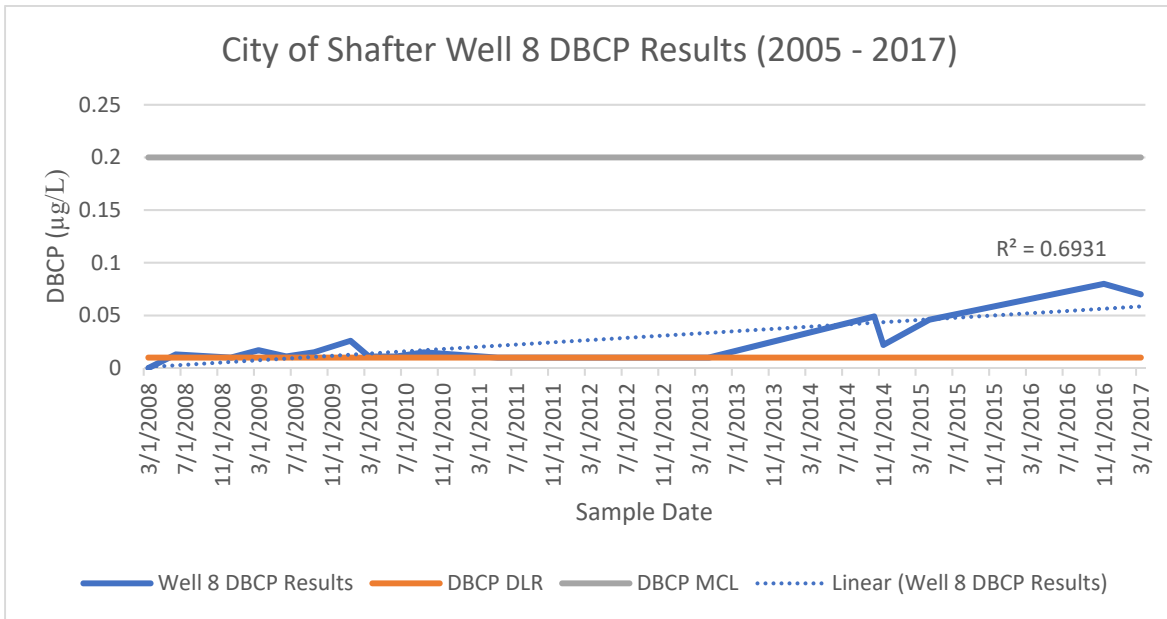

### 1,2,3-Trichloropropane (TCP)

TCP is a chronic contaminant with a newly adopted MCL of 5 parts per trillion (ppt). This was recently adopted by DDW on July 18, 2017. There is currently no federal MCL. TCP is a manmade compound. In the past, TCP was present as an impurity in certain soil fumigants (1,3-D soil fumigants) used to kill nematodes. TCP also has some limited industrial uses. When applied to land, TCP passes through soil and bonds to water, then sinks into the aquifer. It is a highly stable compound, meaning that it is resistant to degradation and has a half-life of hundreds of years<sup>2</sup>.

When water is consumed over the MCL over many years, some people may have an increased risk of getting cancer based on studies in laboratory animals. The effective date of the TCP MCL regulations was December 14, 2017. As of January 1, 2018, public water systems had to comply with this new MCL: all public systems are required to conduct initial monitoring and report their TCP results to the State.

Since the MCL is at the same level as the analytical reporting limit at 5 ppt, once there is detection, the source is considered over the MCL. Compliance with the MCL will be based on four consecutive quarters running annual average (RAA). If the RAA or the average concentration of the initial finding, confirmation sample(s), and six subsequent monthly samples exceeds the MCL, then the water system will be considered in violation of the TCP MCL. In addition, if a single sample exceeds the RAA, the well is considered in violation of the MCL.

---

<sup>2</sup> Transformation and biodegradation of 1,2,3-trichloropropane (TCP). 2012. <https://link.springer.com/content/pdf/10.1007%2Fs11356-012-0859-3.pdf>

According to DDW’s review of groundwater well data, the most impacted counties are Kern, Fresno, Tulare, Merced, and Los Angeles. Public water systems began testing for TCP in 2001 pursuant the Unregulated Contaminant Monitoring Rule. The data evaluation conducted for TCP looked at the first quarter of 2018 samples from DDW’s Drinking Water Watch database. Once the initial monitoring began in 2018 occurrence data from the State Water Board’s Division of Drinking Water (DDW) shows 388 statewide drinking water sources exceeded the MCL during the first quarter<sup>3</sup>. In Kern County, 51 water systems have 94 impacted wells (approximately 37 percent of their total wells). Table 1 summarizes the public data from municipal water systems within The Poso IRWM.

**Table 1. Summary of TCP Occurrences in Kern County Municipal Water Systems**

Water System	Affected Wells	Total Wells	Percent Affected	Concentration (ppt)	
				Max	Average
City of Delano	6	14	43	10	3
City of McFarland	1	3	33	20	7
City of Shafter	5	5	100	210	150
City of Wasco	5	5	100	77	48
Earlimart PUD	2	5	40	35	10
Richgrove CSD	1	2	50	7	4
Rodriguez Labor Camp	1	1	100	8	8
Wasco State Prison, Wasco	1	2	50	11	6
USDA Cotton Research Center, Shafter	1	1	100	214	184

Data includes active and standby wells; extracted from DDW TCP Occurrence Data as of June 2016

The City of Shafter is the only water system in the Poso Creek region that has installed TCP treatment using granular activated carbon (GAC). With TCP treatment, the TCP concentrations on the effluent has been consistently below the new MCL since late 2017. The current best available treatment for TCP is GAC. Seeing that monitoring began in 2018 for all water systems, they will need to review their results quarterly to ensure they are in compliance with the TCP MCL.

**Data Gathering for Private Wells:**

In addition to reviewing the water quality data from the public water systems, a significant amount of effort was made to obtain information regarding the private wells located in the Poso IRWM. Efforts to obtain the information such as the general location and the well construction of the

---

<sup>3</sup> 1,2,3-Trichloropropane Sampling in Q1 2018. June 2018. [https://www.waterboards.ca.gov/drinking\\_water/certlic/drinkingwater/123TCP.shtml](https://www.waterboards.ca.gov/drinking_water/certlic/drinkingwater/123TCP.shtml)

private wells were made by contacting the Kern and Tulare County Environmental Health Departments. It is anticipated that the well data obtained on the private wells will be shared with community organizations such as Self-Help Enterprises, to conduct an outreach program to private well owners for potential well head sampling. The Poso IRWM acknowledges that private well owners have not been represented and are part of the Disadvantaged, Underrepresented Communities (DUC). Including the future evaluation of the water quality data from the private wells provides a better understanding of water quality across all communities in the Poso IRWM and addresses the human right to safe and clean water adequate for human consumption. In addition, this follows along the guidelines in the Proposition 1 2016 IRWM planning efforts.

### **3.7 Ecological Processes and Environmental Resources within Region**

The development of land in the Poso Creek Region for agricultural and municipal purposes tends to have long-term ecological impacts, particularly for local (native) flora and fauna. Accordingly, proper identification and protection of areas to reduce future environmental impacts, is a key objective of the IRWM Group (reference Section 4.5, Measurable Objective “I”).

The North West Kern RCD (RCD), a member of the RWMG Participants, was established to provide an organized means to carry out programs for the conservation of soil and water; to prevent soil erosion, to control floodwaters and sediment damages; and to help farmers, ranchers and others to make the best use of their natural resources. Since establishment, the role of the RCD has expanded to include assistance to the county and towns that lie within and adjacent to the district, which includes a total area of about 594,000 acres in Kern County. The RCD has assisted the districts and agencies in the Poso Creek Region with monitoring of environmental resources, including wildlife refuges and duck clubs, and the measurement of on-farm irrigation efficiency for water conservation through use of the on-farm mobile irrigation assessment laboratory.

The US Department of Agriculture: Natural Resource Conservation Service (NRCS) also works with the districts and landowners in the Region to provide technical support for the conservation of land and water, the preservation or restoration of habitable lands, and other programs to help conserve resources. Participation in NRCS programs is voluntary, with the NRCS providing financial assistance for many of these activities and is usually targeted at the on-farm level. Moreover, the Endangered Species Recovery Program (ESR Program) established by the U.S. Fish and Wildlife Service presents an ecosystem approach to species recovery that applies to the Region, specifically the areas shown in Figure 3.4. The ESR Program primarily involves the management or enforcement of federally-threatened and -endangered species and includes any actions such as federal permitting, funding, or punishment for violation. With regard to these species, Kern County has more than two dozen threatened and endangered species, principally including, but not limited to, the San Joaquin Kit Fox, Tipton Kangaroo Rat, and the San Joaquin Woolly threads. Many of these species are expected to reside within the Region’s boundaries.

### *Bay-Delta Conservation Plan (BDCP)*

Implementation of projects and programs that support the State's co-equal goals, as defined in the *Amended Memorandum of Agreement Regarding Collaboration on Planning, Design and Environmental Compliance for the Delta Habitat Conservation and Conveyance Program in Connection with the California Bay Delta Conservation Plan* (BDCP 2011), will be considered. A 2013 BDCP Proposal was reviewed and will no longer be pursued as of the time of this update, and a modified proposed project is still under consideration. The implementation of co-equal goals is a way of providing reliable water supply for California, while enhancing, protecting, and restoring the Delta ecosystem and habitat (SB1, Steinberg- Section 85054) for Smelt, and Chinook Salmon. Recall from Section 3.5 that some of the districts within the Region contract for water supplies that must be pumped from the Delta and delivered via the Aqueduct. By improving the effectiveness of water storage and conveyance in the Region, which has been discussed throughout this Plan, the Region's reliance on "firm" supplemental surface water supplies is reduced, thereby supporting the environmental goals for both the San Joaquin River and the Sacramento-San Joaquin River Delta.

### *Wildlife Refuges and Water Demands*

The Kern National Wildlife Refuge (KNWR) is an approximately 1,249-acre refuge located in the northwestern portion of the Region which is managed by the US Fish and Wildlife Service (USFWS). It is a controlled habitat conservation area set aside as public lands to protect local wildlife and plants (shown in Figure 3.5). The RWMG maintains communication with the KNWR Staff and has considered possible water supply conveyance projects that may benefit the KNWR and the conservation goals of the USFWS and the California Department of Fish and Game.

Since the passage of the Central Valley Project Improvement Act (CVPIA) in 1992, 19 State, Federal, and privately-owned refuges annually provide critical managed wetland habitat for a host of water-dependent wildlife. The Refuge Water Supply Program is managed jointly by the U.S. Fish and Wildlife Service and Bureau of Reclamation and consists of several program components which include: the acquisition of refuge water supplies; the construction of conveyance systems to deliver those water supplies; and the conveyance of the refuge water itself. The KNWR is one of the federal refuges that now receive a reliable source of water to help satisfy some of the yearly habitat requirements for species that use the refuge. Prior to the enactment of CVPIA legislation, most of these refuges relied upon surplus water storage, agricultural return flows, junior water rights and groundwater for their supply, all sources that were either unreliable or of marginal quality, or both. The CVPIA legislation mandated an allotment of secure, reliable water to these refuges, which range as far north as Glenn County and as far south as Kern County (in the Central Valley of California).

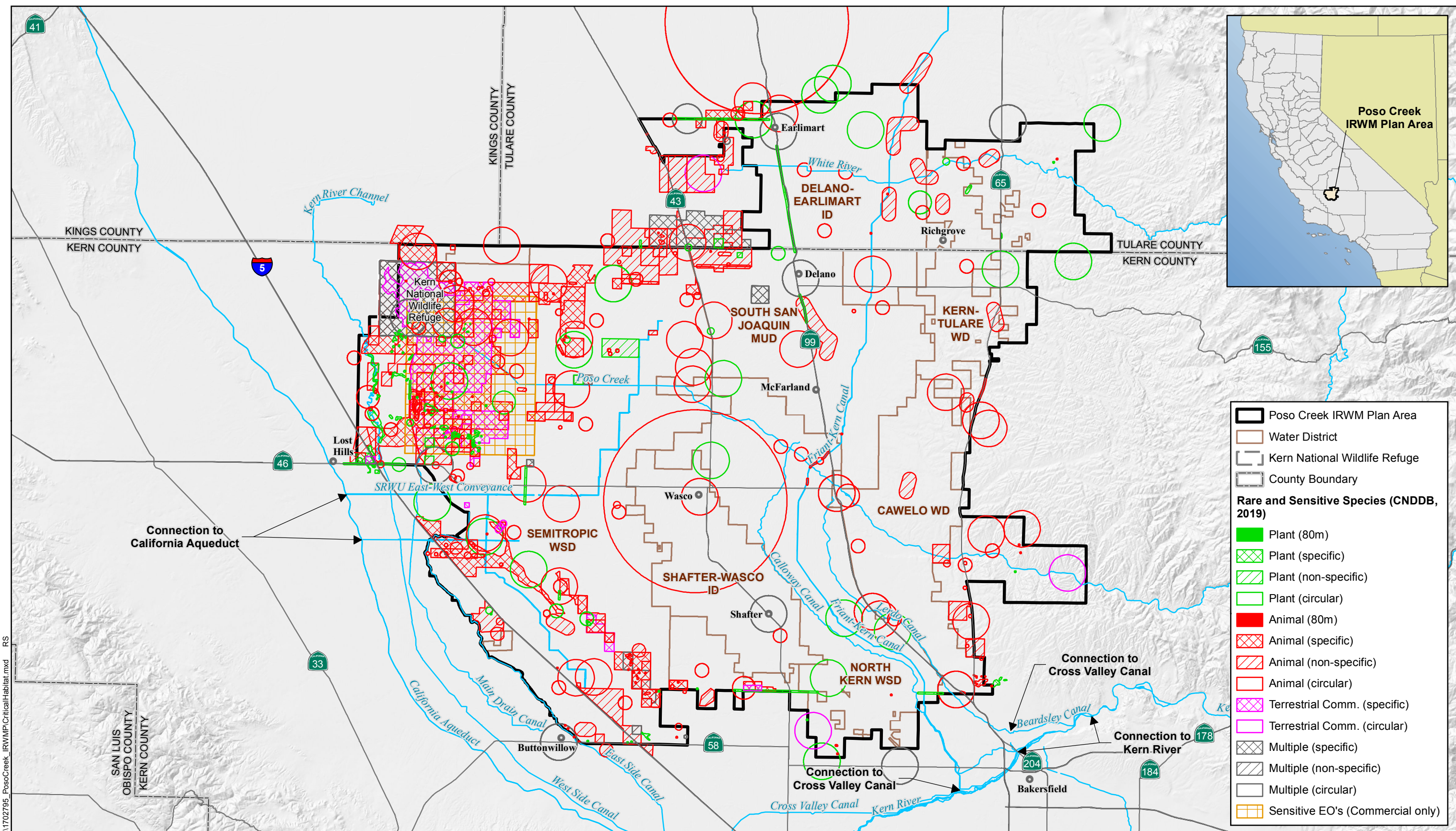

**Poso Creek IRWM Plan Area**

- Poso Creek IRWM Plan Area
- Water District
- Kern National Wildlife Refuge
- County Boundary

**Rare and Sensitive Species (CNDDDB, 2019)**

- Plant (80m)
- Plant (specific)
- Plant (non-specific)
- Plant (circular)
- Animal (80m)
- Animal (specific)
- Animal (non-specific)
- Animal (circular)
- Terrestrial Comm. (specific)
- Terrestrial Comm. (circular)
- Multiple (specific)
- Multiple (non-specific)
- Multiple (circular)
- Sensitive EO's (Commercial only)

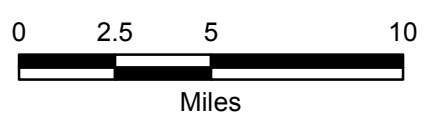

2019 Integrated Regional Water Management Plan (IRWMP) Update  
Kern and Tulare Counties, California

Poso Creek IRWM Group



**CRITICAL HABITAT CONSERVATION AREAS**

JUNE 2019

FIGURE 3.4

29-May-2019 Z:\Projects\1702795\_PosoCreek\_IRWMP\CriticalHabitat.mxd RS





**Figure 3.5** Kern National Wildlife Refuge  
(US Fish & Wildlife Service credited for photograph).

With the benefits of water supplies provided by the CVPIA, refuge managers, including those at the KNWR, can now plan for at least one irrigation of their moist soil food plants, provide breeding ponds for waterfowl and colonial nesting birds such as white-faced ibis, great-blue herons and egrets. This allows for late summer habitats for the first birds migrating south spending the winter in the Central Valley. However, all these beneficial habitat management practices are limited in scope each year because of the limited amount of water made available to these areas. Often, only one irrigation may be accomplished each year, while 2 or 3 are preferred, and the acres of brood habitat or later summer habitat is usually less than what is needed to support the numbers of wildlife utilizing the refuge.

A significant component of species recovery is establishing a network of conservation areas and reserves that include terrestrial and riparian natural areas in the San Joaquin Valley, such as the KNWR. As part of their efforts to support species recovery, the Metro Bakersfield Habitat Conservation Plan (HCP) and the Kern Valley Floor HCP have established endangered species recovery programs in the San Joaquin Valley to promote species recovery. See Figure 3.4 for a map of the critical habitat conservation areas as defined for the Region. The RWMG understands the need to safeguard the ecological processes and environmental resources within their boundaries.

### 3.8 Water-Related Recreation Land Use

Recreational water use in the Region is limited to the KNWR on the northwest side of the Region (shown in Figure 1.1) and several “duck clubs”, which are located in the same portion of the Region. Specifically, water demands are attributable to grain irrigation and/or flooding ponds for waterfowl, including duck clubs.

Lakes for water recreation in Kern County that are outside of the Poso Creek Region include the Isabella Reservoir, also known as Lake Isabella (shown in Figure 3.6), and Lake Ming, both of which are located east of the City of Bakersfield and impound Kern River water. Others include Lake Woollomes, which adjoins the Friant-Kern Canal (east of Delano) and serves as a regulating reservoir for Friant-Kern Canal operations; and the Buena Vista Aquatic Recreation Area, also known as the combination of Lake Webb and Lake Evans, which is near the California Aqueduct, southwest of Bakersfield (and outside of the Poso Creek Region). Recreational activities on these lakes primarily include camping, fishing and boating. The USACE is responsible for day-to-day reservoir operations at Lake Isabella, while the Kern County Parks and Recreation Department administers the recreational activities at each of these locations.



**Figure 3.6** Isabella Reservoir Recreational Area

Although North Kern WSD exercises its rights to conservation space in Isabella Reservoir for the regulation of its Kern River supplies, no deliveries of water are made explicitly for recreational use. Accordingly, any recreational use of RWMG Participant water supplies is incidental to the storage of water in reservoirs, for the purpose of regulating the delivery of surface water supplies.

### **3.9 Urban and Industrial Lands and Disadvantaged Communities**

According to the 2018 U.S. Census estimates, Kern County’s population was over 896,000 which represented an increase of about 7% percent over 2010 Census data. As of the 2017 U.S. Census Bureau’s “QuickFacts” the estimated 2017 population of Kern County is almost 900,000. Available demographic data indicates that approximately 34 percent of people are white (non-Hispanic), 53 percent are Hispanic, 6 percent are African-American, 5 percent are Asian, and 2.6 percent are Native American. The median household income in the County was listed as \$49,788, (40% increase from \$35,446 in 2014), with 22.4 percent of homes below the poverty line (32.4 percent of children under 18 and 11.8 percent of adults age 65 and older live in conditions below the poverty level). Over twenty-one percent of the households in Kern County received means-tested public assistance or non-cash governmental benefits in 2018.

The largest urban area in Kern County, and in the southern San Joaquin Valley, is the City of Bakersfield (located immediately southeast of the Region) with a 2010 population of about 347,000 and estimated population of 381,000 in 2017 (which is about 42 percent of the total for the County as a whole). Based on recent estimates, approximately 120,000 people presently reside within the Region, which is about double the estimate for 1990. The cities of Delano, McFarland, Shafter, and Wasco, along with the unincorporated communities of Earlimart, Lost Hills, and Richgrove are located within the Region and are shown in Figure 3.7. Several smaller population centers in outlying areas support processing facilities for agricultural and petroleum products. There are no Native American tribal communities located in the Region.

Many of the communities in the Region are considered “economically disadvantaged” based on a comparison of the statewide median household income (\$71,805 for 2017 based on ACS Census 1-year survey data, or \$61,094 using ACS data for the years 2009-2013) to the population-weighted average household income level for the Region (approximately \$30,294 as of 2014, which is about 50 percent of statewide value, with any updated economic data for the Region being reflected in future updates). This value falls well below the 80% of statewide median household income threshold (value \$48,875, since Proposition 1 uses the ACS data for the years 2009-2013) for designation as “economically disadvantaged”, in accordance with CWC §79505.5(a). This implies that most unincorporated communities are classified as “disadvantaged communities” (DACs). The CWC also defines “severely disadvantaged communities” (SDACs) as those with median household income below 60 percent of the statewide value, which results in a threshold of approximately \$40,643 (or \$36,657 if using ACS data for the years 2009-2013) which only applies to some of the poorest of areas in the Region.

Given that DACs are in the Poso Creek Region, identifying the water supply and water quality needs of these low-income areas is necessary for the IRWM Group. The RWMG has taken proactive steps for identifying and including DACs in development of the Plan. Following the identification of economically-disadvantaged areas, representatives were extended an invitation to

participate in the IRWM Group. Several communities that met the criteria for DACs joined the Poso Creek IRWM Group and have participated since its formation. A list of DACs in the Region is given in Table 3.7, and a map of the locations of these DACs is shown in Figure 3.7. Recall from Section 2.2 that DACs are represented by a DAC Representative who is a voting member of the RWMG, as well as a DAC Work Group that focuses on the needs, impacts, and benefits to communities in the Region. For the DAC communities that remain unrepresented, or are located outside the Region boundary, the IRWM Group has worked with Self-Help Enterprises and the Community Water Center to identify and provide needs assessment of unincorporated disadvantaged communities. More on the involvement of these entities, as well as all DACs, in the planning and implementation efforts of the IRWM Group is described in Section 11.3.

The DACs in the Poso Creek Region have several significant obstacles to overcome to ensure reliable water supplies and adequate water quality for their residents. Some of these obstacles include the following:

- Lack of financial resources due to lower-income residents, many of whom are not able to adequately fund community projects and programs (i.e., lower tax income for these communities and limited involvement from residents). In addition, many of these communities struggle to provide basic services such as maintenance, permitting, and staff to address the needs and issues of their residents.
- Lack of technical and managerial ability of community leadership and personnel to plan and afford the necessary steps for assuring water quantity and quality. It also relates to being unable to hire skilled staff and provide competitive income levels, thereby perpetuating the lack of leadership capacity, specifically regarding water-related concerns.
- The water and wastewater infrastructure of many of the DACs in the Region are substandard or aging, relying on old or severely leaking wells and distribution systems leading to many water challenges. Recall that all cities and communities in the Region rely solely on groundwater (reference Section 3.4). Some of these wells are shallow, inadequately constructed, or improperly sealed, which leads to poor water pressure and/or poor water quality.
- Many of the DACs are geographically isolated, located long distances from larger cities or more economically prosperous areas.

The IRWM Group has worked with the DACs with the intent of providing solutions to regional water supply and quality issues; regardless of location (some of the DACs are located outside the Region boundary), status/condition (e.g., comparison of level of economic-disadvantage between DACs), or ability to participate in IRWM Group efforts. Through the DAC Representative (reference Section 2.2), the RWMG will continue its outreach to DACs and encourage participation in the IRWM Group (as stated in Section 11.4). The IRWM Group has

supported project and program development and implantation for these DACs, with a good deal of success, which is illustrated in Appendix A1.

Regarding the use of groundwater supplies by these DACs, the RWMG has identified and implemented projects and programs that benefit the underlying groundwater basin (as stated in Section 3.4). In this regard, recall that the agricultural water management districts and DACs, as well as other cities and M&I users, share a groundwater basin that is hydraulically connected and utilized by all users in the Region. Accordingly, any decline in water levels will be felt by all users, including the regional DACs that rely on the groundwater for their supplies due to an associated increase in the use of power and energy resources (environmental burden), as well as infrastructure (well) upgrades which become necessary to pump groundwater from deeper in the aquifer. To that extent, projects and programs such as those which were implemented (Appendix A1) or those which are proposed as part of this Plan (Appendix A2) which work to mitigate declines in water levels will provide benefits to other groundwater users in the Region. Beyond projects and programs aimed specifically at improving water supply or water quality issues at the DAC-level (e.g., construction or rehabilitation of a groundwater well), the types of activities described in this Plan provide benefit to the DACs in the Region through the common groundwater reservoir.

This Plan Update contemplates that DAC-specific projects and programs will be included in the Annual Report, pursuant to the Regional Goals and Measurable Objectives outlined in Sections 4.4 and 4.5, respectively. It is noted that project and program submissions to the RWMG are expected to address potential impacts and benefits to regional DACs, which is a factor that is weighted during review of project/program submissions (reference Section 5.1). Beyond the list in the Annual Report, it is intended that the DAC Representative and Work Group will work with DAC leadership in the Region to maintain a current list of the DACs and their primary contact information. Representatives from Self-Help Enterprises and the Community Water Center are invited to participate in the IRWM Group meetings, and to call for the inclusion of specific projects or programs with a DAC focus, when it comes to grant and funding applications to accomplish the Goals and Objectives of this Plan.

**Table 3.7** Characteristics of the Region's Disadvantaged Communities

<b>City/Community</b>	<b>County</b>	<b>Population<sup>1</sup></b>	<b>Estimated Households</b>	<b>Median Household Income (MHI)<sup>1</sup></b>	<b>% of State MHI<sup>2</sup></b>	<b>Corresponding Entity</b>
Allensworth <sup>3</sup>	Tulare	561	136	\$29,091	39%	Allensworth Community Services District
Alpaugh <sup>3</sup>	Tulare	1,124	285	\$38,750	34%	Alpaugh Community Services District
Blackwells Corner	Kern	Not Avail.	Not Avail.	\$29,338	48%	Berrenda Mesa Water District (BMWD)
Buttonwillow	Kern	1,324	400	\$34,352	62%	Buttonwillow County Water District
Delano	Kern	52,538	11,690	\$36,265	58%	City of Delano
Unincorporated Areas West of Delano	Kern	Not Avail.	Not Avail.	\$30,946	51%	County of Kern, City of Delano
Ducor <sup>3</sup>	Tulare	741	199	\$30,288	55%	Ducor Community Services District
Earlimart	Tulare	8,677	2,026	\$23,561	43%	Earlimart Public Utility District
Lost Hills	Kern	2,013	508	\$30,583	48%	Lost Hills Utility District
McFarland	Kern	13,391	2,988	\$33,687	59%	City of McFarland
Pond	Kern	48	24	\$30,946	51%	Pond Mutual Water Company

<sup>1</sup> Data obtained from the latest US Census Bureau statistics, generally 2016 American Community Survey Data (available via American Fact Finder online database) or 2010 Census Data.

<sup>2</sup> Percent of State MHI from 2010 ACS Census Data, threshold of \$61,094 with 80% value of \$48,875, as stated above (from Prop. 1 Guidelines, which use ACS data for the years 2009-2013)

<sup>3</sup> Located outside of Poso Creek IRWM Region.





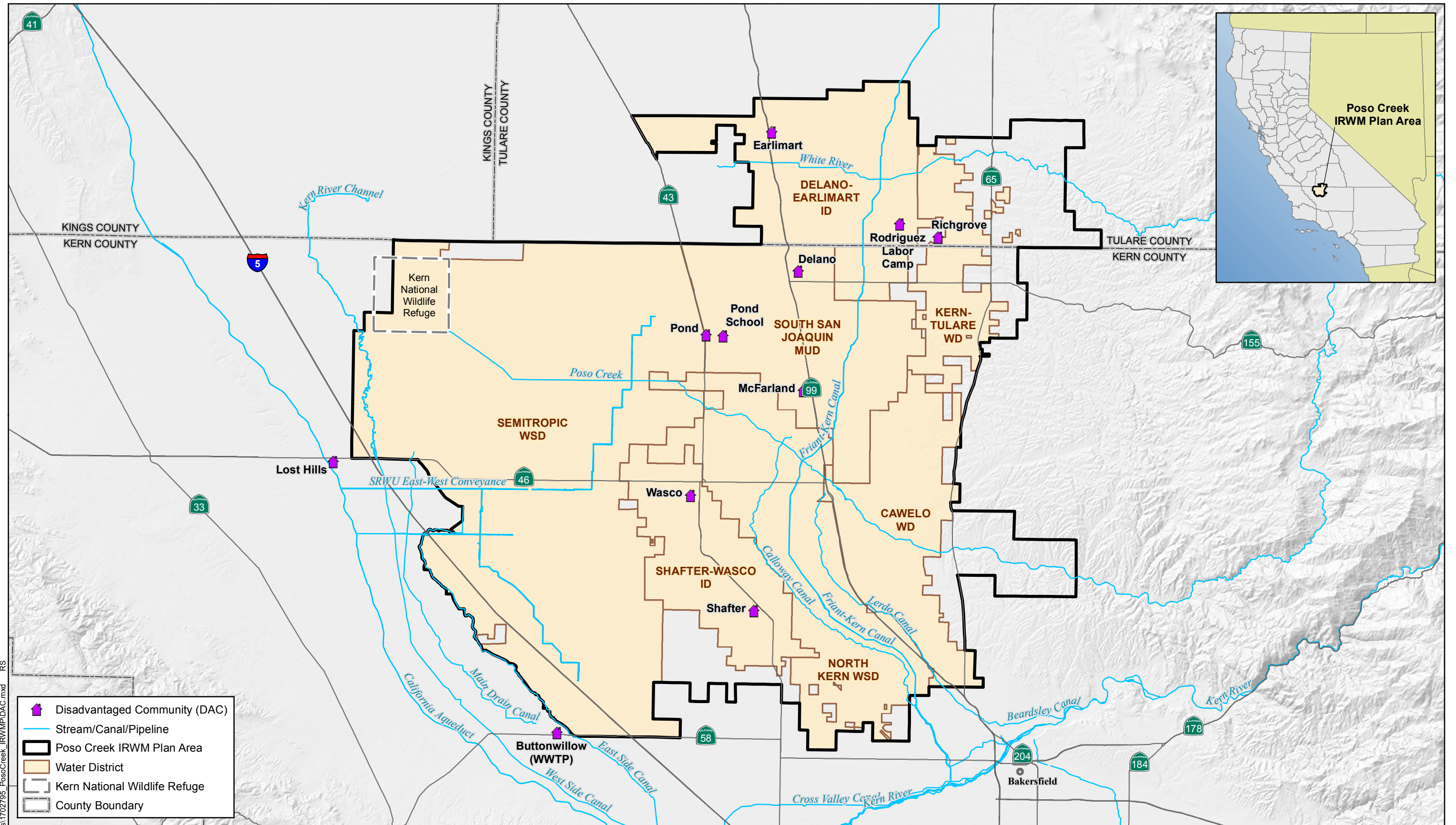

**Table 3.7 (Continued)** Characteristics of the Region's Disadvantaged Communities

City/Community	County	Population <sup>1</sup>	Estimated Households	Median Household Income (MHI) <sup>1</sup>	% of State MHI <sup>2</sup>	Corresponding Entity
Pond School District	Kern	250	Not Avail.	\$30,946	51%	Pond School District
Poplar Avenue Community						
Richgrove	Tulare	3,096	674	\$30,116	49%	Richgrove Community Services District
Rodriguez Labor Camp	Tulare	111	24	Not Avail.	Not Avail.	Richgrove Community Services District
Semitropic School District	Kern	263	NA <sup>1</sup>	\$29,338	48%	Semi-Tropic School District
Shafter	Kern	17,801	4,727	\$41,085	67%	City of Shafter
Shafter North (North Park & North Shafter)	Kern	1,000	207	\$27,634	45%	City of Shafter
Shafter South (Smith's Corner, Thomas Lane, Cherokee Strip, Burbank, Mexican Colony, Southwest Shafter)	Kern	1,300	348	\$27,634	45%	County of Kern, City of Shafter
Sierra Vista	Tulare	44	13	\$33,382	46%	County of Tulare, City of Delano
Wasco	Kern	26,061	5,536	\$39,559	69%	City of Wasco

<sup>1</sup> Data obtained from the latest US Census Bureau statistics, generally 2010 Census Data (available via American Fact Finder online database).

<sup>2</sup> Percent of State MHI from 2010 ACS Census Data, threshold of \$61,094 with 80% value of \$48,875, as stated above (from Prop. 1 Guidelines, which use ACS data for the years 2009-2013)



-  Disadvantaged Community (DAC)
-  Stream/Canal/Pipeline
-  Poso Creek IRWM Plan Area
-  Water District
-  Kern National Wildlife Refuge
-  County Boundary

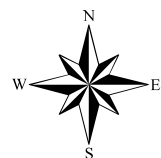
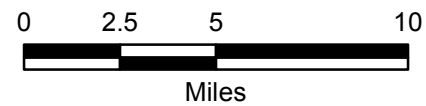

2019 Integrated Regional Water Management Plan (IRWMP) Update  
Kern and Tulare Counties, California

Poso Creek IRWM Group



LOCATION OF DISADVANTAGED COMMUNITIES  
IN THE POSO CREEK REGION

JUNE 2019

FIGURE 3.7



### **3.10 Social, Cultural, and Economic Trends of the Region**

As discussed in Section 3.0, the economy of the Region is based on irrigated agriculture. Reasonable land costs and smaller-sized communities have perpetuated this Region as a predominantly agricultural area. In other words, there has been little disruption in farming practices due to urbanization or decreased economic viability. However, the largely “open” areas, combined with relatively lower land costs in comparison to other urbanized areas of California, make the Region a potential area for population growth over the next few decades. In particular, the proximity to the City of Bakersfield, which is located just south of the Region and is the largest urban area in Kern County, increase the likelihood of increased pressured to convert adjacent farm land to urban uses. Urban growth will challenge some of the Region’s resources, including wastewater collection and treatment, environmental resources, industrial water needs, and principally the ability to supply adequate drinking water resources to an expanding population.

Economic and social development in the Region requires an adequate and stable water supply. Given that cities and communities in the Region rely on groundwater pumping to meet demands; it is important to maintain groundwater levels for all uses. Within the Region, the agricultural districts are responsible for importing supplemental surface water supplies which recharge the groundwater reservoir. The conjunctive-use practices of these districts have served to reduce the stress on the underlying aquifer, which benefits all those who rely on groundwater, including the cities and communities in the Region. In particular, the relatively higher groundwater levels help assure that pumping lifts remain economically viable.

Despite the success of the agricultural-based economy, the Region still faces unemployment, lower wage levels for employees (on average), and areas of poverty as described in Section 3.9. Many of the communities and cities are working to mitigate these issues by creating jobs and expanding the economic base, particularly in their connection to the local agricultural-based economy that includes expansion and improvement of farmworker jobs. However, there are several social and cultural trends that make these efforts difficult. According to 2012-2016 data, between 20 and 25 percent of those residing in the San Joaquin Valley were foreign-born leading to prevalent cultural barriers in and around the Region. More than 40 percent of people speak a language in their home other than English. The Region is home to many hard-working people, labor and business leaders, and entrepreneurs – of various backgrounds – who are working to better the living conditions and economy of the Region. Many of the communities in the Region are comprised of farmworkers or persons associated with agricultural-based employment. To that

extent, it is essential that the Region's agricultural economy remains viable, with economically competitive crops, modern growing and effective irrigation practices, and a reliable water supply.

### **3.11 Appropriateness of the Region for an IRWM Plan**

Since the formation of the water management districts and agencies in the Region, water resources management has been based on the conjunctive use of supplemental surface water supplies with the common groundwater basin. Since the groundwater basin is a shared resource, the districts are all actively involved in the management of imported surface water supplies, and several districts operate groundwater banking projects, the formation of a regional water management group (RWMG) was logical. In this way, water supply and demand management were approached through cooperative and mutually beneficial planning efforts. The Region's assets, including State, Federal, and local water supplies (reference Sections 3.1 and 3.5), proximity to major conveyance facilities (Section 3.3), and significant groundwater storage and absorptive capacities (Sections 3.3 and 3.4), also made it an ideal location to enhance the existing conjunctive-use practices through regional cooperation and management. The RWMG Participants each faced common issues; principally, maintenance of a reliable water supply and balancing the use of surface water and groundwater. The individual districts and agencies that formed the RWMG also had a history of working together based on prior water management arrangements, including water transfers and exchanges, water banking agreements, shared water conveyance networks, and cooperative management efforts. The formation of the RWMG simply took this to a new level.

The Poso Creek Region lies within a specific portion of the Tulare Lake Basin Hydrologic area, known as the Poso Hydrologic Unit, as defined by the SWRCB (SWRCB 1975). As shown in Figure 1.1, it is in the northerly portion of Kern County and southerly portion of Tulare County. Figure 3.8 shows the relationship of the RWMG to the Poso Hydrologic Unit. The Region boundary was influenced by several factors, including the following:

- Political and jurisdictional boundaries of districts participating in the joint planning effort;
- Natural surface water systems and rights to those sources;
- Access and rights to multiple sources of surface water supplies and surface water conveyance systems within the plan area, and for conveying water to or from the plan area;
- Access to a common groundwater basin;
- Common watershed boundaries and sub-units;
- Land use, particularly irrigated agriculture, waterfowl habitat and preserves, and sensitive upland species habitat of significant yet manageable size;

- Topography and geography to economically provide water for irrigation; and,
- Common floodplains and flooding issues;

As described in more detail in Section 3.3, the RWMG not only shares a common groundwater basin, the districts have access to several local and regional water supplies and conveyance systems. For these reasons, the Poso Creek Region was chosen as an area that was poised to leverage its diverse portfolio of water supplies and infrastructure for the common purpose of improving water supply reliability within the Region. It is in keeping in accordance with this that SSJMUD has joined the Poso Creek IRWM Group, since it shares many of the above features with other previous members of the Group and had an existing relationship with them owing to shared resources and proximity.

Furthermore, throughout the IRWM planning and implementation process, the boundary of the Poso Creek Region has evolved to encompass some adjacent but “unorganized” areas. These areas are similar in most respects excepting that they are not included within an organized district. As part of Plan implementation during the Region Acceptance Process, the Poso Creek Region Boundary was modified along the north and east to conform to neighboring IRWM Groups and was additionally modified to the east to include an area along Poso Creek channel where a flood control reservoir has been considered in past studies.

Owing to the common groundwater, management practices, and concerns, it is logical that, through working together, water management programs can be accomplished which help to meet the overarching goal of improving the reliability of the Region’s water supplies that could not otherwise be accomplished. Several water banking and exchange agreements have been accomplished as a result of the dialogue and information exchange afforded by the IRWM planning process. Specific examples include moving wet-year water into districts that have available absorptive capacity and subsequently returning previously stored water in future dry years. The IRWM Group ‘Report Card’ in Appendix A1 provides some specific examples of projects and programs which have been completed and are able to function as a direct result of the integrated regional planning.

### *Neighboring or Overlapping IRWM Regions*

The Poso Creek Region is bounded by The Tulare Lake Basin Portion of Kern County IRWM Plan (Kern IRWMP) and the Tule IRWM Plan (Tule IRWMP), which is shown in Figure 1.1. The Poso Creek IRWM boundary was coordinated with neighboring regions, which included the overlap with the Kern IRWMP. Defining the Region boundaries was a requirement of the

DWR's Region Acceptance Process (RAP). Accordingly, as part of the RAP, a formalized agreement was reached between the Poso Creek IRWM Group and the Kern IRWMP in September 2010 defining the boundaries of the two planning efforts within Kern County. Regarding the DAC Communities within the Poso Creek IRWM Group, some have maintained a 'dual' participation in both IRWMs to increase their opportunities for advancing their projects and to be eligible for funding assistance. The Poso Creek IRWM Group continues to work cooperatively with the Kern IRWMP to effectively address inter-regional water management issues, which includes a dialogue to coordinate planning and implementation programs funded by the DWR.

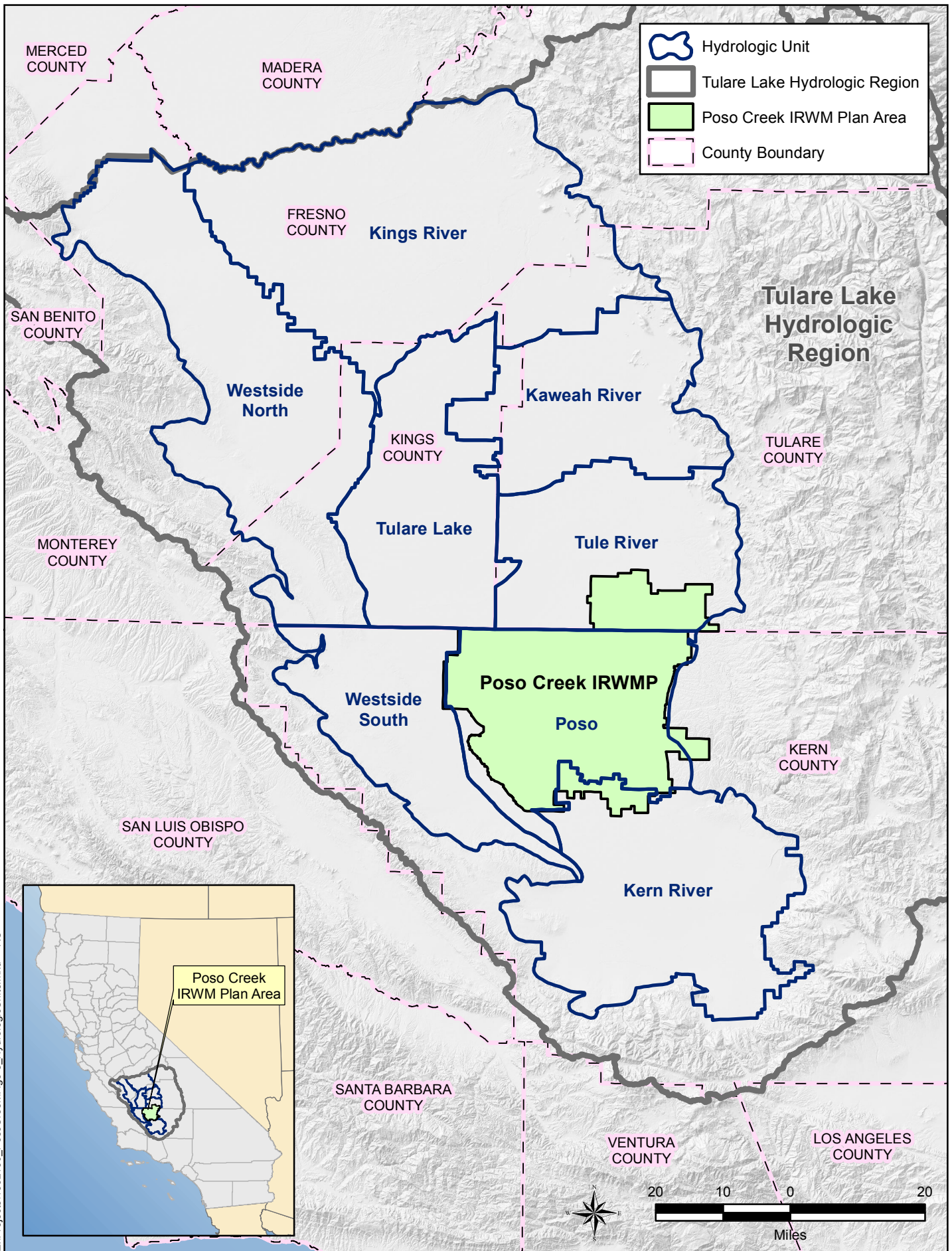

15-May-2014 Z:\Projects\1332150\_PosoCreek\Fig3-8\_HydrologicUnits.mxd RS

2014 Integrated Regional Water Management Plan (IRWMP) Update  
Kern and Tulare Counties, California

Poso Creek IRWMP Group



Relationship of RWMG to Poso Hydrologic Unit

JUNE 2014

FIGURE 3.8

## 4.0 Regional Goals and Measurable Objectives

In accordance with the IRWMP Proposition 1 Program Guidelines, this section addresses the ‘Objectives’ and ‘Resources Management Strategies’ Plan Standards, which includes the requirements shown in the following table (along with identification of the specific subsection(s) where each requirement is addressed).

<b>Requirement</b>	<b>Plan Section(s)</b>
Determine IRWM Plan objectives.	4.5
Collaborative process and tools used to establish objectives, including how they were developed, what information was considered, groups involved in development, and how final decisions are made.	4.1, 4.2, 4.3, 4.4, 4.6, 4.7, 4.8, 4.9, 4.10
Quantitative or qualitative metrics and measurable objectives.	4.5
Prioritization of objectives, or reason why not prioritized.	4.4
Specific overall goals for region.	4.4, 4.6
Address adapting to changes in the amount, intensity, timing, quality and variability of runoff and recharge.	4.6
Consider the effects of SLR on water supply conditions and identify adaptation measures.	4.6
Consider reducing energy consumption, especially the energy embedded in water use, and reduce GHG emissions.	4.6
Consider strategies adopted by CARB in the AB32 Scoping Plan.	4.6
Consider carbon sequestration options and renewable energy.	4.6
Consider and incorporate all RMSs into IRWM Plan.	4.8
Consider Climate Change effects on region factored into RMSs.	4.8
Address which RMSs will be implemented in achieving plan objectives.	4.8
Demonstrate how the effects of climate change on the region are factored into the RMS.	4.6, 4.8
Consider reducing energy consumption and ultimately GHG emissions.	4.6
Evaluation of RMS and other adaptation strategies and ability of such strategies to eliminate or minimize those vulnerabilities.	4.8

During Plan formulation, the Poso Creek RWMG developed and evaluated Regional Goals and Measurable Objectives (both qualitative and quantitative) that provide a basis for all regional planning efforts. Regional Goals (Goals) are defined as the highest level priorities for the region, adhering to the RWMG’s overarching Vision and Mission, while Measurable Objectives (Objectives) are more specific actions that can be taken to meet one or more of the goals. For this Plan, the Objectives were evaluated for compliance with the DWR Statewide Priorities, per the IRWMP Proposition 1 Program Guidelines, and the regionally-applicable “Resource Management Strategies” (RMS) presented in the California Water Plan Update 2013 (California Water Plan). The definition and assessment of the IRWM Goals and Objectives, and the adherence to planning requirements, is described below along with the process used to identify them in later sections.

## 4.1 Regional Vision and Mission

The RWMG developed Vision and Mission statements to refine the Region’s priorities and solidify their regionally focused planning and implementation activities. The Vision statement provides guidance and inspiration as to what the RWMG is focused on achieving in the future. The Mission statement defines the purpose of the RWMG, and what the *group* strives to accomplish in its management and planning efforts. Both statements were approved by IRWMP Participants, Stakeholders, and Interested Parties during the development of the Plan. Both the Vision and Mission statements were formalized by the RWMG in the First Amendment to the MOU, as seen in Appendix C.

### *Poso Creek RWMG Vision Statement*

“Provide a framework for the Poso Creek IRWMP Participants, Stakeholders, and Interested Parties to identify and coordinate resource management activities through Regional Goals and Measurable Objectives.”

### *Poso Creek RWMG Mission Statement*

“Facilitate plans, programs, and projects necessary to meet the Regional Goals and Measurable Objectives, and to further sustainable resource management.”

## 4.2 Previous Plan Objectives

In the original 2007 IRWMP, seven ‘Planning Objectives’ were developed to provide a framework for formulating the Region’s priorities and selecting strategies and proposed projects to meet those priorities. The original Planning Objectives are listed and described below, restated from the Original Plan:

1. **Water Supply Reliability.** Two of the significant problems facing the Region are surface water supply reliability and maintaining groundwater levels. The intent of this objective was to meet annual-average and critical-period regional demands, minimize localized shortages, improve system flexibility, and identify water supply reliability improvements through conjunctive use measures at the regional and local level.
2. **Groundwater Levels.** The intent of this objective was to help insure that groundwater levels will be maintained or enhanced with economically viable pumping lifts through increased conjunctive use operations.
3. **Groundwater Quality.** Groundwater quality in the Region is generally good (Section 3.6); thus, the intent of this objective was to focus on protecting quality of groundwater and enhancing water quality when practical.

4. **Water Supply Costs.** The focus of this objective was to maintain water supply costs at a level commensurate with the continued viability of the agricultural economy which has developed in the Poso Creek Region.
5. **Monitoring.** Groundwater monitoring is a vital objective for the Region to ensure the proper management and protection of its resource. The focus of this objective was to enhance ongoing monitoring of groundwater levels and water quality as needed as part of the implementation of projects.
6. **Environmental Resources.** Maintaining and enhancing environmental resources within and outside the Region was the focus of this objective, which included protection and enhancement of a number of wetlands within the Poso Creek Region that provide an ecosystem of fowl, flora, and wildlife. Also acknowledged was the connection between the Region's imported supplies and the environmental issues surrounding the Sacramento-San Joaquin River Delta (Delta) and restoration of the San Joaquin River.
7. **Flood Management.** The objective was focused on enhancing flood control to provide flood protection for the health and safety of the Region's population, while minimizing flood damage losses and seeking balanced management solutions with respect to cost and monetary/non-monetary benefits.

These Planning Objectives were also developed in recognition that improved water resources management would benefit inhabitants throughout the Region as well as water purveyors in other parts of California while satisfying Regional priorities. These priorities considered the IRWMP Proposition 50 Program Guidelines and the RMS presented in the California Water Plan Update 2005.

It is noted that the Planning Objectives expressed in the 2007 IRWMP adhered to the groundwater monitoring and assessment emphases of the Proposition 50 Guidelines. These objectives were reviewed during the development of the Regional Goals and Measurement Objectives in the 2014 Plan Update, and again in this 2019 Update. The updated goals and objectives continue to illustrate that the RWMG has since broadened their focus from water resource (specifically groundwater) management planning to more generalized resource management planning within the Region, including expanding the discussion of water supply and demand with environmental and climate change assessment related to implemented projects and programs.

### 4.3 Goals and Objectives Development Process

Besides reviewing the previously developed Planning Objectives, development of the 2019 Goals and Objectives included consideration of Regional priorities and planning requirements identified from the following sources:

1. Consideration of changes to the water related needs of RWMG Participants, Stakeholders, and Interested Parties;



2. Consideration of State goals and priorities from the 20x2020 Water Conservation Plan (i.e., related to water use efficiency);
3. Review of Basin Management Objectives (BMOs);
4. Consideration of California Water Code §10540 through §10543;
5. Consideration of the 2012 DWR IRWMP Proposition 84 Guidelines (2012);
6. Consideration of the 2016 DWR IRWMP Proposition 1 Guidelines (2016); and
7. Consideration of strategies adopted by CARB in the AB32 Scoping Plan.

Key participants and Stakeholders have remained active in developing the planning structure and development hierarchy used by the RWMG. All Regional Goals and Measurable Objectives were identified by the RWMG Participants, Stakeholders, and Interested Parties as adhering to the Regional priorities and the RWMG Vision and Mission statements. The hierarchy and regional framework used during development of the Plan, and through implementation of various projects and programs, is shown in Figure 4.1. Shown in this figure are typical ‘planning efforts’ and ‘implementation’ tasks, illustrating the connection between the work performed by the RWMG and the overall “planning process”.

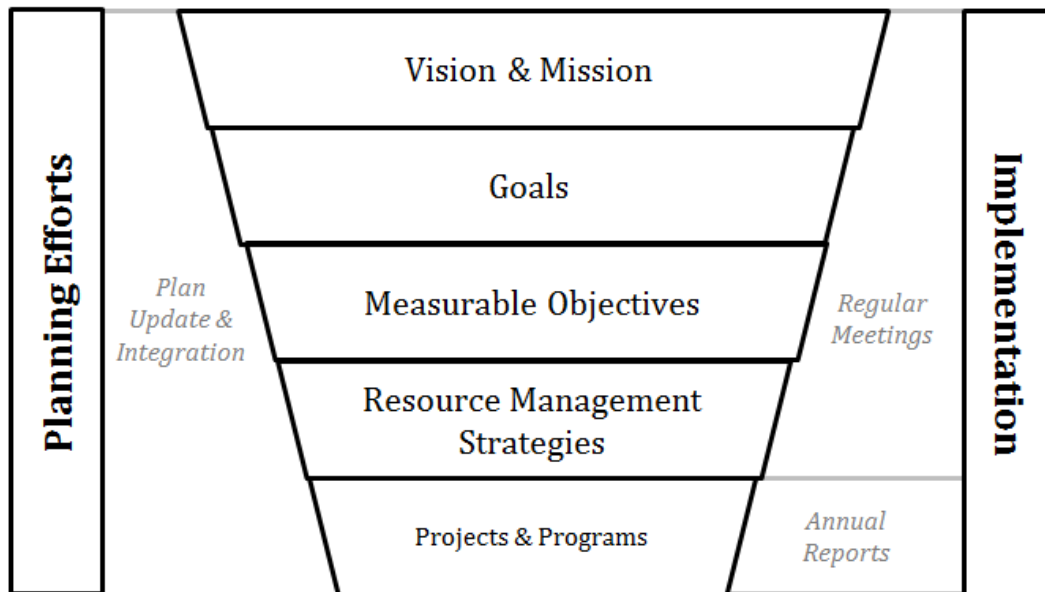
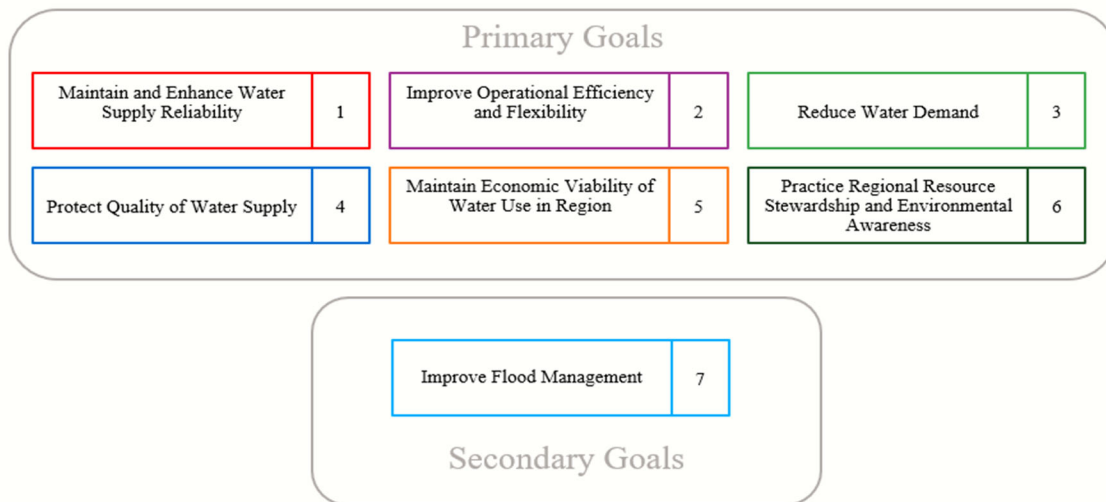

**Figure 4.1** Regional Framework and IRWMP Planning Hierarchy.

Note that the connection between levels of the planning structure with Vision & Mission, Goals are not 1:1, such that, more than one Regional Goal or RMS may apply to one or more Measurable Objective. Specific Regional Goals and Measurable Objectives are discussed in the following two sections.

## 4.4 Regional Goals

The heightened emphasis towards climate change considerations in planning efforts, as compared to the 2014 IRWMP, required revisions to the Goals in order to fully complement the IRWM Group’s increased efforts under Proposition 84 and Proposition 1. This is not meant to suggest that the 2014 Planning Objectives (listed in Section 4.2) are no longer considered important to the IRWM Group and the RWMG, or that they no longer adhere to the Regional priorities; rather, the RWMG Participants, Stakeholders, and Interested Parties have assumed increased responsibility towards resource planning in the Region, and are adjusting their methods to account for increasing environmental concerns. The IRWM Goals, (shown in Figure 4.2), are seen as the highest-level priorities for the Region, consolidating municipal, agricultural, social, economic, and environmental concerns.



**Figure 4.2** Poso Creek IRWM Regional Goals

The RWMG has determined that, based on Regional priorities, Goals 1 through 6 are designated as “Primary Regional Goals”; Goal 7, while valuable to the planning and management efforts of the Region, is designated as a “Secondary Regional Goal”. Goal 6 was considered a “Secondary Goal” in the 2014 IRWM update, but 2016 DWR IRWMP Proposition 1 Guidelines have since prioritized consideration of climate change related parameters, and the Region has responded by making resource stewardship and environmental awareness a primary goal for future projects to accomplish. The emphasis on the Primary Regional Goals is such that projects and programs primarily associated with these goals have direct benefits and noticeable impacts on the more environmentally sustainable balancing of water supplies and demands related to changing quantities of imported surface water or pumped groundwater for the Region. The Secondary Goal is to promote effective management of Regional flood control.

Due to the overwhelming need within the Region to meet the Primary Regional Goals, which are related to regional water supply and accommodating climate change concerns, the RWMG’s approach has been to meet the Secondary Regional Goal, where appropriate, by integrating it into a project or program that meets one or more of the Primary Regional Goals. The selection of projects or programs, based on Primary and Secondary goals, is discussed in Section 5.1. A detailed description of each of the Regional Goals, and the connection to the Measurable Objectives, is presented in Section 4.6.

## 4.5 Measurable Objectives

The IRWM Objectives were developed as a means of accomplishing the Goals, to directly support the DWR Statewide Priorities and the RMS applicable to the Region, and to identify projects and programs suitable for implementation to meet the Regional Priorities of the RWMG Participants, Stakeholders, and Interested Parties. Along with the Goals from Section 4.4, the following Objectives, shown in Figure 4.3, address the requirements of the CWC §10540 and §10541.

<b>A</b>	Enhance reliability of surface water supplies delivered to region.	<b>J</b>	Identify drinking water quality issues of communities, water-related needs of DAC’s, and consider improvements.
<b>B</b>	Identify any significant threats to groundwater resources from overdrafting.	<b>K</b>	Implement regional opportunities, projects, and programs.
<b>C</b>	Improve regional water conveyance, direct recharge, and in-lieu service areas.	<b>L</b>	Implement region-wide water management actions.
<b>D</b>	Increase absorptive capacity within the region.	<b>M</b>	Maintain compliance with State and Federal planning requirements.
<b>E</b>	Promote regional conjunctive water-use.	<b>N</b>	Maintain coordination between Poso Creek RWMG Participants and Interested Parties.
<b>F</b>	Support groundwater monitoring activities.	<b>O</b>	Adapt to changes in the amount, intensity, timing, quality, and variability of runoff and recharge.
<b>G</b>	Maintain and enhance quality of water supply.	<b>P</b>	Reduce energy consumption, especially the energy embedded in water use, and ultimately reducing GHG emissions.
<b>H</b>	Enhance region-wide flood control measures.	<b>Q</b>	Consider strategies adopted by CARB in its AB 32 Scoping Plan 1.
<b>I</b>	Promote environmental conservation and support wildlife habitat enhancement.	<b>R</b>	Consider options for carbon sequestration and using renewable energy for IRWM project implementation.

**Figure 4.3** Poso Creek IRWM Measurable Objectives

The Objectives identified in Figure 4.3 are assessed using measurement metrics that allow, in a practical means, monitoring achievements and quantifying progress in RWMG planning and implementation efforts. These metrics, described in connection with the Objectives in Table 4.1, are further discussed in Section 7.3 with regards to project and program monitoring.

**Table 4.1** Measurement Metrics for Poso Creek IRWM Measurable Objectives

<b>Measurable Objective Letter(s)</b>	<b>Qualitative or Quantitative Metric</b>	<b>Measurement Metric</b>
A, C, D, E, L, O, P	Quantitative	Measure AF/Y delivered to Region. Identify deliveries to irrigation demand, in-lieu and direct spreading, to match total supplies with demand.
B, C, D, E, F, L, O	Quantitative	Measure static groundwater depth and annual changes in groundwater levels; as well as acres of irrigated land relying only on groundwater use.
C, D, H	Quantitative	Measure (cfs) of conveyance capacity increase, acres of in-lieu service areas, and acres of direct spreading grounds. Also measure changes in absorptive capacity (AF/M or AF/Y).
C, J, K, L, N, O, P, Q, R	Qualitative	Maintain list and reporting of regional resource management enhancement opportunities, through projects and programs
F, G	Quantitative	Report quality of water delivered into Region and within the service areas, such as TDS and other constituents.
H, O	Quantitative	Maintain, track, and report additional flood storage/storm water management in Region (in AF).
I, P, Q, R	Qualitative/ Quantitative	Document projects that support environmental and energy conservation efforts in the Region; record the area of habitat enhancement (in acres) and the amount of GHG emissions saved (in CO <sub>2</sub> -eq).
J	Qualitative	Facilitate coordination of DAC studies, identify and develop community projects and programs, and document community implementation efforts.
M	Qualitative	Track requirements and maintain list of Regional and District-level planning requirements and required water management documentation.
N	Qualitative	Facilitate minimum of quarterly Public Meetings. Maintain E-mail communication list, annual solicitation of projects, and periodic reporting.

## 4.6 Regional Goal and Measurable Objective Linkage

The Goals, and their connection to specific Objectives, are described below in the context of Regional priorities. As previously mentioned, it is noted that some of these objectives apply to multiple Goals.

### *No.1 Maintain and Enhance Water Supply Reliability*

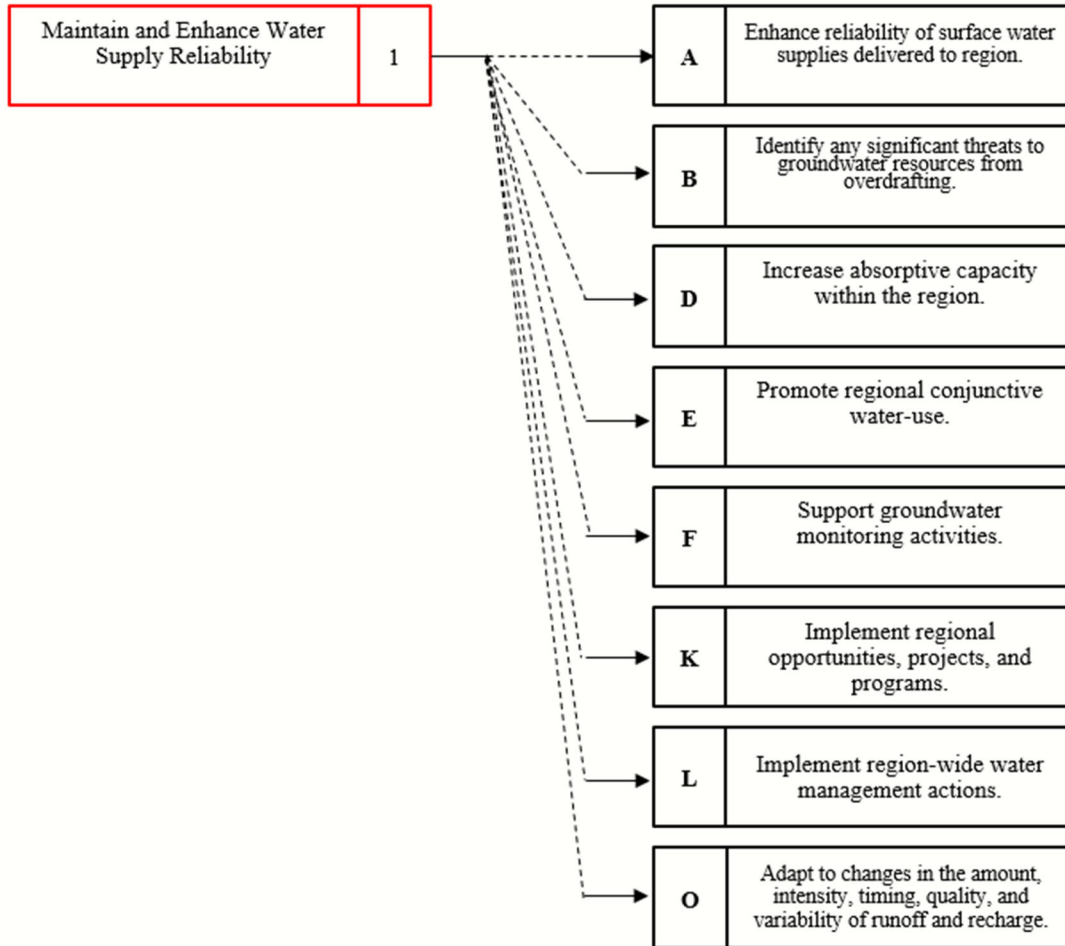

**Figure 4.4** Connections between Measurable Objectives and Regional Goal No. 1

Reliability of imported surface water supplies remains the most critical water concern in the Region, particularly as it relates to regulatory and operational constraints outside of the Region that have limited surface water deliveries to the Region. Reductions in the delivery of supplemental surface water supplies result in a commensurate increase in the use of groundwater. Urban and agricultural demands are met from the same groundwater basin; however, only the agricultural districts have the conveyance facilities and water supply contracts to supplement the

groundwater with surface water supplies. Furthermore, climate change's impact on the variability of runoff and recharge has only enhanced the need for water supply reliability. This goal is intended to help ensure that the reliability of an adequate, supplemental surface water supply and viable groundwater supply is maintained and improved to meet current and future local and regional water needs. Figure 4.4 illustrates the connection between this goal and the Objectives listed in Section 4.5.

## *No. 2 Improve Operational Efficiency and Flexibility*

Operational efficiency and flexibility are simply good “water management”; however, their importance is amplified in the context of maintaining the reliability of the Region’s water supplies. Uncertainty related to surface and groundwater sources can put stress on inflexible water storage and conveyance systems to meet demand. One crucial case of this uncertainty involves potential changes in the amount, intensity, timing, quality, and overall variability of runoff and recharge. Climate change has and will continue to exacerbate runoff and recharge variability, necessitating the consideration of these parameters in plans for improving operational efficiency and flexibility in this 2019 update more than in prior IRWMs. Improvements to regional operational efficiency and delivery flexibility can be affected through structural improvements that enhance the efficient use of water conveyance and delivery canals, as well as non-structural improvements, which could include measures that seek to improve flexibility in the delivery of water for irrigation. Adapting to accommodate variations in recharge and runoff, though helped by these efforts, will be furthered by more sophisticated water storage projects in the Region so that unexpected deficiencies or surpluses of water can be better managed. One such example of an effort made by the Region to improve operational efficiency and delivery flexibility is the lining of the NKWSD Canal, discussed more in Chapter 5. The intent is to maximize the delivery of available surface water supplies to meet the annual average and critical-period regional water demands; capture and otherwise regulate short-term supplies, such as stormwater; minimize localized shortages; and identify additional sustainable water supplies at the regional and local level. Figure 4.5 illustrates the connection between this goal and the Measurable listed in Section 4.5.

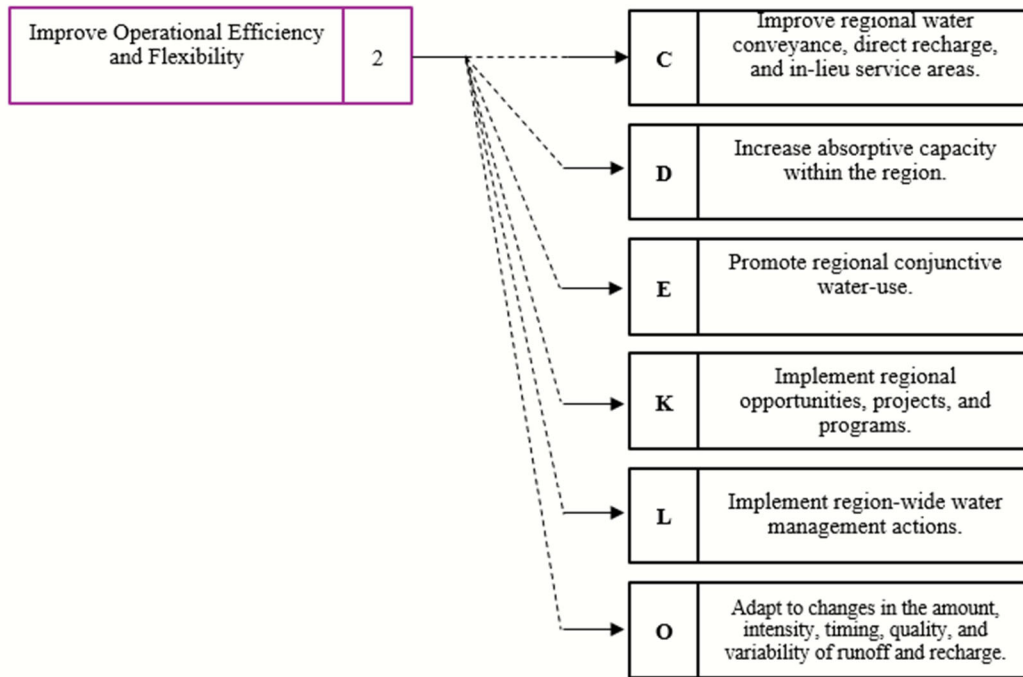

**Figure 4.5** Connections between Measurable Objectives and Regional Goal #2

### *No. 3 Reduce Water Demand*

Consideration must be given to methods for reducing water demand in the Region since the reliability of the Region’s water supplies is a major issue. To the extent that the percentage of irrigated acres planted with permanent crops has increased (see Section 3.5), the Region’s water demand has become more “hardened” over time, which means a firmer, more constant supply is required to maintain and irrigate crops. Reductions in surface water supplies available to the Region make it more difficult to mitigate or alleviate additional groundwater use which will occur in order to meet the hardening crop demand over time. Therefore, reduction in water demand has been identified as a goal in order to mitigate the loss of supplemental surface water supply and to help meet the competing water needs of agriculture, urban, and environmental water users in the Region. Figure 4.6 illustrates the connection between this goal and the Measurable listed in Section 4.5.

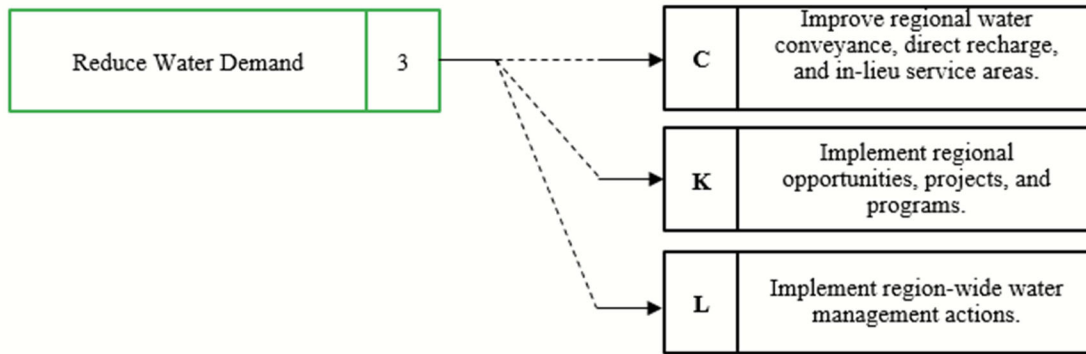
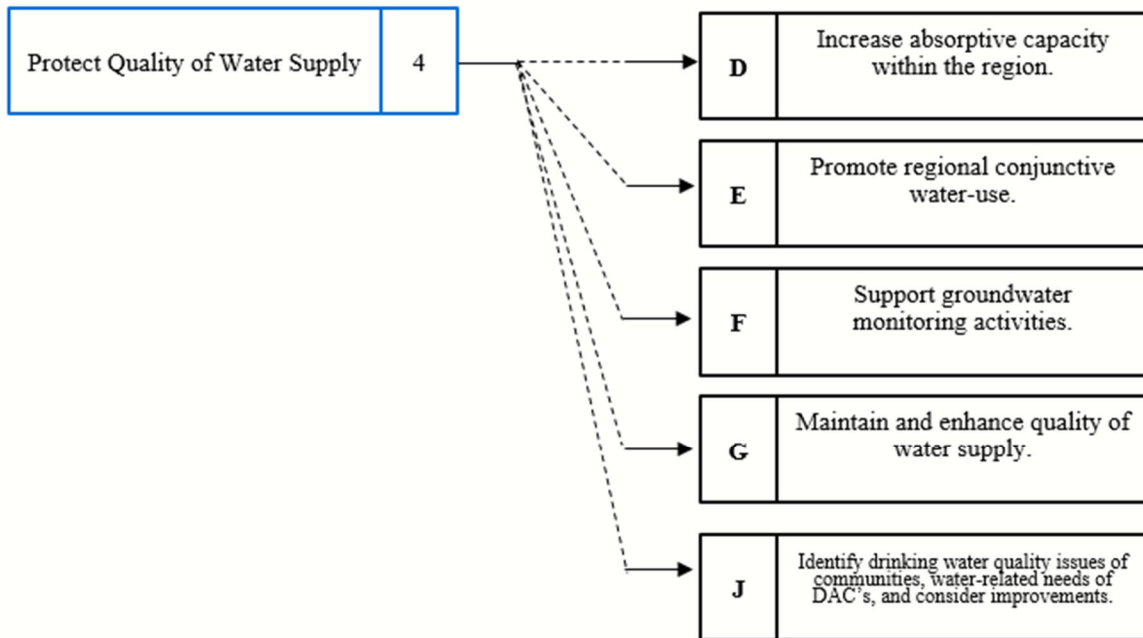

**Figure 4.6** Connections between Measurable Objectives and Regional Goal No. 3

#### *No. 4 Protect Quality of Water Supply*

The quality of both the underlying groundwater and the surface water supplies is generally suitable for irrigation and other beneficial uses. The salinity of the Region’s surface water supplies varies by source. The lower salinity supplies are the local Kern River water and the imported CVP-Friant water (San Joaquin River); whereas, the imported SWP water is typically higher in salinity. While the Kern River water and CVP-Friant water retain more of the character of the Sierra snowmelt, the character of the SWP water is modified as it is conveyed through the Sacramento-San Joaquin River Delta. Long-term issues which the IRWM Group and RWMG must consider include the importation of salts (with the imported water supplies) as well as exchanges which result in the use of supplies which are of lesser quality. The communities in the Region currently rely exclusively on groundwater and some face challenges in complying with drinking water standards for nitrate (NO<sub>3</sub>), arsenic, or other constituents. This goal focuses on protecting and enhancing the quality of groundwater and surface water used for municipal, agricultural, and environmental purposes within the Region. Figure 4.7 illustrates the connection between this goal and the Objectives listed in Section 4.5.

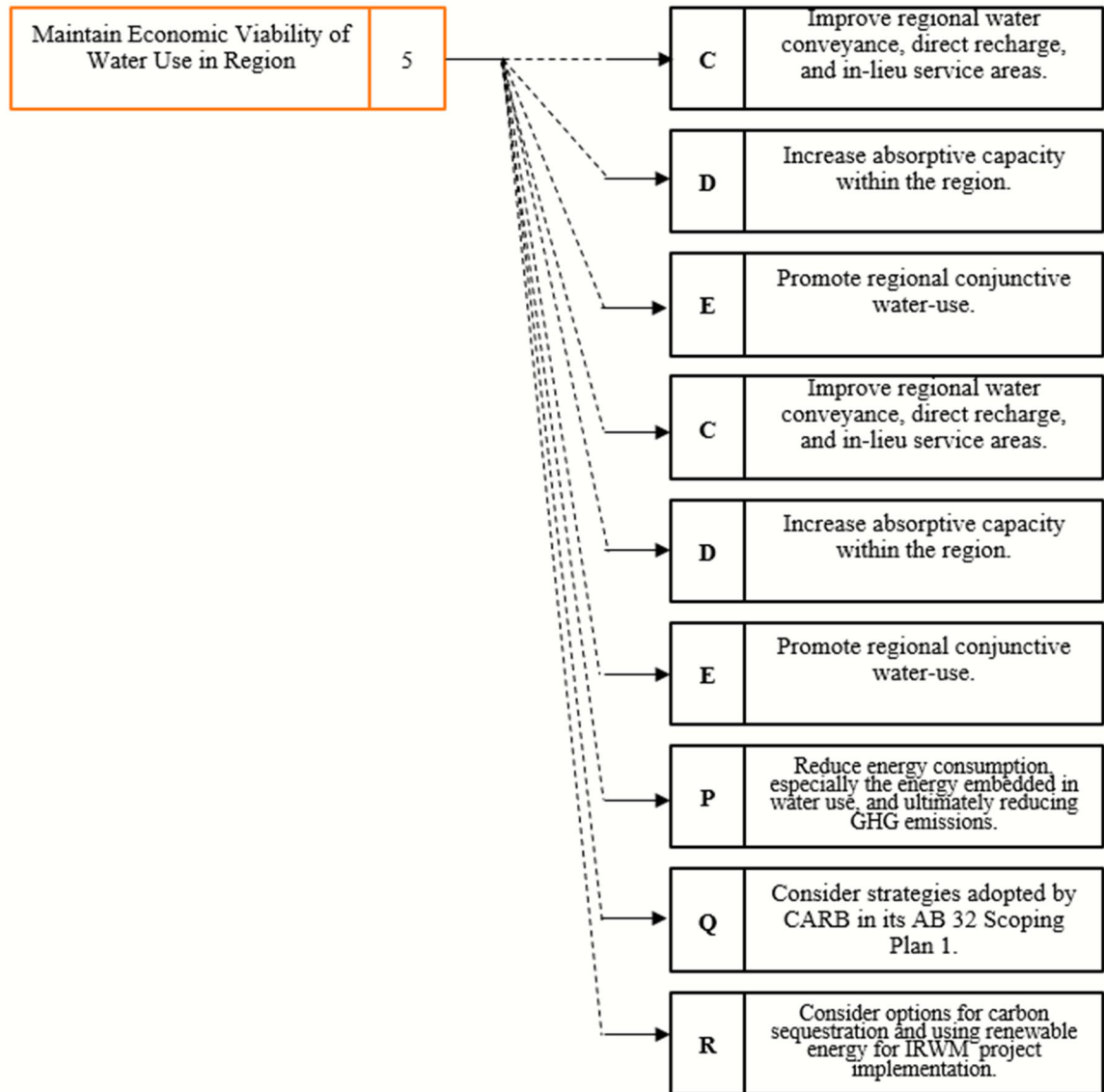



**Figure 4.7** Connections between Measurable Objectives and Regional Goal No. 4

*No. 5 Maintain Economic Viability of Water Use in Region*

The RWMG is committed to striving to maintain economically viable pumping lifts for growers in the Region. Since agriculture in the Region produces crops for both local and world markets, maintaining a competitive role in the marketplace is a key factor to maintaining the Region’s economic stability. Among other factors, the use of water supplies, including pumping groundwater or importing supplemental surface water, must remain economically viable. Furthermore, reducing energy consumption related to water use will not only be environmentally beneficial, but also economically, as costs associated with energy use will diminish accordingly. Thus, this goal focuses on maintaining water supply and energy costs at a level commensurate with the continued economic viability of the Region’s agricultural economy; maintaining reasonable and economically viable lifts for environmental water uses; and assisting communities with identifying reasonable solutions to meet drinking water needs. Figure 4.8 illustrates the connection between this goal and the Objectives listed in Section 4.5.

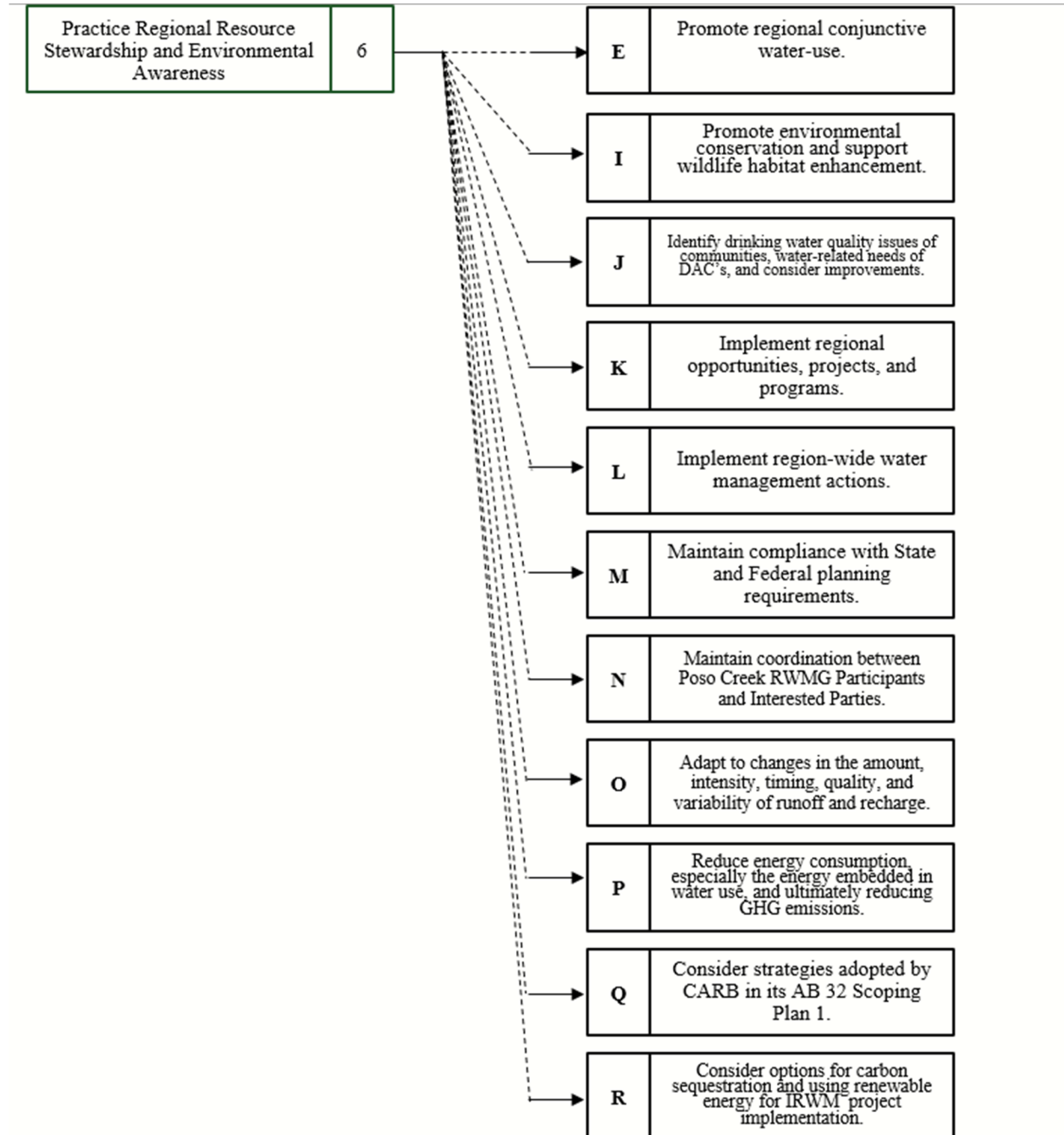

**Figure 4.8** Connections between Measurable Objectives and Regional Goal No. 5

*No. 6 Practice Regional Resource Stewardship and Environmental Awareness*

There are wetlands and associated uplands within and surrounding the Region that provide important habitats for migratory birds and other wildlife. In addition, the connection between the RWMG’s imported water supplies and the environmental concerns in the Sacramento-San Joaquin Delta and the Water Management Goal of the San Joaquin River (SJR) Restoration Program is well documented. This goal illustrates the RWMG’s commitment to environmental stewardship and awareness in the Region, as well as working to alleviate environmental concerns from the use

of imported surface water supplies from other watersheds and regions. Figure 4.9 illustrates the connection between this goal and the Measurable listed in Section 4.5.



**Figure 4.9** Connections between Measurable Objectives and Regional Goal No. 6

Note that adapting to the effects of sea level rise is not a priority for the Region since it is far enough inland to observe negligible effects. However, the Region will adapt to climate

change impacts pertinent to water supply, such as variability in runoff and recharge. Furthermore, the Region will implement water use-related projects to curtail energy consumption, use alternative energy, seek carbon sequestration options, and reduce contributions to greenhouse gas (GHG) emissions in all new and ongoing projects. This contributes to the AB 32 Scoping Plan, which created a program intended to reduce GHG emissions in California to 1990 levels by the year 2020. Members of the IRWMMG acknowledge that global climate change-related impacts are generated by project activities, both direct and indirect. For each project, the project-level cumulative emissions are considered against the likelihood that 1) the No-build Alternative would ultimately result in a project being developed outside of California to meet the demand that created the proposed project need, or 2) that state goals will continue to reflect the weighted average emissions on a per capita or per a gross state product basis. Each level (project specific, statewide, and federal) serves as an element of the whole GHG analysis and is not to be considered separately. If any level exceeds the thresholds defined for this analysis, then the GHG impact is considered significant and unavoidable. The baseline for every analysis for each project varies by the specific regulatory framework and way that the emissions and impacts are ultimately determined. These policy objectives are driven by executive orders and legislative acts such as AB 32.

### *No. 7 Improve Flood Management*

Flood protection is related to the health and safety of the Region's population, primarily in rural communities; minimizing flood damage losses of the various land uses; and seeking balanced management solutions with respect to cost and monetary/nonmonetary benefits. This goal is focused on improving and adapting flood management procedures and infrastructure to provide flood protection for the Region, especially as climate change exacerbates the variability of runoff and recharge. Figure 4.10 illustrates the connection between this goal and the Objectives listed in Section 4.5.

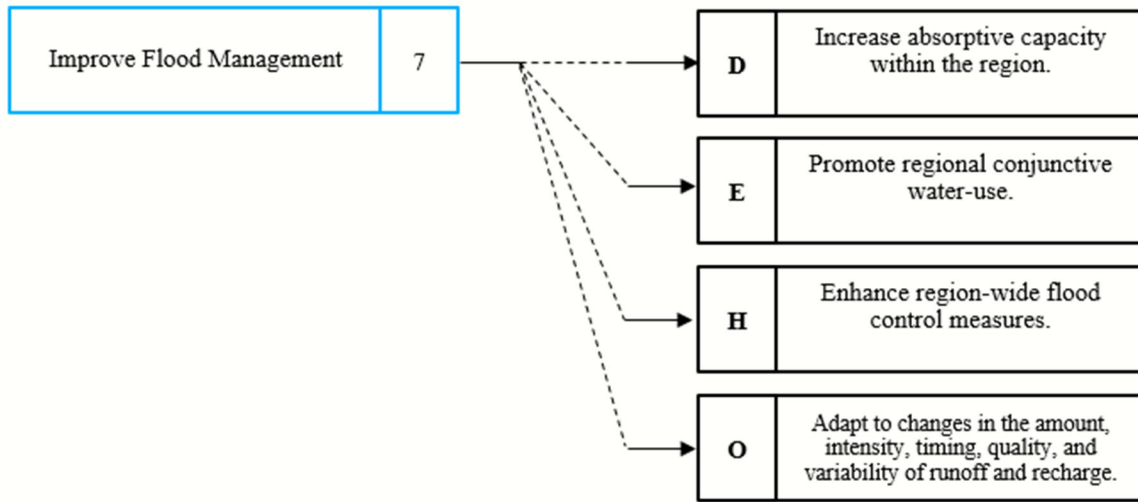

**Figure 4.10** Connections between Measurable Objectives and Regional Goal No. 7

#### 4.7 Program Preferences and Statewide Priorities

Consideration of the 2016 DWR IRWMP Proposition 1 Guidelines was given during development of the 2019 IRWM Regional Goals and Management Objectives. Within these guidelines, the State of California has established and listed 15 Statewide Program Preferences (formerly Program Preferences and Statewide Priorities) for IRWMPs, which should be addressed during the IRWM planning process. Each of the Program Preferences is addressed in this Plan and Table 4.2 indicates the consistency between the Measurable Objectives and those preferences. It is noted that the connection between the Objectives and the RWMG’s Goals was previously identified.

**Table 4.2** IRWMP Program Preferences

Priority No.	Program Preference	Measurable Objectives
1	Prioritize projects that leverage various funding or produce the greatest public benefit.	K, M, N
2	Employ new and innovative technology or practices.	A, B, C, D, E, F, G, H, J, K, L, O, P, Q, R
3	Prioritize projects with greater watershed coverage.	K, L, M, N
4	Prioritize projects that achieve multiple benefits.	K, L, M, N, P
5	Practice and promote conservation efforts.	I, P, Q, R
6	Increase regional self-reliance and integrated water management across all levels of government.	A, B, C, D, E, F, G, H, K, L, N, O, P, Q, R
7	Achieve the co-equal goals for the Delta.	A, B, C, D, E, F, G, I, J, L, O, P, Q, R

8	Protect and restore important ecosystems.	I
9	Manage and prepare for dry periods.	A, B, C, D, E, F, G, K, L, O
10	Expand water storage capacity and improve groundwater management.	A, B, C, D, E, F, G, K, L, O, P, R
11	Provide safe water for all communities.	J, N
12	Increase flood protection.	C, D, E, H, K, L, N, O
13	Increase operational and regulatory efficiency.	A, B, C, D, E, F, G, K, L, O, P, Q, R
14	Identify sustainable and integrated financing opportunities.	K, M, N, P
1*	Include regional projects or programs.	K, L
2*	Effectively integrate water management programs and projects within a hydrologic region.	L, M, N
3*	Effectively resolve significant water-related conflicts within or between regions.	A, B, F, G, L, M, N
4*	Contribute to attainment of one or more of the objectives of the CALFED Bay-Delta Program as follows:	
	A. Water Quality	F, G, J
	B. Levee Integrity	A, B, G
	C. Water Supply Reliability	A, B, C, D, E, L
	D. Ecosystem Restoration	I
5*	Address critical water supply or water quality needs of DACs.	J, N
6*	Effectively integrate water management with land use planning.	F, H, I, J, K, L, M, N
7*	Effectively integrate water management with storm water planning.	H, K, M, N
8*	Effectively integrate water management with drought preparedness.	A, B, C, D, E, F, G, K, L
9*	Use and reuse water more effectively.	E, L
10*	Climate change response actions.	B, C, D, E, H, K, L, M, N
11*	Expand environmental stewardship.	I, K, L, M, N
12*	Practice integrated flood management.	C, D, E, H, K, L, N
13*	Protect surface water and groundwater quality.	B, C, D, E, G, J
14*	Improve Tribal water and natural resources.	K, N
15*	Ensure equitable distribution of benefits.	G, H, I, J, K, L, N

\*note that these preferences are from the 2014 Update

## 4.8 Resource Management Strategies

According to the California Water Plan Update 2013, a Resource Management Strategy (RMS) is defined as a technique, program, or policy that helps local agencies and governments manage their water and related resources. These strategies include both structural improvements, such as, conveyance enhancements or groundwater recharge facilities; and non-structural measures to implement program or policy solutions.

The Water Plan Update 2013 lists and describes 31 RMSs to be considered by an IRWM Group and RWMG in development of the IRWMP, as practically applicable, to diversify their water and general resource management portfolio. Each of the RMSs is addressed in this Plan and Table 4.3 indicates the consistency between the Objectives and those RMSs which were considered applicable to the Region. Included in the table are a description of each RMS, evaluation of the applicability to the Region, constraints on associated Objectives, and an assessment of the general climate change impacts from each strategy (see Section 13.0 for further discussion on the impacts of climate change on the Region). It is noted that RMSs not currently considered applicable to the Region will be periodically reviewed by the RWMG during future planning efforts. Most of the applicable RMSs are ongoing water management activities that are being practiced by the districts, communities, and environmental organizations in the Region.

**Table 4.3 IRWMP Resource Management Strategies**

Strategy	Applicable to Region	Applicability Assessment	Measurable Objectives	Objectives/Constraints	Climate Change Impacts
<b><i>Reduce Water Demand</i></b>					
Agricultural Water-Use Efficiency	X	California Senate Bill x7-7 (SBx7-7) requires agricultural water suppliers to prepare AWMPs and addresses a set of Efficient Water Management Practices (EWMPs) for regional water management and improved governance of irrigation water distribution.	A, B, C, K, L, M	Regional constraints include grower interest in technological and behavioral improvements, funding and cost-effectiveness, feasibility of converting to high-efficiency irrigation methods for certain crops and field configurations.	As climate change threatens to decrease available water supplies to the Region and create hotter and drier conditions unfavorable to growing certain crops the management of water-use for agricultural needs will become increasingly important.
Urban Water-Use Efficiency	X	SBx7-7 sets a goal of reducing per capita water by 20% by the year 2020. To meet this goal, increases to urban water-use efficiency through technological and behavioral improvements will become necessary. There are no large municipalities in the Region; however there are DACs in the region that implement water conservation measures.	A, B, C, J, K, L, M	Regional constraints are related to funding for DAC communities to implement feasible water conservation measures, such as, improvements to current water distribution networks, or for treatment and piping.	Climate change threatens to decrease available water supplies to the Region including those which are used for DAC community purposes. Drier conditions with increased daytime and nighttime temperatures means effective water management practices in populated areas will become a necessity.
<b><i>Improve Flood Management</i></b>					
Flood Management	X	Flood management is used to manage flood flows and to prepare for, respond to, and recover from flood conditions. Some hydrologic features, such as, the Kern River pose flood risks in the Region.	C, D, H, K	The RWMG may increase absorptive capacity. Constraints include funding and cost-effectiveness of enhancing or repairing flood control infrastructure, which is not controlled by the RWMG.	Climate change could increase the severity and intensity of flooding in the Region, meaning flood protection and management measures will need to be enhanced.



**Table 4.3 (Continued) IRWMP Resource Management Strategies**

Strategy	Applicable to Region	Applicability Assessment	Measurable Objectives	Objectives/Constraints	Climate Change Impacts
<i>Improve Operational Efficiency and Transfers</i>					
Conveyance (Delta)	X	A number of water users in the Region are SWP contractors, meaning water that is conveyed to their service area is diverted from the Sacramento-San Joaquin River Delta.	A, C, E, K, L	Constraints for managing water conveyed from the Delta are primarily regulatory pumping constraints leaving the Delta to the Region, as well as conveyance constraints for SWP deliveries into districts.	Climate change threatens to decrease water available from the Delta, thus decreasing the quantity of SWP deliveries to the Region. The decrease in deliveries means increased groundwater pumping to meet Regional demands.
Conveyance (Regional/Local)	X	Imported surface water and pumped groundwater in the Region are conveyed to areas of demand using conveyance infrastructure, such as, canals, pipelines, pumping plants. Conveyance facilities vary in size from small, localized distribution systems to larger-scale systems that deliver water within and across irrigation districts.	C, E, K, L	Conveyance facilities are largely restricted by the volume of water that can be delivered during flood releases or to meet peak summer demand. The acres and number of users who can receive supplemental surface water supplies to offset groundwater pumping is constrained to the delivery area of these facilities.	Climate change threatens to decrease the volume of water delivered to the Region, and cause greater variance in the availability of these limited supplies. Increased capacity for groundwater recharge will be necessary to deliver water during different times of year, when water is available, or to deliver higher volumes during shorter durations.
System Reoperation	X	Reoperation involves changes to operations and management of existing reservoirs and conveyance facilities to increase water related benefits. Reoperation changes considered feasible for the RWMG include irrigation districts altering operations to enhance water conveyance through interties between districts.	C, E, K, L	Constraints of altering operations and management for Participants or districts within the Region are largely based on legal obligations or water rights for users within the applicable service areas.	Changes in water demands and supplies due to climate change may force reoperation in the Region in order to adequately supply water users. Reoperation options may be re-evaluated during future planning processes.

**Table 4.3 (Continued) IRWMP Resource Management Strategies**

Strategy	Applicable to Region	Applicability Assessment	Measurable Objectives	Objectives/Constraints	Climate Change Impacts
<i>Improve Operational Efficiency and Transfers</i>					
Water Transfers	X	CWC defines water transfers as temporary or long-term changes in diversion, use, or purpose of water or water rights. Transfers are a common part of water management in the Region.	C, L	Water transfers are constrained by district regulations and policies, cost-effectiveness, and availability of conveyance capacity and the use of facilities to enable transfers.	Decreases in water supplies due to climate change may cause an increase in water or water rights transfers from those who have adequate supplies to those who do not.

**Table 4.3 (Continued) IRWMP Resource Management Strategies**

Strategy	Applicable to Region	Applicability Assessment	Measurable Objectives	Objectives/Constraints	Climate Change Impacts
<i>Increase Water Supply</i>					
Conjunctive Management and Groundwater Storage	X	Conjunctive use is the coordinated and planned management of both surface and groundwater resources in order to maximize their use. Since groundwater overdraft is a major concern in the Region, the RWMG actively facilitates conjunctive management and groundwater storage to alleviate issues with water supplies.	B, D, E, F, K, L	Conjunctive use includes several factors which must be considered, and monitored at a cost to regional participants. These include groundwater monitoring programs, recharge facility management, and groundwater use monitoring. Constraints include costs of constructing these facilities and management efforts.	As climate change is likely to decrease the amount of surface water available for import to the Region, it is realistic to assume a greater reliance on pumped groundwater to meet irrigation demands. Substantial efforts must be taken to encourage conjunctive management when supplemental water is available, to avoid or mitigate groundwater use. Further discussions and accounting for climate change impacts will be present in Groundwater Sustainability Plans for the Region.
Desalination (Brackish & Sea Water)		Desalination is the treatment of saline water to remove salts and make it available for municipal, agricultural, and environmental use. This process not only applies to seawater, but also on low-salinity (brackish) groundwater. Presently, salinity is a manageable in the region with a few saline water sources.	N/A	Some opportunities exist for desalination in the Region. The opportunities are limited to certain areas with brackish water and are not readily feasible. Desalination opportunities are being considered by the RWMG member districts and may become feasible in future planning efforts.	Salinity levels are higher on the west-side of the Region in the groundwater. If climate change decreases surface water availability, and salts continue to rise in the groundwater, desalination efforts will be needed in order to use the water for agricultural, municipal, and environmental purposes.

**Table 4.3 (Continued) IRWMP Resource Management Strategies**

Strategy	Applicable to Region	Applicability Assessment	Measurable Objectives	Objectives/Constraints	Climate Change Impacts
<i>Increase Water Supply</i>					
Precipitation Enhancement	X	Precipitation enhancement, known as ‘cloud seeding’, stimulates cloud formation to produce more precipitation than in natural conditions. This process is not a remedy for drought, but enhances deliveries of water to a Region in years of excess water supply.	C, K, L	North Kern WSD, a District in the Region, has participated in cloud seeding; however, the lack of steady water supplies and available funds has slowed the expansion of this program. More data are needed to assess effectiveness of cloud seeding operations.	Climate change will likely make water less available to the Region, meaning less will be available for precipitation enhancement efforts (cloud seeding).
Municipal Recycled Water	X	Recycled water can be used for many purposes depending on treatment procedures. Reuse requires RWQCB approval. The RWMG actively reuses municipal water for agricultural purposes for non-edible crop irrigation and industrial processes.	J, K	The use of recycled municipal water is limited due to high treatment costs and distribution, depending on use, regulatory issues, and more importantly public acceptance and the marketability of recycled water use.	As climate change threatens to decrease water supplies to the Region, the use of recycled water, for applicable uses, will become more important in order to conserve other water supplies.
Surface Storage (CALFED/State)	X	The CALFED Bay-Delta Program is focused on water issues in the Sacramento-San Joaquin River Delta (Delta). This RMS references improvements to surface storage in the Delta while working to improve conditions. Many water users in the Region rely on Delta water via the SWP or CVP, when available.	A, C, E, K, L	The CALFED Bay-Delta Program is influencing reliability of SWP water and coordinating environmental management. Given the Delta is outside the Region. Regulatory and court-ordered constraints regarding pumping and delivery of SWP water south of the Delta are largely out of the RWMG’s control.	Climate change threatens to decrease the amount of water available in regional and state-wide watersheds, including the amount of water available to pump and convey south of the Delta. To mitigate environmental concerns, less water will likely be pumped south via the SWP or CVP. As such, less surface water would be delivered to the districts.

**Table 4.3 (Continued) IRWMP Resource Management Strategies**

Strategy	Applicable to Region	Applicability Assessment	Measurable Objectives	Objectives/Constraints	Climate Change Impacts
<b><i>Increase Water Supply</i></b>					
Surface Storage (Regional/Local)	X	Surface storage references the use on or off-stream reservoirs to collect water for later release and use. Users of regional water supplies, such as, Kern River, have long relied on reservoirs like Isabella Reservoir, managed by USACE, to regulate timing of water deliveries to meet demand. Smaller localized reservoirs in the Region also exist.	C, E, K, L	The RWMG is not in control of the larger regional reservoirs, such as, Isabella Reservoir, managed by USACE used for surface storage, thus constraints on the amount of water released or allocated for regional use is factor of hydrologic year, water rights, and infrastructure constraints related to safety of dams.	The decreases or changes in timing of water available to watersheds may decrease and change the amount of water available in large surface storage reservoirs. Large reservoirs may be capable of capturing annual flow, even if it arrives at different time. Smaller localized reservoirs are important to enhance water conveyance, as they are used to regulate water to match supply with demand.
<b><i>Improve Water Quality</i></b>					
Drinking Water Treatment and Distribution	X	Providing a reliable supply of potable water for communities (DACs) in the Region is a goal of the IRWM Group. State and Federal drinking water standards require water treatment and distribution facilities to meet specific standards for water suppliers.	G, J, K	Communities (DACs) in the Region rely on groundwater to meet municipal demand. However, aging infrastructure and more stringent water quality standards have adversely affected the ability for DACs to provide reliably supplies.	The obligation for the IRWM Group to identify a reliable source of potable water will not be affected by climate change. The availability of the source of this water, however, may change as there may be a stronger reliance on groundwater for municipal and agricultural purposes due to decreases in surface supplies.

**Table 4.3 (Continued) IRWMP Resource Management Strategies**

Strategy	Applicable to Region	Applicability Assessment	Measurable Objectives	Objectives/Constraints	Climate Change Impacts
<i>Improve Water Quality</i>					
Groundwater Remediation/ Aquifer Remediation	X	Groundwater remediation includes the extracting of contaminated groundwater, treating it, and discharging it into water conveyance facilities or injecting it back into the underlying aquifer. Groundwater recharge in the Region is actively practiced; however, there is not a lot of groundwater remediation activity in the Region.	B, F, G, K	The Region is capable of recharging a significant amount of surface water into the groundwater using recharge ponds or through in-lieu recharge. However, remediation activity is very limited by the costs and supplies for treatment of the higher saline aquifer areas.	Groundwater is partially replenished by deep percolation during irrigation or conveyance seepage; both contribute a salt load into the aquifer making it less available over time for direct reuse. As climate change decreases water supplies for the Region, remediation efforts may need to be strengthened to recover some of this water within the Region.
Matching Water Quality to Use	X	The process of matching water quality to meet requirements for its intended beneficial use, agricultural, municipal, or environmental, is actively practiced in the Region through water quality monitoring efforts and use of treatment facilities.	G, J, K	Obstacles primarily include public acceptance for using lower quality water in any use, even if the standards are deemed applicable, and the distribution of water supplies of differing qualities around the Region.	As climate change threatens to decrease surface water supplies and create a greater reliance on groundwater, the process of matching water quality to meet intended uses will become more important to limit the costs of potentially unnecessary or avoidable treatment processes.
Pollution Prevention	X	Pollution prevention is separate, and arguably more cost-effective, than end-of-line treatment processes for potable or non-potable water. IRWM Group member participation in regulatory programs, for agricultural, municipal, or environment water purposes has helped to preserve good water quality in the Region.	G, I, J, K	Constraints to an active pollution prevention program include the funds needed to maintain a management program that involves water quality monitoring and to keep up with the changes to regulatory program requirements.	Pollution prevention in available water supply will become more important as water supplies become scarcer due to climate change. Keeping pollutants out of supplies helps to avoid loss of usable supplies in the Region and avoid unnecessary water treatment costs.

**Table 4.3 (Continued) IRWMP Resource Management Strategies**

Strategy	Applicable to Region	Applicability Assessment	Measurable Objectives	Objectives/Constraints	Climate Change Impacts
<i>Improve Water Quality</i>					
Salt and Salinity Management	X	Presently, salinity is a manageable issue in the Region. The IRWM Group interacts with the NRCS regarding on-farm salt management. The Irrigated Lands Regulatory Program (IRLP), of which the IRWM Group participants are members of, is also monitoring salts as an ongoing, regulatory effort in the Region.	G, K	Growers in the IRWM districts work directly with the NRCS with the objective to implement on-farm programs for salinity management. IRWM Group member districts are active in the IRLP, Central Valley Salts Coalition. The CV-SALTS program also helps with studies which inform planning efforts. Constraints include funding for the programs that monitor salts and provide on-farm support.	As climate change decreases surface water supplies available to the Region, efforts to assess salt content and salinity management will need to be strengthened to monitor the amount of salt loading in the Region and potentially, mitigate future costs for treatment.
Urban Runoff Management	X	Urban runoff generally includes both storm water and landscape irrigation water which may wash into storm drains. Both must be managed within communities (DACs) in the Region, to prevent damage to adjacent property or habitats.	J, K	Regional constrains include the extent of communities under jurisdiction of the RWMG, and the community connection with adjacent property. Many communities (DACs) do not have the funds or infrastructure to enact improvement for runoff management.	With changes in precipitation in the Region due to climate change, communities will likely have different and more variable storm water runoff to consider in operations. The potential damage to adjacent properties or habitats due to urban runoff would remain.

**Table 4.3 (Continued) IRWMP Resource Management Strategies**

Strategy	Applicable to Region	Applicability Assessment	Measurable Objectives	Objectives/Constraints	Climate Change Impacts
<i>Practice Resource Stewardship</i>					
Agricultural Land Stewardship	X	Stewardship is the conservation of natural resources and protection of the environment on agricultural lands. With most of the Region devoted to agricultural lands, land managers must work to protect the open space and traditional characteristics of rural communities and minimize urbanization on these lands.	K, M, N	Regional constraints include funding and incentivizing the continuation of agricultural areas through landowner incentives, regulatory barriers, and urbanization from communities within the Region and larger cities outside the Region, such as, the City of Bakersfield.	Agricultural land stewardship will become increasingly difficult as water supplies are less reliable in the Region due to climate change. It will likely be more of a challenge to continue farming with decreased surface water supplies, or having to compete with municipal users for available surface supplies.
Ecosystem Restoration	X	Ecosystem restoration references the restoration of aquatic, riparian, and floodplain areas as they are most directly affected by water and flood management actions. The IRWM Group recognizes the importance of restoration efforts to protect habitat and improve water quality for environmental resources.	I, K	Land costs in some areas and the feasibility of integrating restoration efforts into projects, programs, and daily management continues to be a constraint for ecosystem restoration efforts in the Region.	Due to the effects of climate change on water supplies in the Region, less water may be available for ecosystem restoration use for water-based habitats and the timing may change. As such, more pressure may be faced with competing priorities for environmental uses in the Region.
Forest Management		Forests are an important environmental resource leading to the production of water and timber, while providing a home for wildlife and native vegetation. Although management is important towards the sustainability of forest areas, there are no such classified areas in the Region.	N/A	No considerable opportunities for forest management in the Region.	Forest lands in surrounding areas will likely change, as climate change threatens to decrease water availability and cause unfavorable changes to temperatures and seasonal effects to wildlife and native vegetation.



**Table 4.3 (Continued) IRWMP Resource Management Strategies**

Strategy	Applicable to Region	Applicability Assessment	Measurable Objectives	Objectives/Constraints	Climate Change Impacts
<i>Practice Resource Stewardship</i>					
Land Use Planning and Management	X	Considerations of agriculture and urban land use in the Region while providing for the efficient use of water and preservation of water quality. The Safe Drinking Water Act (1996) requires public water systems to ensure sustainability of potable water and compliance with drinking water standards. As such, the IRWM Group considers this a priority for communities in the region.	C, H, I, K, L, N	The integration of land and water use planning is coordinated in the Region among various districts. The IRWM Group works with communities in the Region (DACs) and the districts to promote land use planning, however, differences in district responsibilities regarding local land and water use have constrained efforts.	The obligation for the IRWM Group to consider land use planning will stay the same regarding climate change. The source of Regional water may be affected, which may cause a stronger reliance on groundwater due to decreases in surface supplies. Planning efforts will need to work with communities in assuring land uses remain viable in the Region.
Recharge Area Protection	X	Protection of recharge areas is based on ensuring that areas suitable for recharge are protected from urban development and pollutants prevented from entering the groundwater. This is important to the IRWM Group as it is necessary for developing and maintaining groundwater recharge and banking projects.	C, D, F, K	As urbanization continues in the Region, high land values can make it difficult for the IRWM Group participants to protect recharge areas. However, it is uncertain if funding will inhibit the development of more recharge areas in the Region.	Recharge area protection will not likely be affected by climate change. However, changes in timing of supplies to the region would presumably mean the recharge areas would be used more to regulate supplies.
Sediment Management	X	Proper management of sediments and sediment transport provides multiple water benefits, environmental health, and economic stability. However, there is not much sediment and debris management in the Region.	K	The lack of localized sediment management efforts will inhibit the ability of the IRWM Group to monitor regional sediment and debris issues.	Climate change will not likely alter the practice of managing sediments and sediment transport (debris). However, efforts associated to this RMS may need to be diverted to other priorities due to climate change impacts on the Region.

**Table 4.3 (Continued) IRWMP Resource Management Strategies**

Strategy	Applicable to Region	Applicability Assessment	Measurable Objectives	Objectives/Constraints	Climate Change Impacts
<i>Practice Resource Stewardship</i>					
Watershed Management	X	Watershed management includes the process of evaluating, planning, managing, restoring, and organizing land and other resource uses within an area that has a common drainage point, such as, the Kern River and Poso Creek.	A, D, E, I, K, L	Many watershed management programs are implemented by non-governmental organizations like the KRWCA. Coordination with these organizations, while promoting water use in the Region, continues to be a constraint with these efforts.	Climate change is expected to change precipitation and flows in many of the State’s watersheds; including the most notable ones pertinent to the region, Kern River and Poso Creek. As such, local and regional water supplies will likely change in availability.
<i>People and Water</i>					
Economic Incentives	X	Economic incentives include financial assistance, water pricing, and water market policies intended to influence water management. Based on the extent of water users in the Region, economic incentives are prevalent but vary based on district policy.	K, L, N	The primary constraint for implementing economic incentives in the Region is funding, determining cost-effectiveness, and justifying the feasibility of financial assistance for specific cases.	Climate change effects will likely affect economic incentives, such as financial assistance for improving landowner and district water management, into incentives for mitigating the impacts of changes to water supplies in the Region.
Outreach and Engagement	X	The tools and practices by which water agencies allow public groups and individuals to contribute to water management through supporting activities and adoption of water-wise practices. As the complexity of water systems and conveyance has grown, the RWMG is committed to engaging with the public, in particular regional water users for improving water management.	J, K, L, M, N	The time, money, and employee resources needed to generate public awareness and continue engagement activities have constrained these efforts by the IRWM Group participants. As such, understanding of technological resources and utilizing outreach opportunities is a continuous practice of the IRWM Group.	The IRWM Group will disseminate information from climate change and environmental studies regarding the Poso Creek Region. Historical versus current, and expected, trends in climate and water data will need to be made aware to the public and landowners in the Region.

**Table 4.3 (Continued) IRWMP Resource Management Strategies**

Strategy	Applicable to Region	Applicability Assessment	Measurable Objectives	Objectives/Constraints	Climate Change Impacts
<i>People and Water</i>					
Water & Culture	X	Water and culture refers to the awareness of how cultural values, uses, and practices are affected by water management and how this information informs Regional policies and decisions. Since a vast majority of the Region is agricultural land, dependent on local and imported water supplies, the link between regional culture, landowners, and water management is very strong.	J, K, L, N	RWMG Participants, Stakeholders, and Interested Parties typically include landowners in the Region who are fully aware of the water management and planning efforts by the IRWM Group. For those who are not involved in the IRWMP, outreach and engagement efforts have been made a priority of the RWMG (see previous RMS).	There are some concerns regarding the culture of the Region and the acceptance of the effects of climate change and potential impacts on water. The IRWM Group will continue to make efforts to increase public awareness to the potential effects of climate change on the Region and on individual water users.
Water-Dependent Recreation		The public trust responsibility implies that local, State, and Federal agencies should manage the recreation and public access of lands and water resources within the Region. Other than the Kern National Wildlife Refuge, no major public recreational areas in the Region exist, however, some water resources and lands are devoted to recreational purposes of duck clubs.	N/A	There are practically little to no opportunities to promote or sustain water-dependent recreation in the Region. A few recreational water uses, associated with the duck clubs, are supplied through agreements for water supplies from CVP, conveyed through individual districts.	The few recreational water uses that are currently supplied with water may see changes in or elimination of supplies, as priorities are changed in the Region due to changes in overall deliveries from the effects of climate change.

Assessment of the impacts and benefits of each RMS to Regional resource management is covered in Section 6.3. Note that the connections between the Measurable Objectives and the RMSs are hinged on the connection with the RWMG’s Regional Goals, as shown and explained in Section 4.6.

## 4.9 Other Strategies

Other miscellaneous strategies were also listed in the Water Plan Update 2013 that may be considered by an IRWM Group during development of the IRWMP, as applicable. Table 4.4 describes some of these strategies and their compliance with the Measurable Objectives, if applicable. Although some of these strategies may not be currently applicable to the Region, they provide a basis for assessing future planning efforts by the IRWM Group and will be re-evaluated going forward.

**Table 4.4** IRWMP Miscellaneous Strategies

Strategy	Description	Applicable to Region	Measurable Objectives
Crop Idling for Water Transfers	Removal of lands from irrigation so water supplies can be transferred to other lands within a service area. Benefits include redistribution of water to higher priority areas and payment to water users who forego their allocated supplies. Loss of crop production, however, can have adverse social and economic impacts on the Region.	X	K, L
Dewvaporation or Atmospheric Pressure Desalination	Dewvaporation is the process of humidification-dehumidification desalination, which is the process of converting saline water to usable fresh water. Applicable to coastal regions and regions with salt increase concerns.		N/A
Fog Collection	Collection of fog for use in municipal water supplies. Applicable to coastal areas where fog events are more dense and frequent.		N/A
Irrigated Land Retirement	Permanent removal of farmland so water supplies can be transferred to other lands within a service area, or taking unproductive land out of production. ‘Retired’ lands can be converted to other uses with low water demand, or to habitat lands. The strategy reduces water demands, however, may have impacts to neighboring lands or have adverse social and economic impacts on the Region.	X	C, K, L

**Table 4.4 (Continued) IRWMP Miscellaneous Strategies**

Strategy	Description	Applicable to Region	Measurable Objectives
Rainfed Agriculture	Practice of fulfilling crop consumptive use directly by regional rainfall. Applicable to regions where rainfall frequency, duration, and amount are more predictable and reliable.		N/A
Waterbag Transport/Storage Technology	Waterbag transport and storage technologies involve diverting water in areas with excess freshwater supplies, storing the water in large inflatable bladders, and towing them to coastal regions where the water is less available. This strategy is not currently used in California due to capital costs and permitting requirements.		N/A

Regarding climate change, there is the potential that water supplies will decrease along with a water demand increase in the Region and/or increased salinity buildup. This may result in a greater need to institute and incentivize crop idling procedures or land retirement. These practices may soften the social and economic impacts of reduced cropped acres in the Region due to changes in the climate. Assessment of the impacts and benefits of generalized strategies to Regional resource management is presented in Section 6.3.

#### **4.10 Stakeholder, Agency, and Public Involvement**

As mentioned elsewhere, RWMG Participants, Stakeholders, and Interested Parties have remained active in the efforts to develop and refine the Regional Goals and Measurable Objectives. Also, as explained in Section 4.3, an effort has been made to make sure these objectives meet the DWR planning requirements. The direct involvement, outreach, and planning efforts of the RWMG Participants, Stakeholders, and Interested Parties are presented in Section 11.3.

Recall that the planning hierarchy illustrated in Figure 4.1 was used to develop the Plan and assess implementation of various project and programs. As described in the preceding sections, the IRWM Group has used the Measurable Objectives as a means of connecting the Regional Goals and Vision and Mission statements to the Statewide Priorities, RMSs, and other strategies, thereby establishing the Measurable Objectives as a DWR- and RWMG-compliant list used to assess projects and programs. This planning structure, complementary to the aforementioned planning hierarchy, is shown in Figure 4.11.

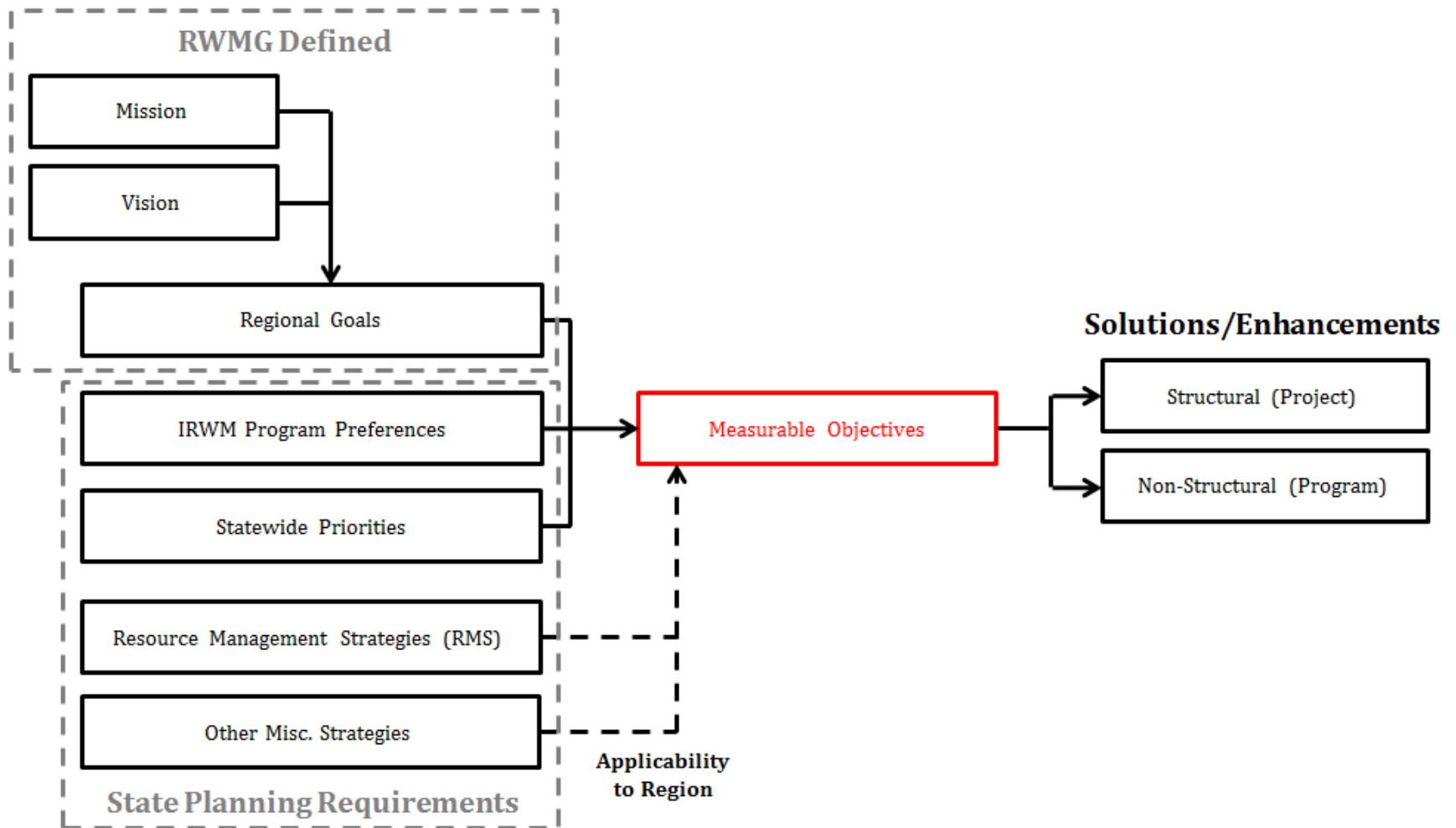

Figure 4.11 IRWMP Planning Structure.

## 5.0 Projects and Programs Review Process

In accordance with the IRWMP Proposition 1 Program Guidelines, this section addresses the ‘Project Review Process’ Plan Standard, which includes the requirements shown in the following table (along with identification of the specific subsection(s) where each requirement is addressed).

<b>Requirement</b>	<b>Plan Section(s)</b>
Procedure for submitting projects, reviewing projects, and communicating lists of selected projects.	5.1
Project contributions to plan objectives.	5.1, 5.2
Project related to Resource Management Strategies.	5.2
Project technical feasibility.	5.1
Specific benefits to DACs.	5.1, 5.4
Environmental justice considerations.	5.4
Project costs and financing.	5.3
Economic feasibility through economic analysis.	5.3
Project status.	5.5
Strategic implementation of plan and project merit.	5.1
Project proponents will have or adopt an IRWMP.	5.1
Projects will reduce dependency on Delta supplies.	5.4
Project’s contribution to climate change adaptation.	5.4
Contribution of project in reducing GHGs compared to project alternatives.	5.4
Specific benefits to critical water issues for Native American tribal communities.	5.5

The RWMG considers and reviews potential projects and programs for implementation following a relatively simple and flexible review process, which was originally presented in the 2007 IRWM Plan and the subsequent 2014 Update. The IRWM Group maintained then and still maintains an ‘open door’ policy with regard to project and program suggestions. In the 2007 IRWM Plan, selection of projects and programs emphasized the applicable Planning Objectives (principally, water supply reliability). A very similar emphasis continues in this Plan Update, with additional attention to adapting to climate change, reducing greenhouse gas (GHG) emissions, and providing benefits to critical water issues for Native American communities. Implementation of selected projects and programs depends on aligning their characteristics with appropriate funding opportunities, at least in the case of those requiring funding assistance to move forward. The review process has remained very similar to the original approach (i.e., “simple and flexible”) with an emphasis on conforming to the Regional Goals and Measurable Objectives from the 2014 Plan update, and as mentioned, now will further prioritize the Project’s contribution towards climate change adaptation and solving Native American water issues as part of the 2019 Plan update.

The RWMG follows relatively simple and flexible project and program review procedures to accomplishing the review process, including:

- Submission of a project/program description to the RWMG for consideration to be included in the IRWM Plan by using the Project Definition and Characterization Form (PDCF), which is included in Appendix G.
- Review of the submitted programs and projects to implement the IRWM Plan and vetting of the review at a public RWMG meeting, which is documented by RWMG Implementation Meeting Agenda and Minutes.
- Maintenance and dissemination of a list of selected programs and projects, which are included in Appendices A1 and A2.

Projects and programs can be submitted to the RWMG for consideration at any time using the PDCF, after which they are further developed and refined through discussions of the IRWMP Group. The RWMG maintains a project list, shown in Appendix A2, which is linked to a map of the Region for ease of reference, as shown in Figure 5.1. Both new and revised projects and programs are considered for review by the RWMG during periodic public meetings. Projects and programs that provide benefits primarily to DACs in the Region are reviewed first by the DAC Work Group and then presented to the RWMG for discussion, consideration, and approval for inclusion in the IRWMP project list during the public meetings. Additions or modification to the list of the projects and programs included within Appendix A2 of this Plan, list will be noted in the Annual Reports.

Since the RWMG formed in 2006, it is worth noting that the IRWMP Group has successfully completed approximately \$151 million in planning and project and program implementation activities, which has been the result of leveraging local monies with both State and Federal grant funding. A ‘Report Card’ has been compiled by the RWMG that identifies each of the accomplishments and a copy is included in Appendix A1. These accomplishments are the product of a RWMG review process which has been in place since 2006.

## **5.1 Identification and Submittal of Projects and Programs**

The IRWM Group routinely identifies possible projects and programs and submits them to the RWMG for consideration for inclusion in the IRWM Plan (referred to herein as Project Submissions). The 2014 Plan Update refined the project submittal process by modifying the project and program submittal to include use of the PDCF. This PDCF is revised and updated as part of this 2019 Plan Update to include climate change adaptation, evaluation of Project in reducing GHG and benefits to critical water issues for Native America tribal communities.

Projects and programs submitted, received, and reviewed by the RWMG subsequent to the latest version of the Plan will appear in the Annual Report and in subsequent planning documents, such as the next formalized IRWM Plan update.

New and revised Project Submissions are identified by a RWMG Participant, Stakeholder, or Interested Party, a PDCF completed, submitted, and then proposed to the RWMG for discussion



during periodic, public meetings. Project Submissions follow the PDCF; an example of the PDCF is provided in Appendix G.

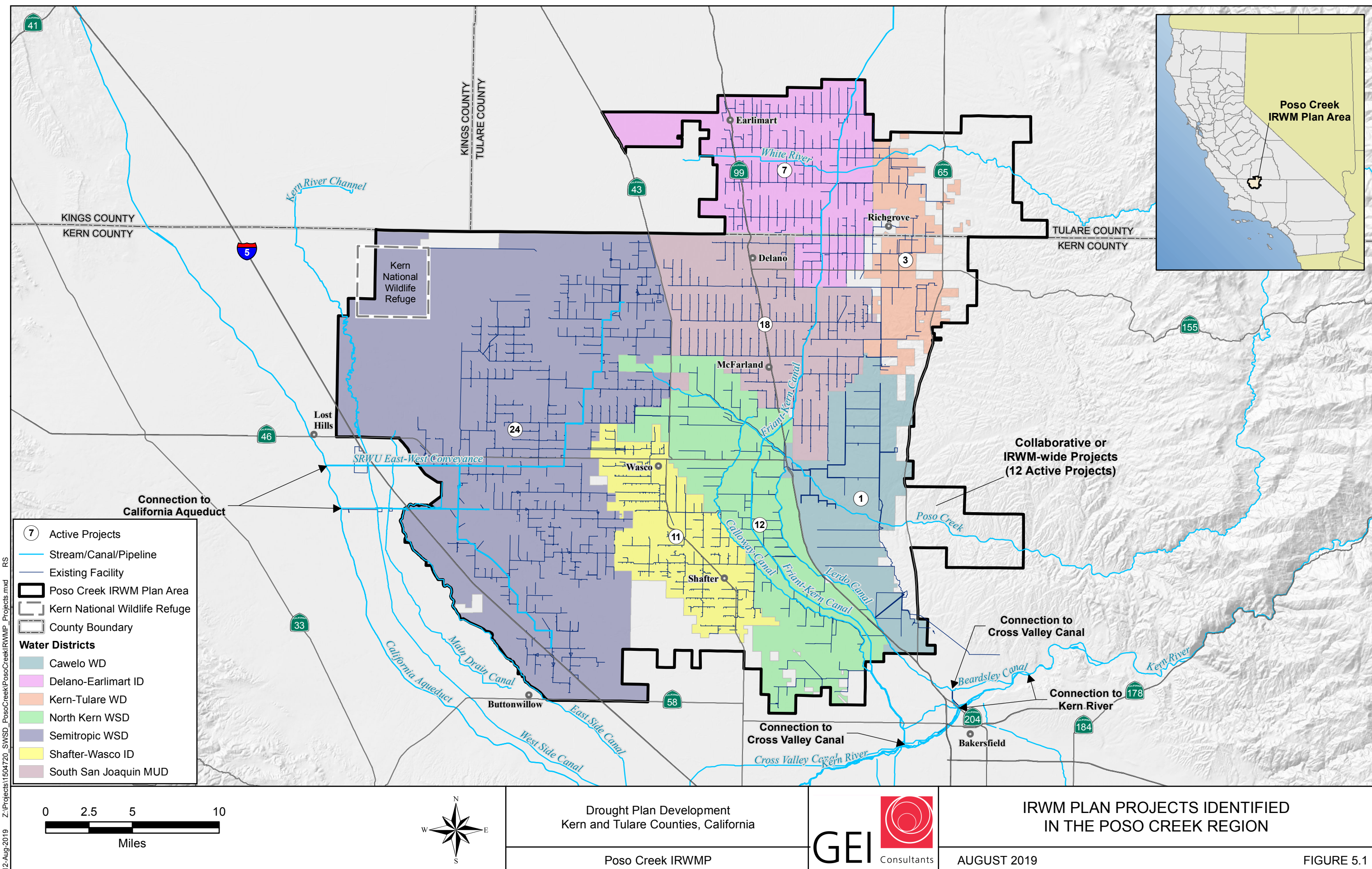

Figure 5.1 IRWM Plan Projects and Programs Identified in the Poso Creek Region

A PDCF is expected to address the following information:

- 1) Generalized project background, description and characteristics, including project type, sponsor, location, estimated cost, benefits, and impacts related to the IRWMP and Region;
- 2) Project/program regional operation related to dry, typical, and wet hydrologic years and conditions;
- 3) Goals and objectives of the project or program;
- 4) Consistency with IRWM Plan Measurable Objectives;
- 5) Contribution, if any, to climate change adaptation;
- 6) Contribution, if any, to reducing greenhouse gas (GHG) emissions, compared to project alternatives;
- 7) Specific benefits, if any, to critical water issues for Native American tribal communities.
- 8) Relationship with other projects in the IRWM Region;
- 9) Project impacts and benefits within the IRWMP;
- 10) Preliminary cost estimate;
- 11) Readiness to proceed; and
- 12) Implementation schedule;

The RWMG will disseminate a call for Project Submissions to the IRWM Group for consideration through e-mail and/or distribution at the public meetings. Following deliberation by the IRWM Group, project selection decisions by the RWMG are accomplished by a simple-majority vote at one of the aforementioned public meetings. The RWMG Participants utilize their experience managing water in the Region; their knowledge of ‘best resource management practices’, conformance with prior planning efforts, and multi-district regional benefits; and the advice of the Work Groups to assist in the approval and prioritization of submitted projects and programs.

The status of a project proponent’s plan adoption is determined based upon the degree to which a project 1) intends to feasibly address Resource Management Strategies, Measurable Objectives, and Primary Regional Goals with particular emphasis on climate change adaptation, greenhouse gas reduction, and contribution to solving crucial Native American tribal community and DAC water issues; 2) is technically feasible, determined by review from qualified engineers hired by the Poso Creek Group; 3) is economically feasible, determined by budgets from applicable funding opportunities; and 4) is practically feasible, determined based on the intended project’s status, schedule, and inclusion in an adopted IRWM.

The process for selecting and reviewing Project Submissions is shown in Figure 5.2. Regarding project and programs that are intended to primarily benefit DACs, or DACs that are

outside the Region boundary but are Interested Parties of the IRWM Group, the RWMG will rely on the recommendations of the DAC Work Group and the DAC Representative to assess potential benefits and provide support for project selection. As with any other project, DAC projects and programs must adhere to the IRWM Plan’s Measurable Objectives.

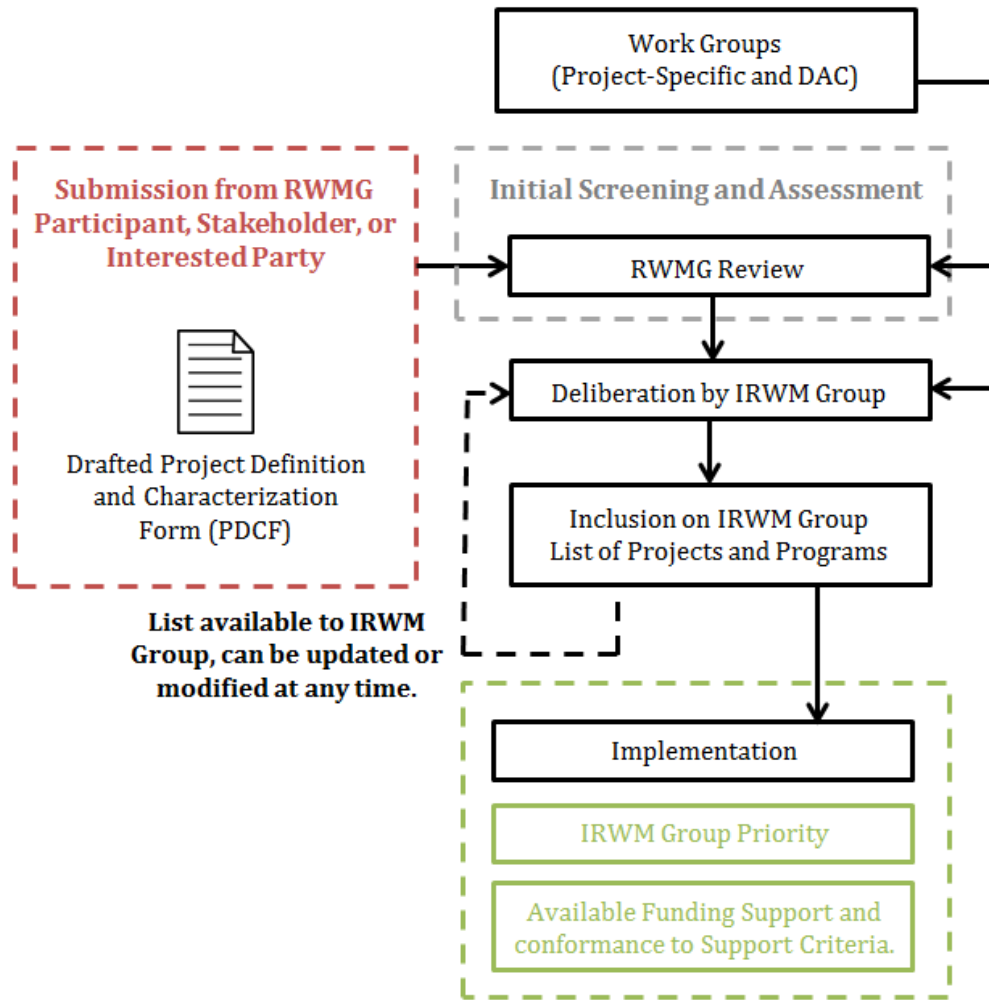

**Figure 5.2** Projects and Program Submission and Review Process

In the 2014 Plan Update, the RWMG categorized, submitted, and approved (for review) projects and programs using information similar to the 2007 plan, including:

- Categorize by structural “project” and non-structural “program”;
- Applicable Measurable Objectives (addressed), and
- Regional, Multi-district Benefits.

For the 2019 Plan Update, the RWMG has included a section detailing whether or not the Project contributes to climate change adaptation, reducing GHGs in comparison to project alternatives, and providing specific benefits to critical water issues for Native American tribal

communities. These have been added as additional benefits to preparing the region for the presumed effects of climate change and to address the pressing water issues in tribal communities.

PDCFs were updated to evaluate Project's contribution to climate change adaptation, reduce GHG emissions and address critical water issues for Native American tribal communities by checking if the Project -

- Considers the contribution of climate change on the region and consider if adaptations to the water management system are necessary;
- Considers changes in the amount, intensity, timing, quality and variability of runoff and recharge;
- Considers the contribution of the project in reducing GHG emissions as compared to project alternatives;
- Considers a project's ability to help the IRWM region reduce GHG emissions as new projects are implemented over the 20-year planning horizon; and
- Reduces energy consumption, especially the energy embedded in water use, and ultimately reduces GHG emissions.
- Considers specific benefits to critical water issues for Native American tribal communities

As part of the adoption of the 2019 IRWMP, an updated list of the projects and programs are included in Appendix A2. The accomplishments related to completed projects and implemented programs are indicated in the Report Card (Appendix A1).

## **5.2 Compliance with Measurable Objectives**

The 2019 IRWM Plan Objectives, as described in Section 4.5, were developed as a means of accomplishing the Regional Goals and providing direct support for the DWR Statewide Priorities and Water Plan RMSs. These Objectives provide the primary connection between regional projects and programs and other considerations in the planning structure, as identified in Figure 4.11. Submitted projects and programs are required to be compliant with these Objectives.

Project Submissions are required to provide a preliminary assessment of consistency with the Measurable Objectives, as identified in Part 4 of the submitted PDCF. In addition to this assessment, the RWMG will also compare each Project Submission to the list of Measurable Objectives directly using the resources provided by the proponent and their experience managing water and other resources in the Region. A Project Submission does not have to adhere to more than one Measurable Objective to be eligible for consideration by the RWMG; however, it is likely that a project and/or program that meets multiple objectives and provides regional benefits may be given greater consideration. It is noted that the RWMG will not approve a project and/or program for consideration unless there is a clear link, either quantitatively (preferred) or qualitatively,

between one or more of the Measurable Objectives and the potential benefits of project or program implementation.

Section 4.4 of the Plan also indicates and describes the differences between Regional Goals that have been designated as “Primary” (Goals 1 through 6) and those designated as “Secondary” (Goal7). The linkage between all Regional Goals and the Measurable Objectives is shown in Section 4.6, illustrating that the Objectives may meet one or more of the Regional Goals and vice versa. As stated, there is an overwhelming need within the Region to meet the Primary Regional Goals related to regional water supplies. Accordingly, projects and programs that adhere to these Primary Regional Goals will likely be given greater consideration. However, the RWMG actively looks to integrate Secondary Regional Goals, related to sustainability or environmental concerns in the Region, into projects or programs that meet one or more of the Primary Regional Goals.

It is noted that adherence to the Measurable Objectives implies adherence to the Statewide Program Preferences and RMSs as described in Sections 4.7 and 4.8, respectively. These, and other strategies, will be considered on a project and/or program basis based on the Measurable Objective identified. As with the other considerations, projects and/or programs that address multiple strategies and/or preferences through multiple objectives will likely be given more consideration during review.

### **5.3 Funding Opportunities and Economic Feasibility**

Since the list of regional projects and programs approved and maintained by the RWMG is subject to change with new and revised submissions, there is a need to prioritize the list when considering a specific grant funding opportunity. Generally speaking, “prioritization” is based on adherence to multiple Measurable Objectives or conformance to the Primary Regional Goals, and is subject to the needs of the entire IRWM Group as determined during the deliberation of projects and programs. Not all projects or programs on the list are prioritized; rather, certain projects or programs may be preferred, or make sense regionally to sequence in a certain order to expedite the realization of regional benefits, and therefore may be implemented earlier than others.

Project implementation has been accomplished through a mix of local and non-local funding opportunities that complement or match the local funding contribution. These funding opportunities have been from a variety of sources and programs, each with its own eligibility and selection criteria; however, to date, all have been managed under State (DWR) or Federal (USBR) authorities. The RWMG makes an effort to stay in touch with both federal and state agencies with potential funding opportunities, so as to be better prepared or positioned when funding opportunity announcements are actually issued. The IRWMP list of projects and programs is open to consideration from Stakeholders and Interested Parties, including DACs and Native American Tribes, and is discussed with the RWMG during the public meetings.

Once projects have been prioritized based on their intended fulfillment of Measurable Objectives and Primary Regional Goals, the list is further refined by assigned economic feasibility factors. Each project's economic feasibility factor is determined by the compatibility between the project's expected budget and the applicable funding opportunities available to the RWMG. More specifically, preferred projects and programs are deliberated within the IRWM Group based on their adherence to the eligibility and selection criteria for a specific funding opportunity. Similar deliberations and assessments are performed for other projects and programs on the IRWM Group's list, eventually resulting in a recommendation of the "best fit" for the given funding opportunity based on 1) the expected project budget, and 2) how qualified the project is for an available funding opportunity, both of which ultimately determine each project's economic feasibility factor. While formulating the grant proposal, the RWMG primarily relies on the assistance of Work Groups, including the DAC Work Group, before making the final selection of projects and programs best suited for a given funding opportunity.

Once the IRWM Group has reached a decision, which need not be unanimous, the RWMG Participants vote on whether to pursue the specific funding opportunity with the selected projects and programs. Once a majority vote by the RWMG is reached, the project or program 'Sponsor(s)' will be expected to collaborate to fund the preparation of the funding proposal, utilizing internal or external resources, such as a consulting firm. In practice, one district, agency, or entity will prepare the funding proposal, even if there is more than one sponsoring entity. This is done to comply with requirements of the funding opportunity (which typically are based on a single contracting entity), as well as for the sake of efficiency and expediency, given the short time frame that is typically available for proposal preparation. The RWMG has completed several collaborative grant proposals under their MOU and a cost-sharing agreement among the sponsoring entities.

Once economic feasibility for a project has been ascertained, it is considered along with the other project adoption criteria (see Section 5.1). Those projects which best fulfill each category and whose funding is secured through successful grant applications or related pursuits become top contenders for implementation.

#### **5.4 Contribution to Climate Change Adaptation**

With expected climate change, droughts are likely to occur more frequently. In the past, projects implemented by the RWMG have focused on bringing added surface water to the region to recharge groundwater in order to better manage and prepare for dry periods. Further, projects have focused on supporting system redundancy and reliability as well as better capture excess water during wet years to offset the effects of drought during dry periods.

- Climate change considerations, including the project's or program's impact on the Region's ability to cope with the impending impacts of a changing climate (as discussed

in Section 13); specifically, the potential reduction or mitigation of Greenhouse Gas (GHG) Emissions or air pollutants in the Region.

Project's contribution to climate change adaption:

- Include potential effects of climate change on the region and consider if adaptations to the water management system are necessary.
- Consider the contribution of the project to adapting to identified system vulnerabilities to climate change effects on the region.
- Consider changes in the amount, intensity, timing, quality and variability of runoff and recharge
- Consider the effects of SLR on water supply conditions and identify suitable adaptation measures

Contribution of project in reducing GHGs compared to project alternatives:

- Consider the contribution of the project in reducing GHG emissions as compared to project alternatives
- Consider a project's ability to help the IRWM region reduce GHG emissions as new projects are implemented over the 20-year planning horizon
- Reducing energy consumption, especially the energy embedded in water use, and ultimately reducing GHG emissions

## **5.5 Contribution to Addressing Native American Tribal Community Water Issues**

There are no known tribal communities in the Poso Creek IRWM region. If a community is identified, the RWMG will amend the Plan to include the community and any projects that address the needs of the community.

## **5.6 Other Considerations**

Although not formally addressed on the PDCF for Project Submission, a project or program Work Group is expected to review and address the following considerations and report applicable information to the IRWM Group during the periodic meetings, initial screening and assessment, and IRWM Group deliberation processes. If no Work Group is appointed for a specific project or program submission, then the submitting party may be asked to provide this information along with the PDCF.

- Potential impacts and/or benefits to DACs in the Region. Primarily the necessity of a project or program towards meeting the critical drinking water needs of a community, and



the opportunity to provide a solution that may not otherwise be accomplished due to local funding limitations.

- Potential impacts and/or benefits to environmental resources in the Region. In particular, the potential impacts on local flora and fauna, specifically, endangered species and local habitats.
- Potential impacts and/or benefits to the water supply reliability in the Region. For instance, the impacts or reduction in water supply from the Sacramento-San Joaquin River Delta for SWP supplies, and Sierra Nevada runoff for CVP and local supplies.
- Potential impacts and/or benefits to neighboring regions (IRWM Groups), including the ability to work jointly on multi-regional water management.

## **5.7 Maintenance of Project and Program List**

The list of the approved projects and programs is included as Appendix A2. Additions or modifications to the Project and Program list will be noted in the Annual Reports. The Annual Reports will be made available to all RWMG Participants, Stakeholders, and Interested Parties. Since the list may be updated or modified periodically, the RWMG public meeting Minutes will contain recommended additions or modification to the Project and Program List. The Annual Report will note changes to the projects and programs proposed by the IRWM Group. The Lead Agency, Semitropic, maintains and provides the resources necessary for compiling the list and, therefore, can be contacted to obtain the up-to-date list.

## 6.0 Impacts and Benefits

In accordance with the IRWMP Proposition 1 Program Guidelines, this section addresses the ‘Impact and Benefit’ Plan Standard, which includes the requirements shown in the following table (along with identification of the specific subsection(s) where each requirement is addressed).

Requirement	Plan Section(s)
Potential impacts and benefits of plan implementation with the IRWM region, between regions, with DAC/EJ concerns and Native American Tribal communities.	6.1, 6.3, 6.4, 6.5
When a more detailed project-specific impact and benefit analysis will occur (prior to implementation activities).	6.6
Impacts and benefits section of the plan as part of normal plan management activities.	6.2

Identified projects and programs, as defined in Section 5.0, are expected to provide certain benefits for, and will have specific impacts on, the Region and surrounding areas. This section addresses general benefits for the Region based on estimated improvements to regional water management through the applicable RMSs. Specific impacts and benefits to IRWM Stakeholders and DACs from implementation of the Plan are also discussed.

Identifying the impacts and benefits of implementing the Plan is important for several reasons, which have been outlined in the IRWMP Proposition 1 Program Guidelines. In particular, it helps to:

1. Identify and prioritize the Regional Goals and Measureable Objectives, per the applicable RMSs (see Section 4.8);
2. Recognize and identify adverse impacts in addition to the more obvious benefits realized when implementing projects and programs;
3. Establish a benchmark for evaluating IRWMP performance.

Evaluation of Plan performance and monitoring specifications, including monitoring of impacts and benefits, are described in Section 7.3. The assessment of Regional and Inter-Regional impacts and benefits is based on generalized assumptions and qualitative assessments; it is not meant to provide a quantitative assessment of exact water savings by the implementation of individual projects or programs. However, quantitative assessments are considered and will be addressed in more detail as a project and program moves into implementation.

## 6.1 General and Economic Benefits of Regional Water Management

The *Findings and Conclusions* from the 2007 IRWMP identified the Region’s primary issue as water supply quantity and reliability, regarding imported surface water supplies from local, State (SWP), and Federal (CVP) sources. At that time, the long-term average annual reduction in imported supplies delivered to districts and users within the Region was projected to be on the order of 100,000 acre-feet. The water supply concerns have largely worsened since 2007, with decreased reliability of SWP water, which has been the result of additional regulatory/court-ordered constraints on pumping from the Sacramento-San Joaquin River Delta. The 2014 and 2019 Plan Updates emphasize measures to mitigate the reduction in imported water supplies. Accordingly, most of the benefits and impacts are related to this emphasis.

As mentioned previously (reference Section 1.1), prior to forming the RWMG, each of the agricultural water districts managed their water supplies more or less independently of neighboring districts. With formation of the RWMG in 2006, the focus was broadened to the collective assets of the Region in order to enhance regional water supplies and improve regional water conveyance and conservation, all within the shared groundwater basin. Since that time, the Vision and Mission have developed and are addressed in Section 4.2. Under this umbrella, several of the projects and programs included in the 2007 IRWMP and 2014 Plan Update have been implemented in this 2019 Update. As described in the 2007 IRWMP and 2014 Plan Update, the key *benefits* to regional water management include:

- Development of long-term vision for regional water management, institutional agreements for operations between districts, and coordination regarding water quality issues;
- Improved regional water reliability and increased operational flexibility;
- Reduced potential for conflict and increased cooperation for management of water resources (supplies) across political boundaries;
- Implementation of goals and objectives that support economical and efficient use of water within the Region;
- Coordinated regional project and program development, and improved sequencing of project and program implementation;
- Established framework for sharing regional water management ideas and information;
- Shared cost for regional water planning; and
- Increased understanding of regional water quality issues.

Many of these benefits have been realized to some extent with the implementation efforts which have been ongoing since adoption of the 2007 IRWMP, as listed in Appendix A. Continuation of the efforts of the RWMG Participants, along with the involvement of Stakeholders and Interested Parties, is essential to maximizing these benefits. Conversely, the 2014 and this 2019 Plan Update both recognize the potential impacts that dissolution of the RWMG would have on the Region, assuming a return to more “independent” water management decisions, which could

result in more conflicts between districts. Under this scenario, it is reasonable to conclude that less cooperation would result in less surface water brought into the Region, which would exacerbate declining groundwater levels and increase the potential for land surface subsidence. The regional water management which has been practiced for several years now has evidenced the successful implementation of several key regional projects and programs. These “successes” can be expected to have the effect of strengthening the will of the RWMG to continue planning and implementation efforts in the Region, which will lead to further realization of the benefits listed above.

## 6.2 Plan Impacts and Benefits

In addition to the benefits listed in Section 6.1, implementation of the 2019 Plan Update will provide the following benefits beyond the 2007 IRWMP:

- Broader planning focuses; from water resource management to more generalized resource management. For example, the discussion of water supply and demand has been expanded to reflect environmental and climate change assessments. Unique to the 2019 Plan Update is an added emphasis on climate change adaptation and greenhouse gas (GHG) reduction as benefits for the Region. Additionally, as part of the Proposition 1 Program Guidelines, there is greater attention given to resolving water issues for Native American tribal communities, but there are no known tribal communities in the area. The IRWMP has actively investigated this and was able to determine there is no Native American tribal communities with the Plan area.
- Establishment of broader and more refined Regional Goals and Measurable Objectives (reference Sections 4.4 and 4.5).
- Greater emphasis on protection from drought conditions.
- Implementation of updated Resource Management Strategies (RMSs), including both structural and non-structural solutions (reference Section 4.8).
- Maintain compliance with State and Federal planning requirements, thereby increasing chances for obtaining funding assistance from State/Federal grant programs as a region, rather than as individual local agencies (districts).

While the 2007 IRWMP reflected the groundwater emphasis of the Proposition 50 Guidelines, the above-listed benefits illustrate the broader resource management assessment emphasis of the Proposition 1 2016 IRWM Program Guidelines, which is reflected in this 2019 Plan Update. The Plan Update also reflects the management efforts and accomplishments since adoption of the 2007 IRWMP and 2014 Plan Update. One consequence of not developing and implementing an updated IRWMP is the risk of 1) using potentially out-of-date information to inform planning decisions and regional priorities or 2) failing to prioritize issues whose importance has increased or requires further attention.

To maintain the most up-to-date Plan, the impacts and benefits assessment in the IRWMP will be periodically revised according to any revisions to the Proposition 1 IRWM Program Guidelines. Presently, assessment of impacts and benefits will comply with the following guidelines:

- Impacts and benefits will be reviewed and revised whenever the IRWMP is updated or DWR establishes new guidelines for this standard. It is expected that the IRWMP will be updated at least every 5 to 7 years.
- Impacts and benefits will be revised, as appropriate, to reflect anticipated or observed changes in the regional climate.
- Impacts and benefits will be revised to reflect lessons learned, or new impacts or benefits identified during implementation of local projects.

### **6.3 Resource Management Strategies**

As mentioned in Section 4.8, Resource Management Strategies (RMSs) are defined as a technique, program, or policy that helps local agencies and governments manage their water and related resources. There are 31 RMSs identified in the Water Plan Update 2013 for consideration by the RWMG, and each was assessed in Table 4.3 in terms of its connection to the Measurable Objectives and the whether they are applicable to the Region. All but three of these strategies were judged to be potentially applicable.

Table 6.1 addresses the screening level assessment of the impacts and benefits of the Resource Management Strategies with regard to the Region and to surrounding areas. The impacts and benefits of the potentially applicable strategies reflect the impacts and benefits of Plan implementation.

**Table 6.1** Screening-Level Assessment of Impacts and Benefits of IRWMP Resource Management Strategies

<b>Strategy</b>	<b>Regional Impacts</b>	<b>Regional Benefits</b>	<b>Surrounding Area Impacts</b>	<b>Surrounding Area Benefits</b>
<b><i>Reduce Water Demand</i></b>				
Agricultural Water-Use Efficiency	Impacts include reduced groundwater recharge from deep percolation and changes in operations for growers that may involve new hardware and maintenance.	Benefits include extended water supplies, including less water applied at farm-level and reduced water costs to users. May also decrease nutrients in deep percolation of applied water.	Interregional impacts from improvements to agricultural water-use efficiency include reduced recharge from deep percolation to aquifers that may be connected to neighboring areas.	Interregional benefits include the potential increase in water supply availability and delivery flexibility, as more efficient practices ensure less applied water and a reduction in deep percolation that may contain nutrients.
Urban Water-Use Efficiency	Impacts include changes in operations using existing municipal infrastructure by increased metering and management efforts, and potential losses in revenue with less water used.	Benefits include extended water supplies as less water is used for municipal purposes and reduced water and energy costs to regional communities.	Interregional impacts include reduced supplies to neighboring areas from improvements to urban water-use efficiency as less return flow water from watering landscape or wastewater effluent.	Interregional benefits include the potential increase in water supply availability, as more efficient practices ensure that less water will be applied and consumed.
<b><i>Improve Flood Management</i></b>				
Flood Management	Impacts include capital costs for projects and programs needed to manage flood flows in the Region, as well as ongoing maintenance costs, permitting costs, and emergency response planning.	Benefits include enhanced flood protection to the Region, including less flood-damage risk and the potential for recharging excess inflows for later uses.	Interregional impacts include limitations on urban and agricultural development in some high flood-risk areas, as well as increased flood management combined efforts between regions.	Interregional benefits include reduced downstream flood risk, thereby better managing excess upstream flows between regions. Will likely lead to decreased flood recovery costs due to less flood damage.
<b><i>Improve Operational Efficiency and Transfers</i></b>				
Conveyance (Delta)	Impacts include less supplemental (surface) water supplies and changes in operations using existing infrastructure and planning efforts.	Benefits include more effective conjunctive use operations. Also increased flexibility for deliveries.	Interregional impacts include changes in quantity and timing of deliveries from the Delta.	Interregional benefits include a positive environmental impact on the ecosystem of the Delta from an increased flexibility on demand for SWP supplies in the San Joaquin Valley.

**Table 6.1 (Continued)** Screening-Level Assessment of Impacts and Benefits of IRWMP Resource Management Strategies

Strategy	Regional Impacts	Regional Benefits	Surrounding Area Impacts	Surrounding Area Benefits
<b><i>Improve Operational Efficiency and Transfers</i></b>				
Conveyance (Regional/Local)	Impacts include less supplemental (surface) water supplies available and changes in operations using existing infrastructure and planning efforts.	Benefits include improved capacity to increase water reliability in the Region, as well as shared expenses for added flexibility for water delivery to complete transfers.	Interregional impacts include some changes in water reliability and salt content in water supplies, movement of salt between areas, and a need for increased management.	Interregional benefits include a positive impact on the groundwater system through increased flexibility for surface water deliveries.
System Reoperation	Impacts include the change of historical water supplies delivery and use in time.	Benefits include the potential enhancements to water conveyance and quality as a result of improving regional operations, including habitat considerations and improved flood protection.	Interregional impacts include greater effort for water management requirements and cooperation between regions to ensure reoperations work towards common resource management goals.	Interregional benefits include potential increase in water conveyance capacity, increase reliability of supply and flexibility for deliveries, and maintain quality of water for users.
Water Transfers	Impacts include a transfer of local water supplies to surrounding areas and other regions and the possible environmental impacts of moving water from a region.	Benefits include the efficient use of surface water supplies when available, and sources of revenue for regional water management efforts.	Interregional impacts include inflated water prices during transfer and exchange agreements, and the possible environmental impacts of moving water between regions.	Interregional benefits include agency cooperation and planning efforts that benefit multiple regions (from a water supplies standpoint).
<b><i>Increase Water Supply</i></b>				
Conjunctive Management and Groundwater Storage	Impacts include pumping to recover water in groundwater storage and increased data collection and monitoring costs for groundwater levels.	Benefits include being able to regulate surface supplies with varying hydrologic conditions while making effective use of the underlying groundwater basin. A successful conjunctive use strategy can help mitigate groundwater use and improve water supply reliability.	Interregional impacts include the energy used to recover water stored in groundwater bank, as well as changes to land use to allow for surface water deliveries and return of stored water.	Interregional benefits include greater water supply reliability and mitigation of curtailed supplies in particularly dry (drought) years. Effective conjunctive use management can be used to reduce flood flow in the Region and neighboring areas.

**Table 6.1 (Continued)** Screening-Level Assessment of Impacts and Benefits of IRWMP Resource Management Strategies

Strategy	Regional Impacts	Regional Benefits	Surrounding Area Impacts	Surrounding Area Benefits
<i><b>Increase Water Supply</b></i>				
Precipitation Enhancement	Impacts include altering the timing and distribution of water supplies in the Region. If water delivery is regulated by a storage reservoir, may not have any adverse impacts.	Benefits include an increase of water supply available for beneficial use in the Region.	Interregional impacts include a potential to increase water supply and the use of seeding agents in one particular area.	Interregional benefits include the potential to increase water supply, cloud build-up, and precipitation in surrounding areas to the Region.
Municipal Recycled Water	Impacts include increased costs for treatment and distribution operations, while complying with regulations and waste disposal guidelines. Process requires trained operators and secured facilities for operation.	Benefits include a reliable supply of water, regardless of hydrologic year, and the use of improved water quality (following treatment) for agricultural and environmental uses.	Interregional impacts include the energy use for operating treatment facilities or disposal of brine waste stream created by treatment process.	Interregional benefits include the potential for reducing groundwater pumping by use of recycled water, and the potential consolidation and joint-use of facilities, if feasible for the small communities in the Region.
Surface Storage (CALFED/State)	Impacts include the planning and permitting requirements, as well as the cost, for Delta Conveyance and reservoir water storage. If a failure of the major dam and reservoir (Isabella Dam) occurred, it would adversely affect the Region's ability to regulate available Kern River supplies.	Benefits include the ability to increase water supply reliability by absorbing surplus water into storage during "wet" periods to be available during "dry" periods, such as, during a drought.	Interregional impacts include reduced reliability and the potential failure of a large-scale dam and reservoir, such as Isabella Dam, leading to large-scale flooding in the downstream areas. The reductions in water reliability south of the Delta may also adversely affect local habitats.	Interregional benefits include the ability to effectively manage and distribute water sources conveyed south of the Delta or from Isabella Dam and Reservoir, leading to improved water resources management, and to the added recreational benefits a large reservoir provides, such as Lake Isabella.
Surface Storage (Regional/Local)	Impacts include the planning and permitting requirements, as well as the cost, for storage of water in a Regional reservoir, or in a local regulating reservoir.	Benefits include the ability to increase water supply reliability by absorbing surplus water into storage during "wet" periods to be available during "dry" periods, such as, during a drought.	Interregional impacts include the reduction of surplus water available for other areas.	Interregional benefits include the ability to use stored water supplies to meet transfer and exchange agreements with surrounding areas.



**Table 6.1 (Continued)** Screening-Level Assessment of Impacts and Benefits of IRWMP Resource Management Strategies

Strategy	Regional Impacts	Regional Benefits	Surrounding Area Impacts	Surrounding Area Benefits
<b><i>Improve Water Quality and Show Awareness of Climate Change Impacts</i></b>				
Drinking Water Treatment and Distribution	Impacts include increased costs for treatment and distribution operations, while adhering to drinking water regulations and waste water disposal guidelines. Processes require trained operators and secured, updated facilities to maintain operations.	Benefits include public health protection, regarding potable water distribution for community users, and maintaining regulatory compliance in the Region.	Interregional impacts include the energy use for operating treatment facilities or disposal of brine waste stream created by treatment process.	Interregional benefits include the treatment of water for the smaller communities around the Region; and the potential consolidation and joint use of facilities, if feasible, for the small communities in the Region, which may lessen the associated cost requirements.
Groundwater Remediation/ Aquifer Remediation	Impacts include the cost of remediation efforts and the potential issues with public perception for treating and injecting water back into the underlying (shared) aquifers.	Benefits include the avoided costs of purchasing additional water supplies for the Region; however, groundwater remediation activity is not prevalent in the Region.	Interregional impacts include the energy use or waste stream from remediation processes being introduced to the area.	Interregional benefits include addition of supply to offset water demand in Region, with the potential of more water being available for areas outside of the Region.
Matching Water Quality to Use	Impacts include the possible environmental impacts of using lesser quality water, as well as the infrastructure and conveyance costs of delivering and differentiating water of different qualities.	Benefits include making use of available water supplies in the most effective and economical manner while avoiding potentially unnecessary water treatment.	Interregional impacts include decreases in water supply quality, particularly in groundwater where water of lesser quality is recharged or percolated.	Interregional benefits include potential partnerships between the regions for delivering and differentiating water of different qualities, possibly minimizing the water delivery costs.
Pollution Prevention	Impacts include the continuous monitoring and management efforts needed to mitigate the potential impacts of pollution and GHGs. State and Federal regulations regarding pollution control will also impact the amount of water that is usable in the Region without being treated.	Benefits include improved water and air quality in the Region, resulting from mitigating the potential impacts of pollution and meeting State and Federal regulations.	Interregional impacts include challenging monitoring efforts for multiple Regions that receive water supply from same sources, such as SWP and CVP, and being able to distinguish between natural and introduced contaminants when working towards solutions.	Interregional benefits include being able to protect water sources for their intended beneficial use from the potential impacts of pollution, such as, maintaining water quality suitable for irrigation.

**Table 6.1 (Continued)** Screening-Level Assessment of Impacts and Benefits of IRWMP Resource Management Strategies

Strategy	Regional Impacts	Regional Benefits	Surrounding Area Impacts	Surrounding Area Benefits
<b><i>Improve Water Quality and Show Awareness of Climate Change Impacts</i></b>				
Salt and Salinity Management	Impacts include the movement of salts from one area in the Region to another, and the increased management efforts needed to monitor and reduce salinity concerns.	Benefits include increased longevity of irrigated lands in the Region while protecting beneficial water and soil use and postponing any potential issues with quality due to salinity content.	Interregional impacts include having to potentially retire lands due to inadequate water supplies of sufficient quality, as well as salt content build-up in the soils, and the resulting economic impacts due to land retirement.	Interregional benefits include regional collaboration and increased longevity of lands due to decreased levels of salts in water supplies and limiting saline water movement.
Urban Runoff Management	Impacts include the costs and infrastructure maintenance and enhancements necessary to manage urban runoff, thereby increasing the costs of urban development.	Benefits include the reduction in surface water pollution and minimized sedimentation problems. Urban runoff water is recharged in the Region to the groundwater basin.	Interregional impacts include possible groundwater contamination from recharged urban runoff water which is not sufficiently treated.	Interregional benefits include the water supply that is recharged into the groundwater and available to offset demand, allowing for more flexible water use within surrounding areas.
<b><i>Practice Resource Stewardship</i></b>				
Agricultural Land Stewardship	Impacts include the costs to implement efficient water management and resource practices by growers in the Region, likely affecting the costs of agricultural production.	Benefits include the implementation of efficient practices that increase the economic viability of agricultural lands.	Interregional impacts potentially include limiting the availability of land for conversion to urban areas to accommodate a growing population.	Interregional benefits include the preservation of agricultural and high-productivity lands.
Ecosystem Restoration	Impacts include increased costs for lands which are being restored, as well as the competing need for water supplies to restore these areas.	Benefits include the protection and enhancement of habitat resources in the Region.	Interregional impacts include opposition to restored lands and to environmental water uses for restoration efforts.	Interregional benefits include protection and enhancement of habitat resources in areas immediately surrounding the Region and providing natural water quality filtration areas.

**Table 6.1 (Continued)** Screening-Level Assessment of Impacts and Benefits of IRWMP Resource Management Strategies

Strategy	Regional Impacts	Regional Benefits	Surrounding Area Impacts	Surrounding Area Benefits
<i>Practice Resource Stewardship</i>				
Land Use Planning and Management	Impacts include the time and monetary resources required towards getting land and water use planners to coordinate on planning efforts.	Benefits include improved communication, planning, management support, and involvement among the planning groups.	Interregional impacts include overlapping efforts of various IRWMPs regarding land use planning, and the financial cost on different regions.	Interregional benefits include the potential for reduced conflicts between regions (IRWMPs) when planning new projects or programs.
Recharge Area Protection	Impacts include the change in land use and the monitoring efforts needed to sustain the recharge lands. The recharge areas may also provide a home to mosquitos.	Benefits include providing a sustainable water supply that is of usable quality; in particular, once water is recharged it reduces evaporative losses. Allows for flood protection in periods of surplus water in Region.	Interregional impacts include the diversion of surface water supplies, generally surplus water in “wet” periods, away from potential recharge uses in other regions.	Interregional benefits include recharge of usable quality water into the groundwater and mitigating the impacts of groundwater pumping and ground subsidence throughout the area. Recharge areas also provide a means for employing groundwater banking efforts used to store water for other regions.
Sediment Management	Impacts include the movement of sediments and debris from one area in the Region to another, and the increased management efforts needed to monitor and reduce sediment concerns.	Benefits include increased longevity of irrigated lands in the Region due to decreased levels of sediment and debris which may damage these lands.	Interregional impacts include having to potentially remove sediment and debris from lands and the resulting economic damages to the Region and surrounding areas.	Interregional benefits include longevity of lands due to decreased levels of sediment and debris.
Watershed Management	Impacts include the challenge of getting different IRWMPs and watershed management groups to work together towards a common purpose goal regarding watershed management.	Benefits include being able to communicate and offer solutions for watershed management that consider water and resource management concerns, environmental concerns, etc.	Interregional impacts include the potential overlapping of various IRWMP efforts towards watershed management, as natural watersheds do not necessarily follow IRWMP boundaries.	Interregional benefits include a broader impact towards watershed management for all pertinent groups. This can improve interregional collaboration and improve habitat conditions in most watersheds.

**Table 6.1 (Continued)** Screening-Level Assessment of Impacts and Benefits of IRWMP Resource Management Strategies

Strategy	Regional Impacts	Regional Benefits	Surrounding Area Impacts	Surrounding Area Benefits
<i>People and Water</i>				
Economic Incentives	Impacts include increased costs for RWMG Participants to deal with intermittent funding and IRWM program requirements. The application process is cumbersome for aspirants to complete.	Benefits include providing additional grant funding for infrastructure projects and programs in the Region. Economic incentives may lead to a decrease in water pricing, or increased economic stability in the Region.	Interregional impacts include increases in State and Federal debt due to grant funding incentives for the Region, or an inequity based on areas that receive funding.	Interregional benefits include increased absorptive capacity from project implementation in the Region allowing for water exchanges with other regions, as well as, completing the distribution of State and Federal grant funds across the State.
Outreach and Engagement	Impacts include time and monetary resources spent towards public and stakeholder outreach, including meetings and workshops for coordination efforts that require management needs and employee resources.	Benefits include improved communication and involvement among the public, stakeholders, and interested parties. Provides opportunities to support documentation of planning and management.	Interregional impacts include duplication of various IRWM efforts towards the dissemination of information regarding water management and other resource management concerns.	Interregional benefits include the potential for the IRWM Group and RWMG outreach to identify and communicate water and resource management concerns of the Region that apply to most regions in the State. Assuming most neighboring IRWMs are participating in similar efforts, this could help with public awareness.
Water & Culture	Impacts include the time and monetary resources spent towards public and stakeholder outreach, including meetings and workshops for coordination efforts that require management needs and employee resources.	Benefits include improved understanding in the public and stakeholders regarding water and resource management concerns in the Region.	Interregional impacts include duplication of various IRWM efforts towards the dissemination of information regarding water management and other culture information.	Interregional benefits include the potential for the IRWM Group and RWMG to identify and communicate water and resource management concerns of the Region that apply to most regions in the State. Assuming most neighboring IRWMs are participating in similar efforts, this could help with public awareness.

## 6.4 State and Federal Stakeholders

The RWMG has taken steps to engage with several State, Federal, and local agencies throughout IRWMP development and implementation, which has had the effect of influencing the IRWMP planning efforts in the Region. Additional information regarding the involvement of State, Federal, and local agencies and organizations in the RWMG and Plan development is presented in Section 11.0.

Implementation of the 2019 Plan Update is expected to have the following benefits to these agencies, beyond the general regional benefits listed in Section 6.1:

- Greater flexibility in regional water demand and reduced dependence on imported water;
- Greater regional drought preparedness;
- Reduced potential for conflict and litigation, and increased cooperation regarding water supply regulations;
- Increased opportunities for data collection, data sharing, and data management that are compatible with agency practices and databases;
- Increased focus on critical water issues for Native American tribal communities;
- Reduced greenhouse gas emissions;
- Greater climate change effect preparedness and mitigation;
- Shared development and use of hydrologic models and projections, and analytical tools for regional evaluation; and
- Continued compliance with agency planning requirements.

Most agencies, however, would not be significantly impacted by incomplete implementation of the IRWM Plan or by an inactive IRWM Group. The IRWMP planning efforts enhance, but do not replace, the agencies' planning efforts.

## 6.5 Stakeholders, Interested Parties, and Disadvantaged Communities

Stakeholders, Interested Parties, and Disadvantaged Communities (DACs) are directly or indirectly impacted by IRWMP development and implementation. Stakeholders include local, neighboring districts, state-wide organizations, and agricultural water and environmental advocacy groups, who do not generally participate as members of the RWMG. DACs in the Region are directly represented through a DAC workgroup (reference Section 11.3) and participate directly in regional planning and management efforts. The RWMG has made an effort to include the Stakeholders, Interested Parties, and DACs in regional planning and management efforts and, as a result, has tailored some of the suggested projects and programs to provide direct benefits to these groups.

Implementation of the 2019 IRWMP is expected to have the following benefits to the Stakeholders, Interested Parties, and DACs, beyond the general regional benefits listed in Section 6.1:

- Increased interaction and discussion regarding water management issues, concerns, and priorities. Provides a direct opportunity for specialized workgroups to address concerns and influence resource management in the Region.
- Improved direct support for specialized workgroups and DACs, through focused projects and programs that are part of IRWMP development and implementation.
- Increased opportunities for regional enhancement through projects and programs, since IRWMP Participants, Stakeholders, and Interested Parties can submit projects and programs through the IRWMP to be considered for inclusion in grant-funding proposals.

Specialized Work Groups are not expected to be severely impacted by incomplete or inactive IRWMP implementation, besides losing the opportunity to address concerns and influence resource management on a regional scale. DACs, in particular, would presumably lose out on necessary support for specialized projects and programs that would otherwise be unfeasible for these communities to implement on their own.

While providing benefits, implementation of the IRWMP has the potential to impact environmentally-sensitive areas or communities where new projects or programs would be implemented. If such impacts can be reasonably anticipated, a review of the significance of the impacts will be conducted on a project and/or program basis prior to being approved by the RWMG.

## **6.6 Project and Program Specific Assessment**

Measures implemented through this IRWMP will help offset the impacts to surface water supply reliability and mitigate groundwater pumping issues that are predicted for this Region. Review considerations for each project and program proposed, by the RWMG, are described in Section 5.1, including assessments of regional impacts and benefits for each measure. At a minimum, the assessment of benefits and impacts on a per-measure basis consider water resource management; economics and cost-effectiveness; environmental and climate change concerns; land use planning; and public benefit.

The RWMG's Measurable Objectives (reference Section 4.5) provide the basis for assessment of all projects and programs proposed for the Region. The group does not generally support projects or programs that will have potentially adverse impacts to the Region including environmental and economic, unless those impacts are mitigated and the potential benefits to resource and water management outweigh the impact.

## 7.0 Plan Performance, Monitoring, and Data Management

In accordance with the IRWMP Proposition 1 Program Guidelines, this section addresses the ‘Plan Performance and Monitoring’ and ‘Data Management’ Plan Standards, which includes the requirements shown in the following table (along with identification of the specific subsection(s) where each requirement is addressed).

<b>Requirement</b>	<b>Plan Section(s)</b>
Performance measures and monitoring methods to ensure that IRWM objectives are met.	7.1
Methodology that the RWMG will use to oversee and evaluate implementation of projects.	7.2, 7.3
Project compliance with all applicable rules, laws, and permit requirements.	7.3
Promote adaptive management as awareness of the effects of climate change, updated information, and new tools become available, and adjust IRWM plans accordingly.	7.3
Describe data needs within the region.	7.4
Describe typical data collection techniques.	7.4
Describe stakeholder contributions of data.	7.4
Describe entity responsible for maintaining data.	7.4
Describe QA/QC measures.	7.4
Describe process for sharing data collected for IRWMP implementation.	7.5
Describe how a Data Management System supports the efforts to share collected data.	7.5
Outline of how data will remain compatible with the State databases.	7.5

The stated intent of the Plan Performance and Monitoring standard is to ensure that the RWMG is efficiently making progress towards meeting the Measurable Objectives set forth in the Plan, implementing the projects and programs listed in the Plan, and that the implementation of each project and program is monitored to comply with all applicable rules, laws, and permit requirements. The following subsections address each of these considerations. In addition, the last two subsections address data needs, collection, management, and sharing.

### 7.1 IRWM Measurable Objectives

The IRWM Measurable Objectives are set forth in Section 4.5, along with measurement metrics as described in Table 4.1. These metrics include both quantitative and qualitative measurements and relates each metric to one or more of the Objectives. In many cases, a given metric supports several Objectives. By use of these metrics, progress in meeting the IRWMP objectives will be evaluated. Recall that projects and/or programs identified in the Plan are required to meet at least one of the Plan’s Objectives (reference Section 5.2). Accordingly, as

projects and programs are proposed, one or more of the IRWMP Objectives are identified and linked to the specific project during preparation and submittal of a PDCF (reference Appendix G) to the RWMG.

## **7.2 Implementation of IRWM Projects and Programs**

The IRWM Group has successfully implemented projects and programs since formation of the 2007 IRWMP and 2014 Plan Update, and the RWMG has developed a “Report Card” (reference Appendix A1) that captures the planning and implementation activity since then. The RWMG intends to update the Report Card annually for tracking progress with regard to project/program implementation. Beyond the Report Card, a list of project and program submissions that are ‘ready’ for implementation will be maintained by the RWMG and will be included in an Annual Report, prepared under the direction of the IRWM Lead Agency (shown in Appendix A2). The Annual Report will also include documentation of the RWMG’s progress towards meeting the Regional Goals and Objectives through project/program implementation.

In addition to the “formal” tracking procedures described above, the RWMG reports progress on planning and implementation activity at IRWM Group meetings, which are open to the public (Interested Parties). The IRWM Lead Agency prepares meeting agendas and minutes which include a report on each implementation activity performed or discussed, and a report from each active Work Group regarding project and program submissions. As projects and/or programs are selected and subsequently implemented, the progress of each project towards accomplishing a defined set of measurement metrics is reported at the IRWM Group meetings.

## **7.3 Project and Program Specific Monitoring**

Each project/program submission has a “Sponsor”, who is the implementing agency, organization, or individual that is identified in the PDCF for the project/program. The Sponsor, has the primary responsibility for development of the project- and program-specific monitoring plan and is responsible for implementing the monitoring plan during project construction (in the case of a structural project) and during project operations. In general, a monitoring plan would not be prepared until a project/program is selected by the RWMG. The Sponsor will be required to prepare a preliminary project- and program-specific monitoring plan prior to inclusion in a proposal for funding assistance. In this regard, DWR has provided the following guidance for the contents of a project-specific monitoring plan (reference the Prop. 1 IRWM Guidelines):

- 1) A clear and concise table describing what is being monitored (quantitatively or qualitatively) for each project. Examples include monitoring for depth to groundwater, volume of flow through a new conveyance facility or intertie, or increased absorptive capacity;



- 2) Measures to remedy or react to problems encountered during monitoring;
- 3) Location and frequency of monitoring;
- 4) Monitoring protocols/methodologies, including who will perform the monitoring;
- 5) Procedures or a Data Management System (DMS) to keep track of what is monitored and identification of who will retain the collected data. The monitoring plan will need to indicate if the collected data are appropriate for inclusion in statewide databases; and
- 6) A procedure to ensure the monitoring schedule is maintained and that adequate resources (including funding) are available to maintain monitoring of the project throughout the scheduled monitoring timeframe.

The above should be considered guidelines, inasmuch as each project is unique and may require either more or less detail. Once funded, any preliminary designs or preliminary environmental compliance documents are finalized, which allows the preliminary monitoring plan to be finalized as well. At this point, all applicable rules, laws, and permit requirements that need to be followed prior to and during project implementation are identified so that full compliance can be ensured, as required by Proposition 1 2016 Guidelines.

As each project is developed, an environmental compliance document is prepared under the California Environmental Quality Act (CEQA) and/or the National Environmental Policy Act (NEPA) guidelines. While project Sponsors are expected to provide the RWMG with progress reports and project completion reports, the ultimate responsibility for implementation of the monitoring plan rests with the Sponsor. For example, as a structural project moves into the construction phase, the Sponsor will cause to be prepared contracting documents that contain any applicable provisions in the monitoring plan to ensure that contractors follow applicable rules, laws, and permit requirements during construction.

Regarding any “lessons learned” from project- and program- specific monitoring efforts, the project Sponsor is expected to communicate these to the RWMG, preferably in writing. The RWMG recognizes that information can be gained from the project-specific monitoring to improve the RWMG’s ability to implement future projects in the Plan. For example, as newly constructed water conveyance interties are operated in the Region, water delivery and operation information is collected to support the applicable performance measures. Water delivery information is reported to the funding agency as part of required documentation of the performance of the improvement. Performance information is shared with the RWMG who can then utilize the information when considering future projects in updated IRWM Plans or reporting documents. Similarly, whether project-specific or more generally related to water use in the Region, to accommodate updated information, newly developed tools, and increasing awareness of the effects of climate change, the Region will adapt their IRWM to reflect these revisions.

## 7.4 Data Collection and Management

The stated purposes for the IRWM Data Management Standard are to ensure efficient use of available data for the Region; stakeholder access to the data; and effective integration into existing State databases as needed. This section clarifies how data is collected, validated, and shared in the Region. As mandated by 2016 Proposition 1 Guidelines, common protocols are in place to gather data in a consistent manner, and data and information sharing processes have been established to assist stakeholders in their local or regional efforts. In this context, “data” refers primarily to the periodic “measurement” of climate parameters, water deliveries, groundwater pumping, spreading, groundwater levels, and water quality. Land use surveys are also included, inasmuch as they involve a periodic assessment of the acreage of each of several categories of land use and, in the case of agriculture, the acreage of each of several crop types. These data needs are listed in Table 7.1 below, along with the entities making the measurements, which are identified in the table as “primary” data collectors. Updates to the data collection methods and needs for members of the IRWM Group, when they occur, will be reflected in future updates and in the Region’s corresponding GSPs.

**Table 7.1** Data Needs, Collection, and Management List

Data Type	Data Needs	Data Collection		DMS <sup>1</sup>
		Primary	Secondary	
Hydrology	Kern River Runoff Index	City of Bakersfield	KCWA	KCWA: Annual Water Supply Report
	CVP Allocations	USBR		
	SWP Allocations	DWR	KCWA	KCWA: Annual Water Supply Report
	Poso Creek Discharge	Cawelo WD		
Climate	Rainfall	DWR-CIMIS <sup>2</sup> , NWS, Kern County, USDA	KCWA	KCWA: Annual Water Supply Report, DWR: CIMIS Web-data, NWS Web-data
	Temperature	DWR-CIMIS <sup>2</sup> , NWS		CIMIS Web-data, NWS Web-data
	Pan Evaporation	DWR-CIMIS <sup>2</sup> , USDA	KCWA	KCWA: Annual Water Supply Report, DWR: CIMIS Web-data
	Evapo-transpiration (ET <sub>o</sub> )	DWR-CIMIS		CIMIS Web-data
Land Use	Districts, Kern County Agricultural Commissioner, DWR, FMMP, ITRC <sup>3</sup> , Land IQ	KCWA, USBR	MS Excel, Geographic Spatial Data (GIS) <sup>4</sup>	

\* See List of Acronyms for specific data sources and references.

<sup>1</sup> Data Management System (DMS).

<sup>2</sup> California Irrigation Management Information System (CIMIS) active stations are located in the Region, including Stations No. 5 (Shafter), No. 31 (McFarland/Kern Farms), No. 54 (Blackwells Corner), and No. 182 (Delano).

<sup>3</sup> Irrigation Training and Research Center (ITRC).

<sup>4</sup> Historically, individual districts used spreadsheets (e.g., MS Excel); however, the Kern County Agricultural Commissioner, DWR, and California Farmland Mapping and Monitoring Program (FMMP) have recently converted land use information into GIS-based files.

**Table 7.1 (Continued) Data Needs, Collection, and Management List**

Data Type	Data Needs	Data Collection		DMS <sup>1</sup>
		Primary	Secondary	
Surface Water Deliveries to Region	Kern River	City of Bakersfield	KCWA	KCWA: Annual Water Supply Report
	CVP (Friant-Kern)	USBR, FWA	KCWA	KCWA: Annual Water Supply Report
	SWP (California Aqueduct)	KCWA		KCWA: Annual Water Supply Report
District Water Deliveries (to landowners)		Districts		WIMIS, STORM, and MS Excel <sup>2</sup>
District Water Deliveries (to Spreading Ponds/Recharge)		Districts		MS Excel <sup>2</sup>
District Groundwater Pumping		Districts		MS Excel <sup>2</sup>
M&I Water Deliveries		Cities, Community Service District	KCWA	UWMPs <sup>3</sup> , KCWA: Annual Water Supply Report
Groundwater Levels		Districts, DWR, KCWA	DWR, DWR-CASGEM, KCWA, USBR	DWR: Water Data Library (online) <sup>4</sup> , KCWA: Groundwater Data Manager (MS Access) <sup>5</sup>
Water Quality	CVP Surface Water	USBR	FWA	
	SWP Surface Water	DWR		DWR: Water Data Library (online)
	Groundwater	Districts, KCWA	Kern County, KCWA, KRCWA	KCWA: Groundwater Data Manager (MS Access) <sup>6</sup>

\* See List of Acronyms for specific data sources and references.

<sup>1</sup> Data Management System (DMS).

<sup>2</sup> In general, individual districts use spreadsheets (e.g., MS Excel) for data management.

<sup>3</sup> UWMPs are updated every five years and provide the actual deliveries for the five-year period, as well as projected deliveries going forward.

<sup>4</sup> In addition to measurements, hydrographs can be downloaded from the DWR's website.

<sup>5</sup> KCWA prepares annual contour maps for depth to groundwater and for groundwater elevations. This data can be queried for the Region and write the data to MS Access or MS Excel.

<sup>6</sup> KCWA can query data for the Region and write data to MS Access or MS Excel.

In addition to the local water districts and irrigation districts, the primary data collectors include other local, State, and federal agencies. The local water districts and irrigation districts are the stakeholders which contribute the most significant body of primary data, which includes the following:

- Volume of district water delivered to farms.
- Volume of groundwater pumped from district-owned and –operated wells.
- Volume of water delivered to spreading ponds for groundwater recharge.
- Depth to groundwater at individual deep wells.
- Water quality reports for groundwater samples.
- Crop surveys.

With regard to data collection techniques, flowmeters are the basis for most measurements of water volume. Protocols for the measurement of depth to groundwater and for collecting water samples are set forth in the Groundwater Management Plans that have been adopted by each of the districts. Crop surveys are typically conducted through a combination of inspection of aerial photographs and field inspection, with acreages based on the estimated fraction of a land section, Assessor’s parcel acreage, and/or measurements based on aerial photographs.

These data have been collected and managed within the Region for decades. Data management systems vary from simple spreadsheets to more powerful and/or larger database software applications. As a generalization, more frequent measurements generate more data, which tends to favor database software, such as Microsoft Access. Measurement frequency varies from “daily” in the case of climate and most measurements of water volume, to “annual” in the case of land use surveys. In addition to the primary data collectors, there are agencies which collect and “house” data from primary sources, which are identified in Table 7.1 as “secondary” data collectors.

As indicated in Table 7.1, one of the most significant secondary sources of data for the Region is the Kern County Water Agency (KCWA). Formed in the 1960s, KCWA has been preparing an annual water supply report since the 1970s. While this report covers a larger area, the data are presented in a manner which allows data relevant to the Region to be identified. This report is made available to the public and is an important means of sharing data. In addition to this report, KCWA maintains a comprehensive groundwater database, which houses both water level and water quality data throughout the San Joaquin Valley portion of Kern County. This database is an MS Access application which can be queried (by KCWA staff) to yield all data relevant to the Region. The water level database includes measurements by KCWA and DWR staffs, as well as measurements by individual water districts which are supplied to KCWA.

So long as KCWA continues its historical data management role, reliance will continue to be placed on KCWA for these data. Most of the remaining data consist of the district-level water operations data which are collected and maintained by each of the water districts and irrigation

districts in the Region. Water operations data QA/QC begins with following established data collection protocols and continues by reconciling or otherwise balancing all water supplies with all water uses.

In the fall of 2013, the Central Valley Regional Water Quality Control Board (CVRWQCB) adopted a General Order which required monitoring of the quality of groundwater under its Irrigated Lands Regulatory Program. The Kern River Watershed Coalition Authority (KRWCA) and the broader San Joaquin Valley Water Quality Coalition have been responsible for compliance with these new monitoring requirements on behalf of their members. Going forward, the KRWCA will likely be a significant clearinghouse for groundwater quality data.

In addition to the QA/QC which occurs at the primary source by following established data collection protocols, data which are entered into KCWA's database are also subject to QA/QC measures related to data entry. With regard to water levels, KCWA uses DWR's system of carrying any field-level qualifications into the database, such as "well pumping nearby", etc. To some extent, the final level of QA/QC for water level data occurs when the data are charted over time and/or compared to measurements at adjacent wells. In this manner, questionable measurements are identified and flagged. Regarding water quality, QA/QC at the database level is much improved with advent of moving these data electronically from the testing/reporting laboratory into the database.

## **7.5 Data Sharing and Compatibility with Agency Databases**

As previously mentioned, to a very large extent, most of the necessary data collection and management has been ongoing for decades, and the KCWA has been the single largest clearinghouse for data at the regional level. With regard to data sharing, recall that KCWA prepares and makes available an annual water supply report which presents annual data and, in some cases, time series data. In addition to tables, the reports include many charts and figures to better communicate the data. For many years, these annual reports were distributed in a hard copy format; however, in recent years, they have been released in PDF file-format, which will make distribution of these reports both easier and broader. As for KCWA's groundwater database, it is understood that they have cooperated with DWR for many years in sharing water level data, and DWR's water level database is available on their *Water Data Library* website. In addition, the recently developed CASGEM program makes groundwater level data available, and several wells within the Region are included in that program, which are monitored by the individual water districts and irrigation districts within the Region.

While KCWA does not house the intra-district water operations data for the water districts and irrigation districts in the Region, Agricultural Water Management Plans and federal Water Conservation Plans provide vehicles for presenting and sharing much of these data. Each of the

water districts and irrigation districts in the Region has prepared or is preparing one of these plans, which are periodically updated.

Since most of the necessary data collection and management has been in place for some time, there has not been a compelling need to add another “layer”. Rather, the RWMG intends to create a “roadmap” to the sources of data to facilitate data sharing and will consider establishing an on-line library of selected reports. Table 7.1 effectively provides a “roadmap”. With that said, the time may come when there is a clear and demonstrated need to do more; accordingly, this is a topic which will be revisited periodically with the IRWM Group. The RWMG will facilitate data requests by providing direction to the best source of the requested data.

As mentioned in Section 7.1, the RWMG also maintains a list of proposed or accepted projects and programs, and data collection is maintained by the Project Sponsor, both at the feasibility level and upon implementation. To the extent that grant funding is involved, Project-level data are typically presented in a grant proposal at the feasibility stage, while performance data are presented in satisfaction of grant reporting requirements following implementation.

With regard to compatibility with State databases, KCWA presently cooperates with DWR with regard to groundwater level data; individual districts are participating in the CASGEM program; and Agricultural Water Management Plans, Groundwater Management Plans, and Urban Water Management Plans have been prepared by most districts according to State guidelines. Finally, it is anticipated that the KRWCA will be coordinating the development of its data management system with the CVRWQCB and will therefore meet State requirements.

## 8.0 Funding Opportunities

In accordance with the IRWMP Proposition 1 Program Guidelines, this section addresses the ‘Finance’ Plan Standard, which includes the requirements shown in the following table (along with identification of the specific subsection(s) where each requirement is addressed).

<b>Requirement</b>	<b>Plan Section(s)</b>
Plan for implementation and financing of projects and programs.	8.1, 8.2, 8.3
Known and possible funding sources, programs, and grant opportunities for the development and ongoing funding of the IRWMP.	8.1, 8.2
Funding mechanisms, including water enterprise funds, rate structures, and private financing options, for projects that implement the IRWMP.	8.1, 8.2
Explanation of the certainty and longevity of known or potential funding for the IRWMP and projects that implement the Plan.	8.1, 8.2, 8.3
How operation and maintenance (O&M) costs for project that implement the IRWMP would be covered and certainty of operation and maintenance funding.	8.4

The Poso Creek IRWM Group, like other IRWM planning groups, requires funding mechanisms for operations, technical studies, annual reporting, IRWM Plan updates, grant applications, and project implementation. The funding sources, agreements, and mechanisms that are necessary to accomplish the Regional Goals and Measurable Objectives (see Sections 4.4 and 4.5) will vary depending on the project or program, and the funding opportunities available at the time of project/program implementation (which can include a combination of local, state, and/or federal monies). The RWMG tracks possible funding opportunities and seeks to maintain flexibility in the mechanisms within the Plan to “match” a given funding opportunity with the projects/programs. In this manner, it is the RWMG’s intent to optimize the funding mechanisms available for implementation of projects. At each public meeting, known funding opportunities are shared with all attendees and are circulated via the meeting agenda and minutes to the Interested Parties via an e-mail communication.

The role of the RWMG regarding funding mechanisms, financial administration, and funding opportunities is addressed in the governing MOU, which is included as Appendix C and further discussed in Section 2.1. Note that the RWMG has the authority to set an annual budget for general, core planning activity, but does not have the authority to fund or accept loans or grant contracts, therefore, one (or more) of the participating districts will assume the role of ‘primary applicant(s)’ based on benefits received and/or the location within a district’s service area of the particular project/program.



## 8.1 Funding Plan Activities

To date, the responsibility for funding the IRWM (Plan) activities has been assumed by the RWMG Participants. The RWMG has successfully supplemented local funding with state and federal grant funding for both planning activities and project/program implementation. At the time of RWMG formation, a DWR-provided Proposition 50 planning grant of almost \$500,000 helped to complete the Original 2007 Poso Creek IRWMP. Although the 2014 Plan update did not receive grant funding, the 2019 Plan update received \$250,000 from DWR's Proposition 1 planning grant. Since the original Plan, most of the cost of maintaining the planning activity has been borne by the RWMG Participants under a cost-sharing agreement contained in the MOU. To date, activities have taken place to maintain compliance with updated state planning requirements in 2012 and 2016, according to the DWR's IRWM Guideline Requirements, as well as the formulation of projects and programs that comply with the Regional Goals and Measurable Objectives of the IRWM Group. At the beginning of each year, an annual budget is developed and put to a vote by the RWMG that is based on the projected activities for the year. The annual budget includes funding for core planning and general coordination activities, plus focused planning and implementation efforts identified by the IRWM Group.

As previously stated in the discussion of Governance (reference Section 2.4), the RWMG prepares an Annual Report to document accomplishments and progress, data management, and note any changes to governance or policies. It is also intended that the report will contain a copy of the annual budget, which will serve to convey IRWM Group activities and identify the IRWM program costs to Stakeholders and Interested Parties. For example, Table 8.1 has been prepared to illustrate the type of project/program budgetary information that could be presented in the Annual report regarding planning and implementation financing. The RWMG intends to maintain the IRWM list of accomplishments and budgets as part of the annual reporting.

### *Updates to IRWM Planning*

Funding for the 2019 IRWM Plan update was made available by a Proposition 1, Round 1 Planning Grant signed into agreement by one of the participating districts of the Poso Creek IRWM Group. The Plan update will comply with DWR's 2016 IRWM Program Guidelines.

### *IRWM Plan Implementation*

The Poso Creek IRWM Plan has been (and is being) implemented utilizing multiple sources of funding to accomplish an impressive list of regional water and resource management measures, including the projects and programs listed in Appendix A2. The list includes structural projects and non-structural programs pursuant to the Plan's Regional Goals and Measurable Objectives. The proposed projects/programs were selected with the Primary Regional Goal in mind: to increase regional water supply reliability in response to a common concern faced by all water

users in the Region – the significant reduction of surface water supplies available to the Region. Through the actions of water districts and local agencies in the Region, various financial resources have supplemented local funding in order to implement projects and programs. Local funding has been contributed by the sponsoring agency(ies) through a combination of general fund and bond monies, both of which are ultimately funded by the landowners within the agency(ies). Local funding has also been supplemented by Federal and State grant funding sources.

The Poso Creek IRWM Group ‘Report Card’ (which has been included as Appendix A1) identifies approximately \$151 million of expenditures for projects and programs which have been implemented since adoption of the 2007 IRWMP. Of the total accomplishments identified and funded, approximately \$34 million was funded through various State-administered funding sources, accounting for about 23% of the total costs (principally from DWR), and \$30 million from various Federal sources, accounting for about 33% of the total costs (principally from USBR). Both sources supplement the nearly \$87 million in local (applicant) expenditures, which comprises over 57% of the total costs. Of this, nearly \$9 million has been used for DAC assistance. The identified funding summary does not include the many in-kind hours contributed by RWMG Participant (district) staff, as well as individual Stakeholders and Interested Parties. Most of the projects and programs that received Federal and State grant funding are either successfully completed or under construction (reference the Report Card in Appendix A1).

**Table 8.1** IRWM Group Planning and Implementation Financing Table Format

Year(s) <sup>1</sup>	Activity Title	Activity Type <sup>2</sup>	Category <sup>3</sup>	Purpose <sup>4</sup>	Support Agency <sup>5</sup>	Applicant <sup>6</sup>	<i>Continued (next)</i>
	<i>Example 1</i>	Program (Planning)	1		DWR	IRWM Group	
	<i>Example 2</i>	Program (Grant App)	2		USBR	RWMG	
	<i>Example 3</i>	Project	3			District	

<i>Continued (previous)</i>	Measurable Objectives <sup>7</sup>	Applicant(s) Share <sup>8</sup>	Applicant %	State Grant Share <sup>8</sup>	State Grant %	Federal Grant Share <sup>8</sup>	Federal %	Total Costs
		\$	%	\$	%	\$	%	\$
		\$	%	\$	%	\$	%	\$
		\$	%	\$	%	\$	%	\$

\* Note that ‘District’ would refer to a specific RWMG Participant(s) that applied for a grant that is related to the IRWMP.

<sup>1</sup> Year project or program was approved by the RWMG for inclusion in the IRWMP, following submission. May include ‘final year’ if project or program is completely implemented/constructed.

<sup>2</sup> Activity type in terms of project (structural enhancement) or program (non-structural). Programs are differentiated between ‘planning’ (e.g., IRWM Plans and other planning documents) or ‘grant apps’ (e.g., IRWM Program grant applications).

<sup>3</sup> “Category” number is used primarily for reference to categorize projects and programs implemented prior to this IRWMP Update and before the defined Goals and Objectives contained in the IRWMP Update. Sections include emphases on (1) Planning and IRWM Program Compliance Activities, (2) Community, Industrial, and Environmental - Specific Activities, and (3) Regional Infrastructure Enhancements and Program Activities.

<sup>4</sup> Generalized purpose for completing a project or program (e.g., Prop. 84 Planning, IRWM Guidelines, etc.)

<sup>5</sup> Agency(ies) that support or requires specific projects or programs that are required of the IRWM Group (e.g., DWR-required IRWM Plan Updates).

<sup>6</sup> Specific applicant(s) for grant-funding support for a specific project or program.

<sup>7</sup> Applicable Measurable Objectives met by a specific project or program, as defined in Section 4.5.

<sup>8</sup> Assuming grant-funding for project or program, the specific share of Total Costs awarded by State or Federal sources (primarily the Support Agency), and the total costs shared by the applicant (IRWM Group, District, etc.)

## 8.2 Federal, State, and Local Funding Sources

In general, funding sources to implement the IRWM Plan have come from local district or agency funds that have been supplemented by State and Federal grant funds. Prominent examples of state and federal funding opportunities have included the following:

- *USBR Mid-Pacific Region CALFED Water Use Efficiency Grant Program:* established to develop a long-term comprehensive plan that will restore ecological health and improve water management for beneficial uses of the Bay-Delta system.
- *USBR Mid-Pacific Region WaterSMART Grant Program:* part of the strategic plan for implementing the Secure Water Act that includes the facilitation of basin-wide water management improvements.
- *DWR Proposition 50 Agricultural Water Conservation Program*
- *DWR Proposition 84 Integrated Regional Water Management (IRWM) Grants Program*
- *DWR Proposition 1 Integrated Regional Water Management (IRWM) Grant Program*

The costs to prepare grant applications, project support documentation, project status reports, and grant completion reports have typically been funded by the RWMG Participants. In this regard, the RWMG has also worked with districts and communities in the Region that find it extremely difficult to fund the preparation of detailed and expensive applications.

## 8.3 Funding Certainty and Longevity

Individual districts and communities within the Region have, in general, been successful at funding and implementing projects and programs, which is documented in the IRWM Group ‘Report Card’ (reference Appendix A1). In this regard, the IRWM Group has effectively integrated local funding sources with federal sources (such as the USBR WaterSMART program) and state sources (such as the Water Use Efficiency programs). The IRWM Group seeks to maintain flexibility within the Plan to “match” a given funding opportunity with the projects/programs. In this manner, it is the RWMG’s intent to optimize the implementation of projects.

Although obtaining funding through grant applications is never certain, and is largely out of the IRWM Group’s control, the IRWM Group has practiced an approach whereby consideration is given to projects/programs that are best suited for a given funding opportunity. Notwithstanding this observation, funding opportunities are available to all participating entities. As the IRWM Group continues to implement projects and programs, it is presumed that any future grant applications will be strengthened as the already-implemented projects and programs realize regional benefits. Fundamentally, the RWMG does not rely on external (grant) funding to sustain the IRWM Group itself, thereby avoiding the uncertainty of securing funds to practice

regional planning. Several key projects are now constructed and operational, which provide purpose and momentum to the RWMG to continue to implement projects identified in the IRWM Plan. Due to the scale of some of the identified projects, they cannot be easily developed or implemented without external funding to supplement the local funding. Accordingly, it is reasonable to expect that the RWMG will continue its past practice of integrating state and federal funding opportunities with local funds.

As part of the annual budgeting process, the RWMG addresses the longevity of funding by consistently committing a minimum amount of \$30,000 per year (except for 2014, when the only funding used was for the Plan Update, which was completed with other funding) to fund the core activities which includes meeting four to six times per year for planning and implementation decisions. In addition, the RWMG assesses the longevity of funding by considering how to best supplement the core funding with additional amounts in place under existing contracts, funding agreements that may be pending, and any near-term funding opportunities that may ensure the implementation of the scheduled projects or programs. In general, funds which have been secured help to stabilize the activities through the contracted period, barring extreme circumstances, such as the DWR shut-down in 2010. However, in some cases, funding can even be accelerated under different circumstances, such as, the economic crisis that led to Federal Stimulus funding of projects within the Region and the acceleration of IRWM funds to help address the 2014 drought conditions in California. The longevity of the supplemental funding sources from USBR or DWR, to potentially provide new funds to the Region in the future, is also somewhat uncertain as State and Federal legislative and executive branches control budgets for these agencies and, in effect, the amount of funding available to grant programs. The IRWM Group, and the RWMG in particular, will remain vigilant regarding potential sources of grant funding from State and/or Federal agencies and continue to communicate the availability of grant funding opportunities with the Plan participants, Stakeholders, or Interested Parties.

It is reasonable to expect that the longevity of the IRWM Group will be driven by need and accomplishments, both of which have been significant. The need remains significant, and the IRWM Group's record of accomplishments provides considerable momentum to extend this record. Since the majority of the RWMG consists of district staff, they are available to meet on a regular basis. It has been more challenging to maintain functions outside of the agricultural water district charter, such as directly assisting communities within the Region, or directly assisting other functions, such as developing habitat suitable for wildlife. Some of the Region's challenges align with the emerging IRWM investment strategies identified by the DWR during recent strategic plan workshops. In particular, DWR states in the draft strategic plan: "Key considerations for these strategies are structuring financial assistance in a manner fostering collaboration and cooperation among regions, providing flexibility for local circumstances, and lowering barriers for participation in IRWM."

Emerging IRWM Investment Strategies derived from stakeholder input at the strategic plan workshops are listed below:

- Provide base-level funding to all active regional water management groups in the state to help support key operations, including stakeholder engagement and regional planning.
- Allocate funds to substantially increase the state's level of service to regional water management groups, including technical support, data management systems, water management analysis tools, and public outreach.
- Provide non-competitive funding to regional water management groups to address statewide priorities, such as disadvantaged community critical water supply needs, inter-regional groundwater overdraft conditions, reduced dependence on the Sacramento-San Joaquin River Delta, and source area protection.
- Continue competitive grants to assist regional water management groups in meeting water management needs of their regions, while promoting local project selection and prioritization processes.
- Invest in state leadership and innovation to better support IRWM through the alignment of state and federal policies, programs, and regulations.

#### **8.4 Funding Project and Program Operation and Maintenance**

Operation and Maintenance (O&M) costs are included in the evaluation of both economic and financial feasibility for a given project/program. Any given agency has certain statutory authorities regarding how it collects monies to fund its operations. Each of the water management agencies/districts within the Region typically collects its monies through a combination of acreage assessments and water-use assessments to balance the agency's/district's budget. Accordingly, the landowners within the district(s) which is(are) responsible for constructing and operating a project are also responsible for the O&M costs. The certainty of this funding is as certain as the future viability of the given district(s), most of which have been operating for several decades. In summary, the RWMG is not responsible for covering the costs of O&M expenses; rather, individual project/program sponsors or beneficiaries are responsible for these ongoing costs and monitoring metrics (see Section 7.3).

## 9.0 Technical Analysis

In accordance with the IRWMP Proposition 1 Program Guidelines, this section addresses the ‘Technical Analysis’ Plan Standard, which includes the requirements shown in the following table (along with identification of the specific subsection(s) where each requirement is addressed).

Requirement	Plan Section(s)
Data and technical analysis used in development of the plan.	9.1, 9.2, 9.3, 9.4, 9.5, 9.6, 9.7

This section describes the technical information which was relied upon, as well as the analyses and methods which were employed, in the preparation of this Plan. To a large extent, the data and analyses which provided the basis for both the 2007 IRWMP and 2014 Update remain valid, particularly as related to the development of the historical baseline (1981-2005) of water supplies and demands in the Region. For ease of reference, the relevant chapters from the 2007 IRWMP are included herein as Appendices F1 through F3.

Three primary sources of surface water supplies are imported to the Region (a fact which is still true even with the addition of SSJMUD to the IRWM Group) which supplement groundwater pumping (reference Section 3.3 for more regional details). Given the changing and declining reliability of these supplies; the expiration of the SWP contracts in 2035, as well as the time that it will take to implement a Delta “fix” (i.e. state-wide efforts to improve reliability of Delta exported-supplies while adhering to environmental concerns); a 20-year planning horizon is considered reasonable for the purpose of projecting water supplies and demands in the Region. The scope of this 20-year planning horizon is limited by the availability of annual data, and thus this planning period begins with the year of most recent available data, unless further projections are offered. For example, if the most recent data is from 2015, even though this Update is written in 2019, the 20-year planning horizon only extends to 2035, unless other data is available. The technical analyses related to the evaluation of regional water supplies and demands included the following elements, each of which is briefly described in the subsections which follow:

- Surface Water Use
- Land Use
- Groundwater Levels
- Absorptive Capability
- Projected Availability of Surface Water Supplies
- Projected Change in Water Demand
- Projected Change in Use of Surface Water Supplies

Regarding water supplies and demands, it is worth noting that this Update is being written concurrently with Groundwater Sustainability Plans (GSPs) for the Region (in accordance with SGMA). Thus, to ensure that all water supply and demand projections (and the

specific methodologies going into their analysis) are consistent with those to be provided to the State in these GSPs, some of the discussion of this data in this Update is of a more qualitative than quantitative nature. This is done with the understanding that certain trends (when mentioned specifically) have remained largely in line with those provided in the 2014 Update. More recent data and projections can be found in future updates when these calculations for SGMA are complete for the Region, as well as within the GSPs themselves when they are complete.

## 9.1 Surface Water Use

Each of the water agencies within the Region maintains records of surface water diversions. Monthly data were collected from each agency for the 25-year period extending from 1981 through 2005; which provided the historical baseline that was evaluated in the 2007 IRWMP, 2014 IRWMP Update, and this 2019 IRWMP Update. The sources of water supply included Kern River, Poso Creek, State Water Project, and the Central Valley Project. The annual fluctuation in the amount of water delivered into the Region from each of these sources of supply is illustrated in Figure 9.1 for the historical baseline.

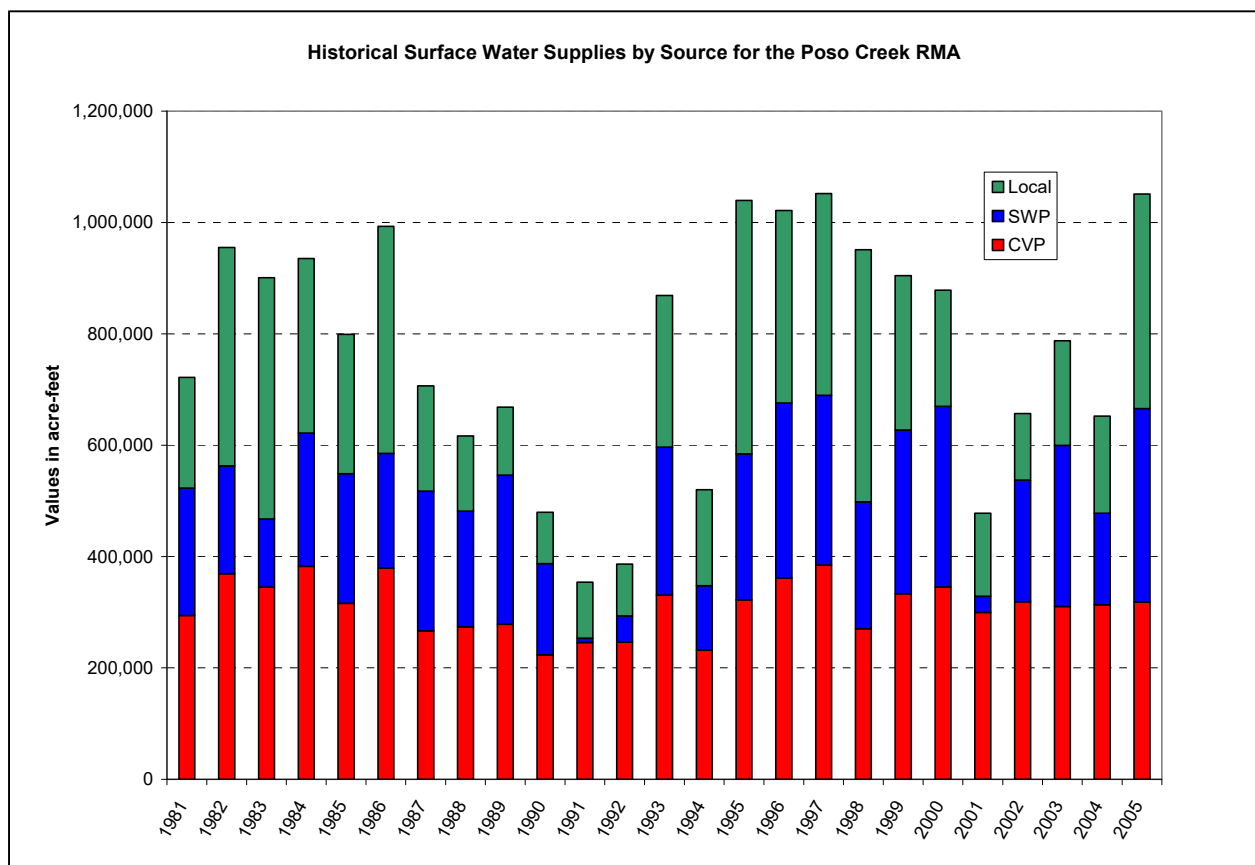

**Figure 9.1** Annual Fluctuations in Surface Water Supplies Delivered to the Region.

These data provided the historical baseline against which to measure projected changes in the availability and use of surface water going forward (reference Section 3.5 and Appendix F2).



Changes in the availability of surface water can be the result of regulatory changes, climate change (reference Sections 3 and 13.1), and water rights litigation.

## 9.2 Land Use

Each of the districts within the Region annually performs a land use survey within its boundaries and maintains records of the data. These data were collected annually for the historical baseline (1981 through 2005), and the total irrigated area was calculated for each year. In Figure 9.2, the annual irrigated acreage totals were charted over time to identify any apparent trends over this 25-year period for assessing future water demands for irrigated agriculture. The figure illustrates an increasing trend in the acreage of permanent crops, which is also confirmed in the 2014 land use data from Land IQ which is presented in Table 3.5 of this 2019 Plan Update (reference Section 3.4).

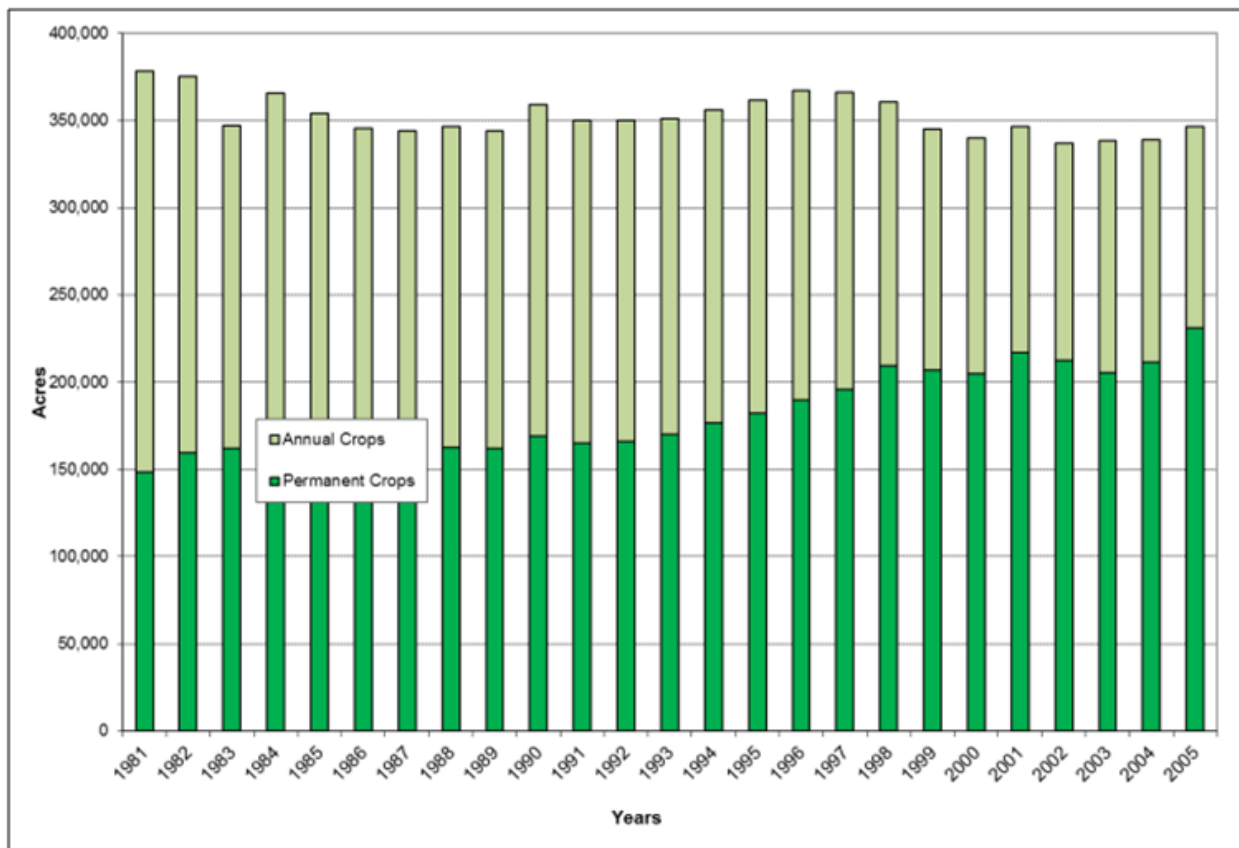
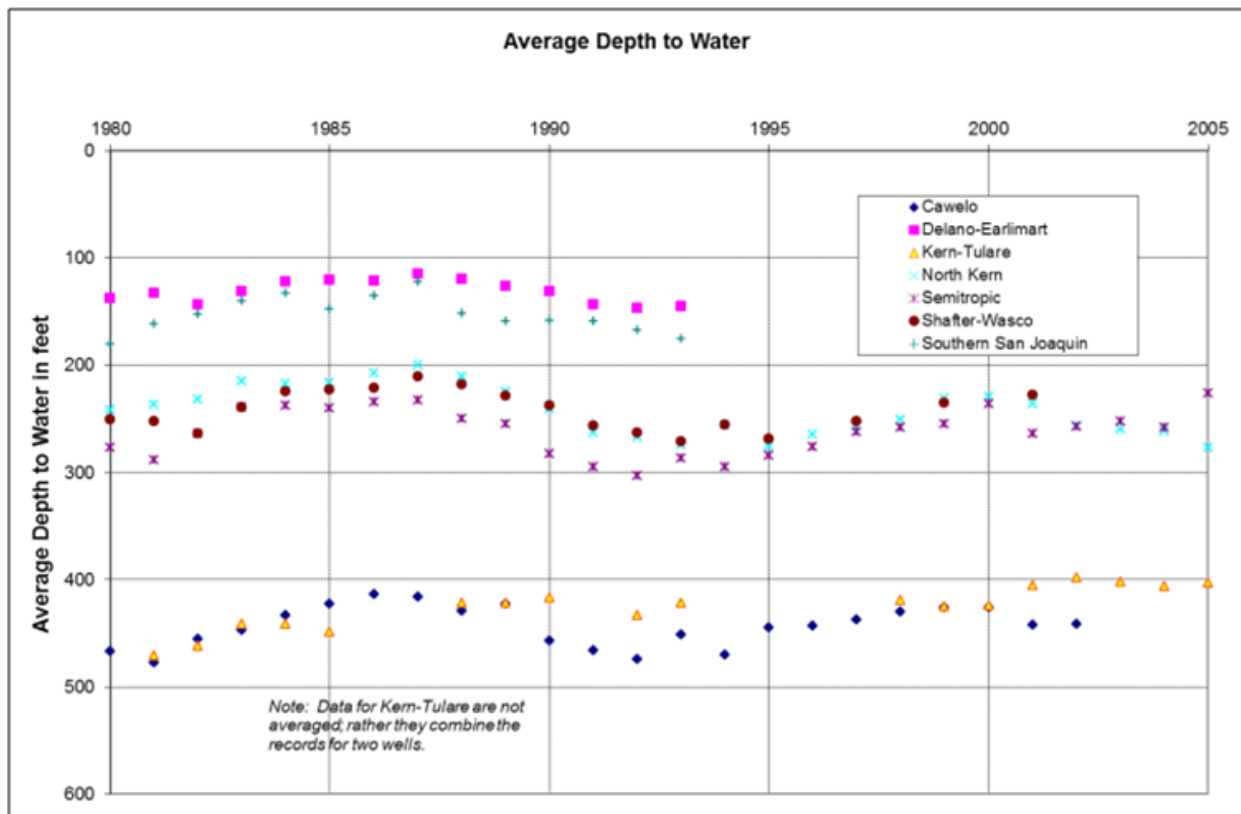

**Figure 9.2** Annual Fluctuations of Irrigated Acreage in the Region.

## 9.3 Groundwater Levels

Typically, on a semiannual basis (spring and fall), each of the districts within the Region measures the static depth to groundwater in several deep wells within its boundaries. The wells are spatially distributed throughout each district’s service area. Data was collected and compiled

for the average of the spring water-level measurements for each district. While each district was the primary source of the necessary data, other sources included DWR and USBR. For each agency, the average (static) depth to groundwater was charted over time (1981-2005) and compared one to the other, as well as to the corresponding diversion of surface water to the Region. This largely graphical analysis was conducted for evaluating the relationship between surface water diversions and groundwater levels, as well as the similarities in the groundwater level response between the areas represented by each agency. Figure 9.3 presents these average water level data for each of the agencies within the Region. Groundwater use in the Region was further discussed in Section 3.4.

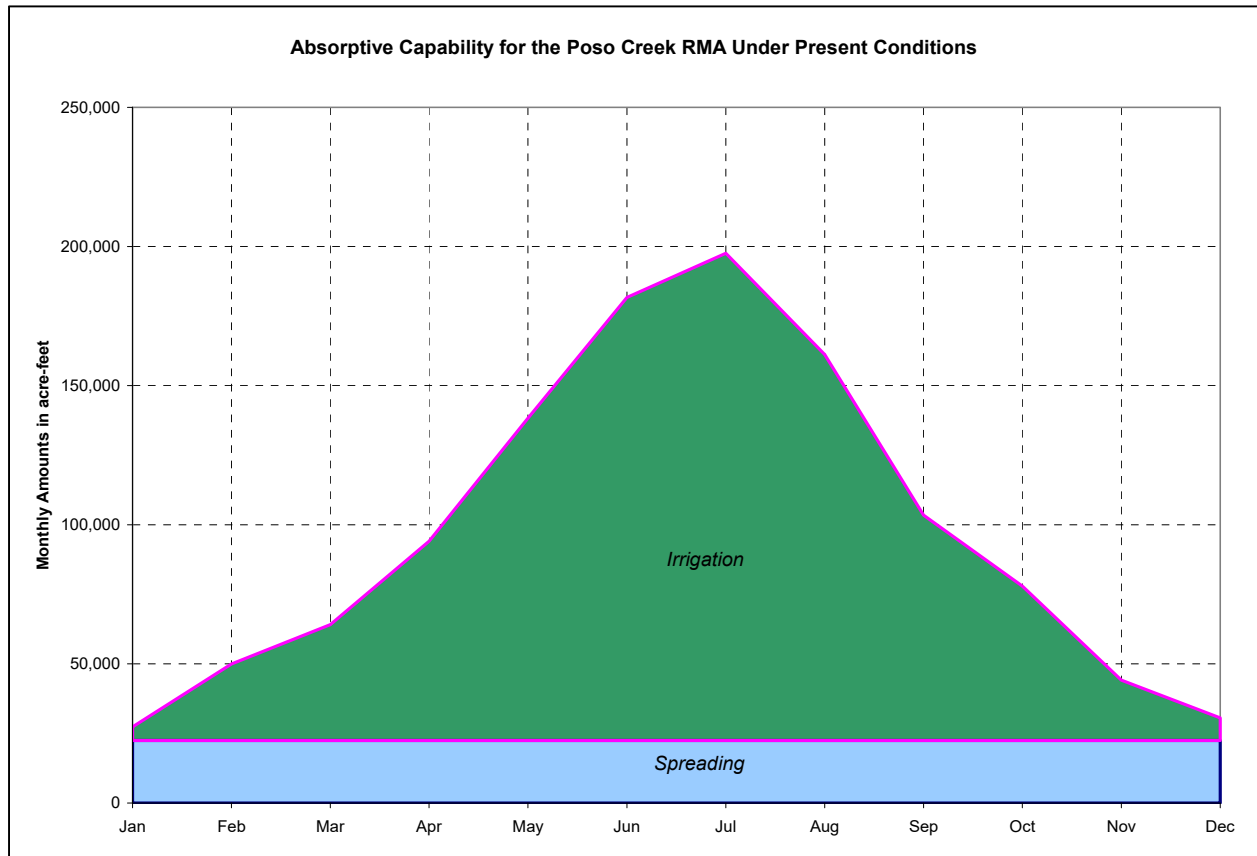

**Figure 9.3** Annual Fluctuations of Average Depths to Groundwater in the Region.

## 9.4 Absorptive Capacity

Absorptive capacity refers to the ability to divert and beneficially use available surface water supplies within the Region. There are two components to absorptive capacity; an irrigation component, where surface water supplies are used to meet irrigation demands; and a spreading component, where surface water supplies are delivered to spreading basins to recharge underlying groundwater. As part of the 2007 IRWMP baseline analysis, each component was determined on a district-by-district basis by inspection of records of historical monthly deliveries to irrigation and spreading which were provided by each district. In other words, actual operational experience was the basis for assessment of the reasonable maximum irrigation deliveries and spreading deliveries

under present conditions (all on a monthly basis). Figure 9.4 was prepared to illustrate the Region’s average monthly absorptive capacity under the level of development which corresponded to the end of the historical baseline.



**Figure 9.4** Average Monthly Absorptive Capacity in the Region.

## 9.5 Projected Availability of Surface Water Supplies

Surface water sources are subject to natural variations in hydrology. However, the three principal sources are subject to reductions in the available supply as compared to the historical baseline for reasons not related to hydrology (reference Section 9.1). These sources primarily include the Kern River and the two sources of imported supplies: the SWP and the CVP. The following subsections address the availability and reliability concerns regarding these sources of supply (reference Sections 3.1, 3.5 and Appendix F1).

### *State Water Project (SWP)*

Monthly data were obtained from DWR in support of the projected annual availability of “Table A” and “Article 21” water found in the 2017 SWP Delivery Reliability Report. These data reflect 2017 (existing) and 2037 (future) conditions of development. Within the Poso Creek Region, Semitropic WSD and Cawelo WD are “member units” of the Kern County Water Agency

and contract for the delivery of SWP water. Each district's pro rata share of "Table A" and "Article 21" water was determined on the basis of contractual allocation. Details of this can be found in Chapter 3 of this plan, as well as the 2017 Capability Report itself.

### *Central Valley Project (CVP)*

Projections of the availability of contract water supplies to each of the three CVP-Friant contractors in the Region were obtained from Mr. Dan Steiner for the period extending from 1922 through 2004. Mr. Steiner is a consulting engineer who has been involved for many years with the San Joaquin River Settlement and has modeled the availability of water under the terms of the Settlement using a computerized operations simulation model which was developed for that purpose. Mr. Steiner provided data for three types of water: "Class 1", "Class 2", and "Other". It is noteworthy that this model has also been used as the development tool for the simulation of Friant Division operations within CALSIM II<sup>1</sup>.

### *Kern River*

In the mid-1970s, the City of Bakersfield entered into long-term water supply contracts which provided for the delivery of 70,000 acre-feet per year (average over the 35-year life of the contracts) of the City's Kern River supplies into the Poso Creek Region. The basic term of these contracts expired at the end of 2011 and, while the contracts provide for an extension term, the City of Bakersfield has advised that this supply will no longer be available to the Poso Creek Region. In addition, the City of Bakersfield has filed to appropriate other Kern River supplies which have historically been diverted and used in the Poso Creek Region. Accordingly, solely for this Plan, it has been assumed that the above-referenced 70,000 acre-feet will no longer be available and that all other Kern River supplies historically used within the Region will be unaffected.

## **9.6 Projected Change in Water Demand**

Irrigated agriculture is the predominant water use in the Region. Irrigation water requirements could change because of a change in total irrigated acreage, a change in crop types, and/or a change in crop evapotranspiration owing to climate change. Either an increasing or decreasing trend in total irrigated acreage would likely have the most significant potential to change the demand for water compared to fluctuations in other types of water uses, particularly over a 20-year planning horizon. Accordingly, the total irrigated acreage within the Region was

---

<sup>1</sup> Water resources planning software regarding CVP delivery and reliability in the Central Valley developed and maintained by the DWR.

tabulated and charted over time to evaluate the year-to-year fluctuations and to identify any apparent trends (reference Figure 9.2). Regarding changes in crop types, the increasing trend in permanent plantings is having the effect of increasing demand to the extent that the annual crops which are being replaced have a lower irrigation water requirement. For instance, there has been a sizable increase in permanent almond crops in the Region. Finally, it is noteworthy that any additional urban development would remove a like amount of irrigated agriculture, which would simply trade one demand for another, with little measurable change in total demand over the 20-year planning horizon (reference Section 3.2 and Appendix F2).

Land that is used for annual crops can be fallowed when water supply is limited, but permanent crops must be watered every year. Thus, as stated by the Poso Creek IRWM Group in a previous Environmental Assessment for their 25-Year Groundwater Banking, Transfer, and Exchange Program, as surface water supplies reduce and pressure on groundwater resources increases, fallowing certain agricultural lands is an option available to the Region.

Regulatory restrictions on pumping from the Delta, especially since 1991, has severely impacted the reliability of CVP-Delta supplies to the Region, as previously discussed in Chapter 4 of the 2007 IRWMP.

## **9.7 Projected Change in Use of Surface Water Supplies**

A spreadsheet model was developed by GEI Consultants to perform operations studies on a monthly basis (reference Appendix F2) for the 2014 Update, which has been included in this Update to ensure the projections given are not inconsistent with the ones to be shortly provided in the Region's GSPs (as explained earlier in this section). The hydrologic period extending from 1922 through 1994 was used as the period over which projected surface water supplies were evaluated against the absorptive capacity. Ultimately, the amount of surface water that can be absorbed (i.e. diverted and used) within a given district is a function of the available supply, conveyance capacity from the source of supply to the district, and internal absorptive capacity. The evaluation was conducted on a district-by-district basis, considered only the contract supplies available to that district, and followed these generalized steps:

- (1) Consider the extent to which unregulated supplies available to a given district satisfy the irrigation absorptive capability of that district (on a monthly basis).
- (2) Consider the extent to which any remaining unregulated supplies can satisfy spreading absorptive capacity, if any (on a monthly basis).
- (3) Consider the extent to which regulated supplies available to a given district satisfy the remaining irrigation absorptive capability (on an annual basis).

As a result of applying these tests, any remaining irrigation absorptive capacity, spreading absorptive capacity, regulated supplies, and unregulated supplies were quantified for

each district. In other words, absent other arrangements, these results reflect the best a given district could do with its own supplies and absorptive capacity. The projected diversion and use of water under this scenario was then compared to the historical baseline to assess the impact of the projected changes in the availability of water supplies to the Region. Necessarily, the operations studies include many assumptions and criteria. The model was developed in a manner which facilitates sensitivity analyses regarding the assumptions and criteria which are expressed quantitatively. Finally, this same model was used to evaluate the water supply accomplishments attributable to improvements in absorptive capacity which would result from implementation of proposed projects.

## 10.0 Relation to Water Resources and Land-Use Planning

In accordance with the IRWMP Proposition 1 2016 Program Guidelines, this section addresses the ‘Relation to Local Water Planning’ and ‘Relation to Local Land Use Planning’ Plan Standards, which includes the requirements shown in the following table along with identification of the specific subsection(s) where each requirement is addressed.

<b>Requirement</b>	<b>Plan Section(s)</b>
List local water plans used in IRWM plan.	10.1
Plan relation to other planning documents and programs.	10.2
Dynamics between IRWM plan and other planning documents.	10.2
RWMG coordination to water management planning activities and programs, including Storm Water Resource Plans and Groundwater Sustainability Plans.	10.1, 10.2
Water management issues and climate change adaption and mitigation strategies from local plans.	10.3
Current relationship between local land use planning, regional water issues, and water management objectives.	10.3
Future plans to further a collaborative, proactive relationship between land use planners and water managers.	10.3
Sharing and collaboration with regional land use planning.	10.3

This section addresses the relation between the IRWM Group, specifically the RWMG Participants, and local water and land-use planning efforts. Local water plans are discussed in the context of planning which considers some portion of the Region. This generally includes the service areas of the water management districts, as well as other regional plans that affect the planning and management of the Region. As such, regional planning efforts are still local in nature; however, they encompass not only this Region, but neighboring areas as well. This distinction between local and regional planning efforts is made only for clarity in the Plan. As the following discussion illustrates, there are many water planning efforts which commenced, were completed, or were updated since adoption of the original IRWM Plan in 2007 and the 2014 Plan Update. The updated Plan addresses the water and land use planning efforts since the original IRWM Plan adoption.

### 10.1 Local Water Planning and Management

The Region is completely covered with the jurisdictions of water management districts, none of which overlap. All these districts are focused on water resource management, primarily for irrigated agriculture within their boundaries, and they include the following types of districts, as defined by the CWC: Water District, Irrigation District, Water Storage District, and Municipal Utility District. All the surface water brought into the Region is the result of water management actions and planning efforts by these districts (Section 3.5). These districts were formed for the purpose of securing and managing surface water supplies conjunctively with the underlying

groundwater within its jurisdiction. While the boundaries of these districts do not overlap, the underlying groundwater basin is common to all users since the underlying groundwater is hydrologically connected. Except for the cities within the Region, these districts have been responsible for preparing most of the local water management planning documents which are specific and unique to areas within the Region.

When formed, each of the districts prepared planning documents which evaluated available water supplies, projected water demands, static groundwater levels and quality conditions, all for the purpose of assessing the need for supplemental water supplies. These documents, which were prepared in the 1950s, 1960s, and 1970s, provided a proverbial ‘road map’ for each district’s operations for many years. Over time, with increasing costs and an increased emphasis on irrigation efficiency, combined with increasing uncertainty in supplemental water supplies, a new emphasis was placed on planning efforts leading to the preparation of Groundwater Management Plans (GWMPs), Agricultural Water Management Plans (AWMPs), and Water Conservation Plans (WCPs) managed and reviewed by DWR and/or USBR. In lieu of GWMPs, Groundwater Sustainability Plans (GSPs) are due in 2020 for each Groundwater Sustainability Agency (GSA) in the Region, as each member of the Poso Creek Group is part of a critically overdrafted groundwater basin. GSPs will require five-year updates through the year 2040, and future IRWM Updates will include any new information regarding projects, land use, groundwater levels, and all other parameters relevant to this IRWM discussed within the GSP. On the municipal side, cities have traditionally prepared General Plans providing a detailed documentation of the physical, social, and economic needs of a municipality and its people. Three of the cities in the Region are required to prepare Urban Water Management Plans (UWMPs), which provide considerably more detail regarding municipal water supplies and demands. Table 10.1 provides a summary of the agricultural and municipal agencies which have completed the planning documents mentioned above.

**Table 10.1** Status Summary of Local Water Planning Efforts (Year Adopted)

<b>Entity</b>	<b>Groundwater Mgmt. Plan</b>	<b>Agricultural Water Mgmt. Plan</b>	<b>Water Conservation Plan</b>	<b>Urban Water Mgmt. Plan</b>	<b>General Plan</b>
<i>Regional Districts</i>					
Semitropic	2012	2015	--	--	--
North Kern	2012	2015	--	--	--
Cawelo	2007	2015	2010	--	--
Shafter-Wasco	2007	2016	2013	--	--
Kern-Tulare	2012	2016	2013	--	--
Delano-Earlimart	2007	2016	2013	--	--
Southern San Joaquin MUD	--	2012	2013	--	--



<i>Regional Cities</i>					
City of Delano	--	--	--	2017	2005
City of McFarland	--	--	--	--	2011 <sup>1</sup>
City of Shafter	--	--	--	2016	2016
City of Wasco	--	--	--	2013	2016

<sup>1</sup>City of McFarland Land Use Element Update

As noted in Table 10.1, several plans have been prepared or updated since adoption of the Poso Creek IRWMP in 2007 and the Update in 2014 and have been considered in the preparation of this Plan Update. Each of the above-listed local plans is applicable to the jurisdiction of the preparing entity, the city limits or sphere of influence for the cities, and the official boundaries for each of the districts reflecting the reach of their statutory authority. The boundaries of the districts were set at the time of formation and have only changed with relatively infrequent annexations or de-annexations, all of which must be processed through the Kern County Local Agency Formation Commission (LAFCO) or county-applicable LAFCOs. The Poso Creek IRWM Plan is a direct reflection of the above-listed local planning efforts inasmuch as all but one of the districts located in the Region are active members of the RWMG, either as a direct RWMG Participant or Stakeholder. The principal local planning efforts which were considered and reflected in the preparation of this Plan Update are described in the subsections which follow.

### *Groundwater Management Plans*

All six of the local GWMPs in the Region have been prepared by members of the RWMG, and each plan is applicable to each member’s jurisdiction (reference Table 10.1). However, the common groundwater basin provides a common denominator, which tends to unify the Region with regard to water management objectives and strategies especially regarding groundwater use. Note that GWMPs are being replaced by Groundwater Sustainability Plans (GSPs), currently being written and due in 2020 for this Region. These plans will require updates every five years, and describe sustainability goals with explanations on how to achieve them in 20 years, with a 50-years planning and implementation horizon. The Basin Management Objectives (BMOs) for the formerly-used GWMPs articulated in each of these plans, representing the basis for water management, are summarized below:

- Semitropic Water Storage District, Latest Plan: 2012
  1. Maintain groundwater levels at economically viable pumping lifts for the overlying agricultural uses.
  2. Protect groundwater quality in general and minimize increases in salinity.
  3. Avoid conditions conducive to inelastic land surface subsidence.
  4. Protect and preserve surface water rights and contracts.
  5. Protect and preserve surface water quality.
- North Kern Water Storage District, Latest Plan: 2012

1. Maintain groundwater levels at economically viable pumping lifts for the overlying agricultural uses.
  2. Protect groundwater quality in general and minimize increases in salinity.
  3. Avoid conditions conducive to inelastic land surface subsidence.
  4. Protect and preserve surface water rights and contracts.
  5. Protect and preserve surface water quality.
- Southern San Joaquin Municipal Utility District, Latest Plan: 2012
    1. Maintain groundwater levels at economically viable pumping lifts for the overlying agricultural uses.
    2. Protect groundwater quality in general and minimize increases in salinity.
    3. Avoid conditions conducive to inelastic land surface subsidence.
    4. Protect and preserve surface water rights and contracts.
    5. Protect and preserve surface water quality.
  - Cawelo Water District, Latest Plan: 2007
    1. Provide basin users with a long-term, reliable and affordable high-quality groundwater supply.
    2. Maintain the rights and beneficial uses of groundwater users within the basin.
    3. Maintain local control over groundwater to the fullest extent possible.
    4. Promote public participation and involvement in local groundwater management efforts.
    5. Develop an effective dispute-resolution mechanism.
    6. Develop funding mechanisms for the groundwater management plan.
  - Shafter-Wasco Irrigation District, Latest Plan: 2007
    1. To promote and realize groundwater resource protection.
    2. To facilitate groundwater resource sustainability.
    3. To develop groundwater resource understanding.
    4. To develop groundwater basin understanding.
    5. To promote and facilitate information dissemination regarding the groundwater resource.
  - Kern-Tulare Water District, Latest Plan: 2012
    1. Maintain or improve groundwater levels within the District.
    2. Control degradation of groundwater quality.
    3. Limit land subsidence.
  - Delano-Earlimart Irrigation District, Latest Plan: 2007
    1. Stakeholder Involvement.
    2. Monitoring Program.
    3. Groundwater Resources Protection.
    4. Groundwater Sustainability.

5. Groundwater Operations.
6. Groundwater Planning and Management.

The common theme among these BMOs is groundwater quality and quantity protection and sustainability, which is carried into the IRWM Plan and represents several of the IRWM Group's Measurable Objectives (Section 4.5). At the present time, the BMOs do not include specific triggers, limits, or other criteria with regard to water levels or water quality and the use of groundwater to meet demands in each of the districts. If specific triggers, limits, or other criteria are adopted in the future, then these would have to be reconciled and reflected in a future update of the IRWM Plan.

The GWMPs are not required to be updated on a regular schedule; rather, they have been updated or amended in response to changed conditions, adoption of new management strategies, and/or changes in statutory requirements related to the content or preparation of a plan. In this regard, three of the six plans have been updated since adoption of the original IRWM Plan in 2007, and SSJMUD also produced an update in 2012. Moreover, with updates to the IRWM Plan the most recent local plans will be considered.

Multiple districts, primarily the State (SWP) and Kern River water supply contractors, have prepared or are in the process of preparing and adopting AWMPs in compliance with the requirements of the Water Conservation Act of 2009 (SBx7-7); the Agricultural Water Management Planning Act, and the Agricultural Water Measurement Regulation requirements (reference Table 10.1) Other districts, primarily Federal (CVP) water supply contractors, prepare a plan with similar content as a requirement of their water supply contracts with the federal government. These latter plans, formally referred to as WCPs, are now referred to as Water Management Plans (WMPs). Both AWMPs and WMPs are applicable to each district's jurisdiction. Unlike the GWMPs, which are linked by virtue of the common groundwater basin, the AWMPs amount to more of a 'report card' on the adoption and implementation of 'best management practices' within the jurisdiction of the agency preparing the plan, referred to as 'Efficient Water Management Practices'. In addition, the plans provide information respecting water supplies and water uses which is useful in the context of the IRWM Plan. Similar to UWMPs, SB7x7 stipulates that the AWMPs are to be updated every five years to reflect the changing climate and management conditions in a water management district. Note that whenever there is a need to update the IRWM Plan, the most recent AWMPs and WMPs for regional districts will be considered. It is beneficial to the IRWM planning process that the AGWMPs and UWMPs are on a coordinated update schedule.

### *Urban Water Management Plans*

Three cities within the Region are required to prepare an UWMP, and all three have met the requirements of the latest updates (reference Table 10.1). While each plan is applicable to the jurisdiction of the city which prepared it, all three cities rely solely on groundwater pumped from

the Region's common groundwater basin, which creates shared water management goals and strategies for all water users in the basin. These plans are especially useful in projecting growth in water use over time, with regards to increasing populations and municipal water use, and progress with regard to water recycling and treatment. These plans are updated every five years.

### *General Plans*

In compliance with state requirements, all cities within the Region prepare and periodically amend General Plans addressing the physical, social, and economic needs of the land within their present and presumed future boundaries (reference Table 10.1). With regard to content, the state requires that certain planning and management elements be addressed. With regards to regional water and resource planning, one of those elements is "Conservation" intended to address the conservation, development, and use of natural resources, including, but not limited to, water resources. For example, the conservation element within the General Plan for the City of Wasco contains objects to protect natural resources including groundwater to meet the needs of present and future generations. The General Plan contains policies and standards that recognize the importance to 1) protect areas of natural groundwater recharge, 2) expand programs to enhance groundwater recharge in order to maintain groundwater levels, 3) continue water conservations, and 4) protect human health by monitoring. To protect human health, the City groundwater resources will be monitored on a regular basis to test for bacteriological and toxic chemical components. Each city General Plan has similar objectives, policies, and standards within each planning element. By design, and the infrequent nature of updating these plans, they typically consider a 20- to 30-year planning horizon for resource and conservation management which is used to address municipal concerns in this Plan

Since the formation of the RWMG, draft plans, such as GWMPs or AWMPs, tend to be distributed among each the members of the RWMG as well as any Stakeholders or Interested Parties. These documents are included on the RWMG meeting agenda in order to monitor progress as well as to receive input, specifically regarding adoption or the intent to update/draft a planning document. These meetings are public meetings and are noticed to all who have requested to be on the distribution list (including Stakeholders and Interested Parties). This continued practice of transparency, specifically with the planning documents adopted by the districts, agencies, or cities in the Region, will help to facilitate the coordination of local and regional planning efforts going forward.

The regional collaboration involved in preparation of the Plan has and will continue to highlight the interests, strategies, and actions related to water resource management which are common throughout the Region. This has the effect of underscoring the similarities and thereby the benefits of working together to leverage the collective water management assets of the Region. In this manner, all regional planning efforts feed back to the local planning and decision-making efforts by each of the districts, agencies, or cities.

## 10.2 Regional Water Planning and Management

The planning efforts described in Section 10.1 are limited to those that are unique to some part of the Region; however, there are other regional planning efforts and entities with which to coordinate throughout the development of the Plan. Note that these planning efforts remain “local” in nature, inasmuch as they are all limited to Kern County and overlap the Poso Creek Region. Table 10.2 provides a list of these planning efforts and entities.

**Table 10.2** Summary of Regional Water Planning Efforts by Local Entities

Entity	Authority	Planning Efforts
County of Kern	County	General Plan (2009) <sup>4</sup>
County of Kern and City of Bakersfield	County	Storm Water Management Plan (2014)
Kern Council of Governments	JPA	Kern Regional Blueprint Program (2008)
Kern County Water Agency (KCWA)	Special Act	Kern IRWMP (2011)
Kern Groundwater Management Committee	JPA <sup>1</sup>	Regional Groundwater Management Plan (2015) <sup>1</sup>
Kern River Watershed Coalition Authority	JPA	Compliance with RWQCB’s General Order R5-2013-0120
North West Kern RCD	RCD <sup>3</sup>	Soil and water protection and conservation.
U.S. Army Corps of Engineers (USACE) <sup>2</sup>	Federal	Feasibility of a flood control dam on Poso Creek.
Poso Creek Regional Water Management Group (RWMG)	Regional	Drought Contingency Plan

<sup>1</sup> Formation of Joint Powers Authority (JPA) in progress. Completion of Regional GWMP anticipated by 2015.

<sup>2</sup> Investigation undertaken at request of, and with partial funding by, local agencies.

<sup>3</sup> Initially formed as a “Soil Conservation District”.

<sup>4</sup> Year reflects the last plan amendment.

It is noted that since the 2007 adoption of the original IRWM Plan and the 2014 Update, there are no additional regional water planning efforts, excepting the formation of GSPs. As described hereinafter, the entities listed in Table 10.2 have taken steps to become actively engaged in the water planning dialogue and members of the RWMG participate in several other water planning forums.

### *County of Kern*

#### I. General Plan

In broad terms, a General Plan is a long-term planning document which provides guidance to County officials who are charged with making decisions affecting the growth and resources within the unincorporated areas of the county. The County of Kern’s General Plan, last amended

in 2009, includes five objectives, two of which are pertinent to the management and planning efforts of the IRWM Group, as follows:

- Adopt policies and goals that reflect the County’s on-going commitment to consult and cooperate with Federal, State, regional, and local agencies to plan for the long-term future of Kern County.
- Ensure the protection of environmental resources and the development of adequate infrastructure with specific emphasis on conserving agricultural areas, discouraging unplanned urban growth, ensuring water supplies and acceptable quality for future growth, and addressing air quality issues.

These two objectives are noteworthy in the context of the Plan, inasmuch as they affirm the County’s commitment to consultation and cooperation with local planning efforts with regard to, among other matters, ensuring that water supplies are adequate in both quantity and quality. Specific policies regarding water resources are articulated in the ‘Land Use/Conservation/Open Space Element’ of the County’s General Plan. Following the policies are several implementation measures, the most pertinent (to the IRWM Group) of which is reproduced following.

- Encourage effective groundwater resource management for the long-term benefit of the County through the following:
- Promote groundwater recharge activities in various zone districts.
- Support for the development of UWMPs and promote Department of Water Resources grant funding for all water providers.
- Support the development of GWMPs.
- Support the development of future sources of additional surface water and groundwater, including conjunctive use, recycled water, conservation, additional storage of surface water, and groundwater and desalination.

These objectives and implementation measures clearly articulate the County’s support for local water planning, as well as specific water management practices which are captured in the Plan. The County even goes as far as reviewing certain water planning documents in the normal course of business, such as UWMPs, Water Supply Assessments, and environmental assessment (CEQA) documents. In 2011, the then current Director of the County’s Development Services Agency prepared correspondence to the Board of Supervisors which set forth an approach “... to proactively engage in water planning and groundwater management issues” by prioritizing the County’s participation in the various water planning forums within the County. Since that statement, the County has been hosting and participating in meetings of the KGMC. All RWMG Participant members have also participated in these meetings.

## II. Storm Water Management Plan

Together, the City of Bakersfield (City) and the County of Kern (County) submitted a 2014 update to the original 2006 Storm Water Management Plan (SWMP). The primary purpose of the SWMP is to describe the framework for management of storm water discharges, including program elements and control measures which both the City and County will implement to minimize the discharge of contaminants into storm water. Furthermore, the plan prohibits non-storm water discharges into MS4s and watercourses within the jurisdiction of both the City and County. Overall, implementation of the SWMP is anticipated to reduce pollutants in urban runoff and storm water to the maximum extent possible. This is expected to have many impacts to the Region, with the three most pertinent ones to the management and planning efforts of the IRWM Group being:

- Reduced flood damage by controlling storm water runoff by incorporating controls to address the diversion of runoff, insufficient storage capacity, and reduced channel capacity from sedimentation.
- Drinking water benefits by reducing pollutants from storm water runoff which require additional treatment costs or make the water undrinkable.
- Water storage benefits from reducing the heavy load of solids that can be deposited by storm water runoff, which lead to sedimentation of reservoirs and the loss of storage capacity.

The Storm Water Management outlines an approach to monitor the accomplishment of these objectives, which involves:

- Documenting activities to help evaluate whether program activities are meeting requirements of storm water permits.
- Observing increased awareness of storm water programs with residents, businesses, and municipal employees to change attitudes about pollution and control measures. Altering behavior may take the form of permanent post-construction structural Best Management Practices (BMPs), reducing pesticide use, and picking up after pets.
- Monitoring source load reductions and specific pollutants before and after a BMP or control measure is implemented.

Evaluations take the forms of Implementation Assessments, which analyze how well measures meet BMPs; Water Quality Assessments, which analyze environmental data to determine the quality of storm water discharge and the water bodies receiving the discharge; and Integrated Assessments, which evaluate relationships between program activities and water quality improvements. These goals and implementation measures clearly demonstrate the both the City and County's support for local water planning, as well as specific water management practices which are captured in the Storm Water Management Plan. These efforts require the active participation of all RWMG Participant members.

### *Kern Council of Governments*

The Kern Council of Governments (Kern COG) includes the County of Kern and the eleven incorporated cities within the County, four of which are located within the Poso Creek Region; namely, the cities of Delano, McFarland, Shafter, and Wasco. This association of city and county governments was formed to address transportation issues within Kern County. Several years ago, Kern COG commissioned a public outreach program with a broader scope, which is known as the Kern Regional Blueprint Program. This Program was designed to develop a preferred vision for transportation, land use, and the environment with the significant growth in population which is anticipated over the next 40 years. The following, taken from a Kern COG summary brochure, describes the intended effect of the program.

*The Kern Regional Blueprint is a new resource and communication tool for our region that will help our local communities accommodate future growth in new ways that preserve their community values and achieve their visions. We can achieve this through improved regional and local decision-making and increased involvement of all interests and segments of the population. The program strives to strengthen local decision-making through regional collaboration and integrated planning.*

Released in December of 2009, the final report for the Kern Regional Blueprint Program identified top issues for the future, which included the following discussion with regard to “water”.

*Many participants acknowledged the importance of maintaining an adequate water supply and noted that water quantity and quality are essential to supporting future growth. Participants recognized water as a limited resource and generally agreed that moderate to major change be initiated through proactive comprehensive planning of future development, and significant government regulation. Conservation will be necessary both at household and industrial levels. Many also noted the local impacts of exporting local water supplies. Some participants suggested considering new water quality standards, expanding use of gray water, developing mutual-cost programs, improving supply management, implementing price inflation adjustments for low-income community members, and promoting xeriscape landscaping. Additionally, some participants noted that flood protection should be a key element addressed in new developments.*

Kern COG has provided an important bridge between local and regional planning, specifically between the county and city governments in the Region, which is reflected in the Plan Update.

### *Kern County Water Agency (KCWA)*

The KCWA is a ‘Special Act District’ formed for the principal purpose of contracting with the State of California for the importation of SWP water to Kern County, and the administration of that contract among the many individual districts within the County which are contracted with



KCWA for the delivery and use of that water, as explained in Section 3.5. These districts are referred to as “Member Units” in the context of KCWA planning and management and they include two districts in the RWMG (Cawelo and Semitropic). Accordingly, the RWMG remains explicitly linked to the planning activities of KCWA and vice versa. Most recently, the KCWA has led the development of the Kern IRWM Plan update (2011), whose region encompasses the San Joaquin Valley portion of Kern County, including much of the Poso Creek Region. Considerable effort was expended in coordinating the development of the Kern IRWMP with the existing Poso Creek IRWMP, especially to resolve the boundary overlap issues. The KCWA continues to be notified of all meetings of the RWMG.

### *Kern Groundwater Management Committee*

In 2011, discussions among representatives of local public agencies (within the Kern County subbasin) commenced with regard to region-wide groundwater management. While most of the public agencies had prepared GMPs for their individual jurisdictions, regional groundwater management planning had not been completed to provide a link between the individual documents and the individual BMOs. This dialogue was initiated in early-2012 in the form of noticed public meetings (as the KGMC), being hosted by the County of Kern. Committee purposes include the following<sup>1</sup>:

- Coordinating groundwater management programs and activities.
- Identifying and addressing issues pertaining to sustainable groundwater management.
- Establishing a framework for local groundwater management.

Periodic meetings have continued and have resulted in the retention of a Consultant (GEI Consultants, Inc., Bakersfield, CA) to prepare a Regional Groundwater Management Plan pertaining to the entire Kern County Subbasin and applicable districts and entities. The Committee is also moving forward with organizing itself as a Joint Powers Authority (JPA). Most of the RWMG members participating in this Committee are expected to join the JPA in the near-future.

### *Kern River Watershed Coalition Authority*

In late-2011, several public agencies in Kern County executed a Joint Powers Agreement which formed the KRWCA for the primary purpose of interfacing with the Central Valley Regional Water Quality Control Board (CVRWQCB, Regional Board) on behalf of the landowners within their jurisdictions with regard to the drafting and implementation of a new long-term Irrigated Lands Regulatory Program (ILRP). These public agencies include four districts within the Poso Creek Region, all of which are also members of the RWMG. In late-2013, the Regional Board adopted a new program in the form of Tulare Lake Basin General Order No. 5-2013-0120, which requires compliance with its waste discharge requirements for any irrigated land with the

---

<sup>1</sup> Kern Groundwater Management Committee Request for Proposals for Consulting Services for Development of a Groundwater Management Plan.

potential to discharge to surface water or groundwater. The Authority's goals are listed following (KRWCA, 2013):

- Facilitate regulatory compliance for the General Order for Coalition Members.
- Continued advocacy for growers on water quality issues in various forums.
- Develop and implement economical and scientifically valid water quality monitoring programs for surface water and groundwater in the region.

With the Regional Board's adoption of the new General Order, the Authority is moving forward with the implementation and compliance phase. Future plan updates will benefit from the water quality monitoring programs developed by the Authority, and will include the planning and management enhancements proposed under this program.

#### *North West Kern Resource Conservation District (NWKRCDD)*

The NWKRCDD had its beginnings in the 1960s, with the formation of local Soil Conservation Districts. The RCD is organized for the protection and conservation of soil and water resources in an area of almost 600,000 acres, which includes the Poso Creek Region as mentioned in Section 3.7. Recall that the NWKRCDD has been an active member of the RWMG since its formation. The NWKRCDD's goals and objectives relate to the following: technical assistance, public awareness, conservation education, cooperation with other agencies (Federal, State, and local), and conservation district operations. Among its many activities, the RCD reviews and comments on land use boundary changes and on-farm conservation efforts, which were addressed in the formation of the Plan.

#### *U.S. Army Corps of Engineers (USACE)*

Though not a local agency, the USACE is included in this discussion inasmuch as they have undertaken investigation of the feasibility of constructing and operating a dam on Poso Creek, primarily for flood control purposes, at the suggestion of and partial funding by local agencies. In particular, these agencies include the County of Kern, the KCWA, and three districts within the RWMG (namely Cawelo, North Kern, and Semitropic). Aside from local rainfall and its attendant drainage, Poso Creek is the principal flood control concern in the Region as noted in Table 13.3. The NWKRCDD coordinates with these agencies with regard to the maintenance of the Poso Creek channel within the Region for flood control purposes.

#### *Poso Creek Regional Water Management Group (RWMG)*

At the time of this 2019 Plan Update, the RWMG is applying for funding to develop a comprehensive Drought Contingency Plan in accordance with the Bureau of Reclamation's (Reclamation) Drought Response Program. The Drought Contingency Plan developed would require the inclusion of drought monitoring processes, vulnerability assessments, mitigation

actions, response actions, an operational and administrative framework, and a plan update process. Furthermore, the Plan will require the input of a diverse range of stakeholders, many of whom are already involved in the IRWMP process. Another criterion for evaluation of the Plan by Reclamation is the extent to which the required elements of the Plan can be met by the RWMG within a two-year time frame, and thus decisions regarding formation of the Drought Contingency Plan would need to be made before the next IRWM Plan Update. Like the 2019 IRWM Plan Update, this Drought Contingency Plan will include consideration of climate change impacts to water supplies, in order to support long term resiliency to climate change. The formation and ultimate implementation of this Drought Contingency Plan would have further direct impacts to the RWMG, as it would also involve the input of all current stakeholders, allow for funding of drought mitigation projects which would address severe drought risks in the Region, and potentially impact water supplies or integrated water management otherwise.

### **10.3 Local Water and Land-Use Planning Efforts**

In essence, each land use has implications regarding water use; for example, golf course, residential development, irrigated agriculture, or undeveloped open space. In addition to the water “duty”, which represents the minimum water demand associated with each, land use can also impact water management particularly for the districts and agencies who share the common groundwater basin as a water resource. For example, recharge can and does occur through the deep percolation of applied irrigation water and through the purposeful use of spreading ponds. Accordingly, land-use decisions are also water-use and water-management decisions and must be addressed in a proper management and planning fashion that allows for the involvement of stakeholders or interested parties. The current relationship between land-use and water-management decision makers is described in this section, along with some thoughts regarding the potential to improve coordination going forward.

#### *Current Relationship*

In general, most land-use planning activities and actions rest with the county and the cities, with their visions and policies articulated in their respective General Plans. Collaboration between these agencies helps manage multiple water demands, adapt water management systems to climate change, and potentially offset climate change impacts. This is especially true in the age of SGMA, which requires careful and thoughtful collaboration to write and eventually implement the Region’s Groundwater Sustainability Plan, due next year in 2020.

The Kern Council of Governments is a forum which brings the County of Kern and the incorporated cities together. While their principal purpose has been to coordinate transportation planning, they have taken steps to broaden that mission as previously explained. In particular the Kern COG has recently commissioned a public outreach program which is known as the Kern

Regional Blueprint Program (2008). This Program was designed to develop a preferred vision for transportation, land use, and the environment with the significant growth in population which is anticipated over the next 40 years. Provision of an “adequate water supply” was identified as one of the top issues going forward and has gained traction as a common issue between the Kern COG and the IRWM Group.

The County of Kern has, for a long time, appointed water managers from throughout the County to the Kern County Water Resources Committee (KCWRC), which has the duty “*To advise and make recommendations to the Board of Supervisors with respect to the water resources and groundwater quality issues of Kern County*”. In addition to participation by two members of the Board of Supervisors and the County’s Director of the Development Services Agency, 20 members are appointed by the Board of Supervisors. This has become a beneficial forum for dialogue between those responsible for land-use decisions and those responsible for water resources planning and management. While regular meetings of this Committee have been suspended, meetings are called on an as-needed basis. For example, several years ago, meetings were relatively frequent as the County formulated a plan to address concerns regarding the land spreading of biosolids. With regard to participation in various water forums, it is understood that prioritization is necessary owing to the number of forums/meetings and staff limitations.

In addition to the long-standing KCWRC, the County has more recently formulated a plan for actively participating in the dialogue with those responsible for water resources planning and management within the County. The Director of the County’s Development Services Agency articulated his position in this regard in a letter report to the County Board of Supervisors (2011), which included the following:

*Since the County has legal authority over development and land use and is subject to State laws requiring a link between adequate water supplies and new development, it is of importance to the County to coordinate and actively participate in groundwater planning matters. The County’s broader interest of assuring that adequate water resources will be available to accommodate future growth for a variety of economic pursuits is also reason for the County’s engagement in water planning and management matters.*

This same letter report recommended the following actions in this regard:

- Schedule tri-annual meetings with the KCWA staff and prepare water issue and program status reports for the Board of Supervisors.
- Continue to implement water laws and programs and comment on water planning proposals.
- Prioritized participation in water program meetings.

As described hereinabove, in 2012, the County began hosting and participating in meetings of the newly formed Kern Groundwater Management Committee (KGWMC). Since that time, the

KGWMC has authorized the preparation of a Regional Groundwater Management Plan. This KGWMC has continued to meet and currently provides the largest forum for water and land-use planners to dialogue. In addition to County representatives, participation includes cities and districts. While these meetings are separate from the RWMG meetings, most of the RWMG members participate in this forum and are helping to fund the Regional Groundwater Management Plan.

Though attendance at Board of Supervisors' meetings, City Council meetings, or Planning Commission meetings is not regular, these meetings are attended by water managers in the Region from time to time when land use or project decisions are pending which have the potential to affect water supply or water quality. While the governance of the RWMG does not presently include a County representative, it does include a representative of the cities in the Region (see the list of IRWM Group participants at the front of the Plan) and there has been an open exchange of information.

### *Future Improvements*

A potential opportunity for improving the working relationship between water managers and land-use planners is the KCWRC. This committee should continue to meet on a more "regular" schedule, perhaps quarterly as opposed to an "as needed" basis, which would support an ongoing dialogue and set the stage for identifying and addressing potential water- and land-use issues before they become full-fledged issues. While these meetings will have a broader geographic scope, it is expected that it would serve the purposes of the Region with regard to this important dialogue. It is noteworthy that all three of the principal sources of surface water supplies within the County, SWP, CVP, and local watershed sources, as well as groundwater, are relevant to the Region. In addition to reports on the various sources of supplies, the agenda could include a status report from the RWMG. Other actions that could be considered to improve the working relationship between planning groups may include:

- Encourage the County of Kern in its plan to actively participate in water planning and management through prioritized participation in the various water forums.
- Provide an annual briefing to County planners on the RWMG's activities over the last year, as well as those activities which are anticipated for the year ahead.
- Review and comment on draft updates to the UWMPs in the Region.

## 11.0 Stakeholder and Public Involvement

In accordance with the IRWMP Proposition 1 Program Guidelines, this section addresses the ‘Stakeholder Involvement’ Plan Standard, which includes the requirements shown in the following table (along with identification of the specific subsection(s) where each requirement is addressed).

<b>Requirement</b>	<b>Plan Section(s)</b>
Involvement of DACs and tribal communities.	11.3
Decision-making process and roles that stakeholders can occupy.	11.1
Stakeholders necessity to address objectives and RMSs.	11.1
Collaborative process will engage a balance in interest groups.	11.1
Public process that provides outreach and opportunity to participate in IRWM plan.	11.4, 11.5
Process to involve and facilitate stakeholders during development and implementation of plan regardless of ability to pay; include barriers of involvement.	11.1

Recall that classifications of IRWM Group involvement include 1) Stakeholders, or members that are directly involved with or potentially affected by the planning and management efforts of the RWMG, and 2) Interested Parties, which are any private or public entities that have interest in the Poso Creek regional planning process but may or may not be directly involved (includes individual or general public interests within the IRWM Group). The RWMG makes a concerted effort to recruit and engage regional Stakeholders and Interested Parties that provide valued input on matters pertaining to their interests and the enhancement of water management in the entire Poso Creek Region. This section includes discussion regarding the involvement of Stakeholders and Interested Parties with planning and implementation activities in the Region, including State and Federal agencies, as well as the RWMG’s outreach strategy for maintaining and extending participation in the IRWM Group.

### 11.1 Regional Stakeholders & Interested Parties

Stakeholders (either as individual entities or organizations) and Interested Parties are critical to informing the IRWM process and supporting the RWMG in their development, update, and implementation of the IRWM Plan for regional planning and implementation efforts. These groups provide their input or contribute to discussions through participation in meetings and an open-discussion for communications platform, or through direct involvement in project or program work groups. For instance, the RWMG continues to rely on key Stakeholders who represent DAC interests and/or wildlife interests to provide information to address the objectives and RMS that are outside the responsibilities of an agricultural water district or the expertise of the district staff.

The RWMG maintains a transparent governance structure where all Stakeholders and Interested Parties are afforded the opportunity to contribute to the decisions made by the RWMG through participation in various Work Groups, as described in Section 2.3. Inasmuch as Stakeholders are directly involved with or potentially affected by RWMG decisions, they may hold more weight when working with the RWMG during the project or program review process. However, interest and participation in regional planning efforts by all of these groups is vital to the success of the IRWM Group and vital to the ability of the RWMG to accomplish their Regional Goals and Measurable Objectives.

CWC §10541(g) requires that the development of an IRWM Plan includes the opportunity for participation from appropriate local agencies (Interested Parties) and Stakeholders, as applicable to the Region. In this regard, the CWC identifies 13 different Stakeholder and local agency categories as listed below:

1. Wholesale and retail water purveyors, including a local agency, mutual water company, or a water corporation [WP].
2. Wastewater agencies [WW].
3. Flood control agencies [FA].
4. Municipal/county governments & special districts [GD].
5. Electrical corporations [EC].
6. Native American tribes that have lands within the Region [NA].
7. Self-supplied water users, including agricultural, industrial, residential, park districts, school districts, colleges and universities, and others [SS].
8. Environmental stewardship organizations, including watershed groups, fishing groups, land conservancies, and environmental groups [ES].
9. Community organizations, including landowner organizations, taxpayer groups, and recreational interests [CO].
10. Industry organizations representing agriculture, developers, and other industries appropriate to the Region [IO].
11. State, federal, and regional agencies or universities, with specific responsibilities or knowledge within the Region [SF].
12. Disadvantaged community members and representatives, including environmental justice organizations, neighborhood councils, and social justice organizations [DC].
13. Any other interested groups appropriate to the Region [OT].

The Stakeholders and Interested Parties involved in the IRWM Group are listed in the ‘IRWM Participating Districts & Agencies’ tables at the beginning of the Plan, and each have been identified with one of the above-described categories. The RWMG continues to make a concerted effort to encourage Stakeholder and local agency groups to participate in the regional planning and implementation processes, specifically those efforts during which decisions are made that may directly or indirectly affect these groups.

While significant outreach was performed during the development of the 2007 IRWM Plan, outreach efforts have continued through consistent periodic meetings of the IRWM Group, attendance of DWR IRWM planning workshops, and maintenance of e-mail communication list. These activities have consistently, over time, attracted more Stakeholders or Interested Parties to participate in the IRWM Group. An indication of the consistent involvement is evident by the Poso Creek IRWM Plan Implementation Meeting Attendance Log. Neighboring community water districts, such as the Angiola Water District and Allensworth Community Services District, have attended and regularly participated in RWMG meetings. Wildlife habitat interests associated with the Kern National Wildlife Refuge, the local duck clubs, the Tulare Basin Wildlife Partners, and the Semitropic Wildlife Improvement District receive the regular communication from the IRWM Group and work with the water districts to incorporate habitat components into water reliability projects that adhere to the Measurable Objectives stated in Section 4.5 (specifically Objectives “I”, “K”, and “L”). The Watershed Coordinators, the Federal Natural Resources Conservation Service (NRCS) and the USBR, and representatives for the incorporated and unincorporated DAC communities also interact regularly within the IRWM Group and with the RWMG. Several of the Stakeholders or Interested Parties, such as, the NRCS, the USBR, and DWR, are funding projects implemented by the RWMG.

The RWMG recognizes that some of these groups, such as, Native American tribes may not reside within the IRWMP boundary. The RWMG also recognizes that DAC communities may have limited financial resources and limited available time to participate directly in the IRWM Group meetings and implementation efforts, thus require additional communication and effort to effectively coordinate regional planning. There is also the risk that a time commitment or participation costs may deter other potentially willing individuals or organizations from participating in regional planning. The RWMG encourages individuals or organizations to participate under the classification of Interested Parties. To reduce any potential issues for an Interested Party to be involved due to cost, no fees are charged for direct involvement in the IRWM Group nor are they required to make a certain time commitment. These groups are free to attend the periodic monthly meetings and voice their concerns or input to the RWMG, and may participate in project or program Work Groups. The list of Interested Parties in the tables at the beginning of the Plan indicates those individuals or agencies which have been involved in the IRWM Group in the past to some extent serving on a work group for projects or programs that concern neighboring districts or agencies. The list is not exclusive, and may be altered over time as involvement in the IRWM Group changes, including changes between IRWM participant classifications, such as an Interested Party becoming a Stakeholder.



## 11.2 State, Federal, and Local Stakeholders

To this point, State and Federal Stakeholders have primarily referred to the DWR and USBR, respectively. Periodically, a representative from the DWR phones in or attends the RWMG meetings in person. Federal and state agency representatives also participate in field tours of projects when under construction. The Friant Water Users Authority interacts with the IRWM Group through several member water districts and is supportive of conveyance improvements (regional interties) that connect facilities in water districts with federal and non-federal water contracts.

The DWR has been largely responsible for providing the Proposition 1 Guidelines for regional planning and both the DWR and USBR have provided grant funding assistance to implement the projects and programs that accomplish the Regional Goals and Measurable Objectives of the IRWM Plan. The RWMG has worked directly with the agencies, specifically the DWR, through meetings and continuous communication to ensure that all regional efforts, such as the IRWM Plan itself, are compliant with all rules and regulations within the California Water Code governing regional water management. Since most of the water management districts in the Region are also State (SWP) and Federal (CVP) water supply contractors (as discussed in Section 3.3), these agencies also have a great deal of input on and stake in the planning and management decisions made by the RWMG. For the purposes of this IRWM Plan, these agencies are considered Stakeholders (as defined in Section 1.0), but are not ‘directly’ involved in the IRWM governance efforts nor do they pay fees to maintain the group since involvement is generally related to regulatory matters and planning review.

There are other State and Local agencies that are involved in the Poso Creek IRWM Group, such as, the Friant Water Users Authority that participate as Interested Party. The Interested Party groups have an interest in the planning and implementation efforts of the IRWM Group, but are not necessarily involved with project and program details or impacted by the planning efforts. The RWMG maintains contact with these agencies and encourages them to provide regulatory and planning review assistance based on project and program submissions on an as-needed basis.

The RWMG also maintains contact with the staff of several legislators within the State and Federal government for the purposes of maintaining awareness regarding State and Federal regulatory efforts and to expresses the interests of the IRWM Group to legislative representatives. Legislators whose jurisdictions include all or part of the Poso Creek Region include the following:

- Congressman Kevin McCarthy (23<sup>rd</sup> District of California, US Representative)
- Congressman Jim Costa (16<sup>th</sup> District of California, US Representative)
- Congressman Devin Nunes (22<sup>nd</sup> District of California, US Representative)
- Assembly Member Rob Bonta (State Assembly Member, 18<sup>th</sup> District)

- Assembly Member Rudy Salas (State Assembly Member, 32<sup>nd</sup> District)
- Assembly Member Vince Fong (State Assembly Member, 34<sup>th</sup> District)
- Senator Shannon Grove (State Senator, 16<sup>th</sup> District)
- Senator Robert Hertzberg (State Senator, 18<sup>th</sup> District)

Note that several of the State and Federal Stakeholders interact with the Poso Creek Group as part of their agency providing funding assistance to construct projects; however, they were not directly involved in developing the original IRWM Plan, 2014 Update, or this 2019 Update. The Plan has provided the basis for establishing the Regional Goals and Measurable Objectives (reference Sections 4.4 and 4.5) used for submitting projects and programs for State and Federal grant funding applications and maintaining contact with legislative and agency representation. As such, the involvement in the IRWM Group from these contacts has been somewhat indirect, but significant towards regional planning and implementation efforts.

### **11.3 Other Stakeholders and Disadvantaged Communities**

As mentioned in Section 6.5, several other Stakeholders have some connection to IRWMP development and implementation. These other stakeholders include local and state-wide organizations, agricultural water and environmental advocacy groups, and neighboring IRWM groups that are generally considered Interested Parties. DACs in the Region are directly represented through a DAC Work Group (reference Section 11.4) and participate directly in regional planning and management efforts. The RWMG has made a concerted effort to include some of these other Stakeholders and DACs in regional planning and management efforts, through involvement in RWMG meetings and formalized Work Groups (reference Section 2.3). The RWMG has tailored some of the planning and implementation efforts to provide direct benefits to these groups, such as applying for federal assistance through the Rural Water Supply Program.

All of the incorporated and unincorporated cities and communities in the Region qualify as “economically disadvantaged communities” based on the statewide median household income (as described in Section 3.9). DAC participation in the IRWM Group was formalized through the formation of a DAC Work Group, which also includes an elected DAC Representative who is a voting member of the RWMG. The voting DAC Representative reflects the substantial consideration given to the DAC communities’ needs during development and review of the Plan. Recall that one of the IRWM Group’s Measurable Objectives, was based on addressing the water-related needs of these DACs (see Objective “J” in Section 4.5).

Disadvantaged communities within the Central Valley, including those within this Region, are further represented by Self-Help Enterprises (SHE), a non-profit entity that provides technical services and support for families and communities to compete for resources in lower socioeconomic areas. The RWMG has worked closely with SHE for many years to identify DAC concerns and to promote potential solutions, either as standalone projects or programs or as

a component of an IRWM grant submission. In other words, proposed projects or programs that address DAC concerns are considered for IRWM funding opportunities, with specific benefits addressed in Project Descriptions. The RWMG recognizes that DACs have limited economic resources to utilize in addressing their concerns as an individual entity. Accordingly, the DAC Representative participates in the RWMG at no cost but, as a voting member, is in a position to influence in IRWM planning and implementation efforts. The RWMG makes a concerted effort, in coordination with SHE as appropriate, to assist these communities in qualifying for grant funding based on the goals and objectives of the IRWM Plan.

It is noted that there are no Native American tribal communities located in the Region (as mentioned in Section 3.9). Accordingly, there is no direct representation for Native American interests in Poso Creek IRWM planning and implementation efforts.

## **11.4 Public Involvement and Outreach**

The RWMG has developed and implemented a Public Involvement Process to ensure that the public is informed in the planning and implementation efforts undertaken by the IRWM Group, including the development and adoption of the IRWM Plan. This process is detailed in the Public Involvement Plan (PIP) drafted by the IRWM Group in September 2013 and updated in 2019 to supplement this Plan Update. It is included in Appendix H for reference. The PIP expresses the desire of the IRWM Group to ensure the public is aware of the existence of the Poso Creek IRWM Group for the Region, and their efforts towards addressing water management enhancements through planning and project/program implementation, and to promote public awareness regarding water resources issues in the Region. The PIP will continue to be updated as the need for greater or improved public involvement or outreach is identified. Development and adoption of the IRWM Plan update, and public involvement, follows the processes described in Sections 2.5 and 2.6, respectively.

As previously mentioned, the general public is encouraged to become involved in the IRWM Group as an Interested Party by attending the periodic monthly meetings or actively communicating with the RWMG through e-mail, letters, or other methods of communication. The lead agency, Semitropic WSD, maintains and archives information dedicated to the IRWM, including a schedule of meeting dates, agendas and minutes, list of RWMG Participants, Stakeholders, and Interested Parties, and documentation including the Plan. The RWMG makes available information and copies of the documentation to the public upon request. During development of the IRWM Plan, the RWMG also developed an easy-to-read brochure to communicate the background, vision, and mission of the IRWM Group to any interested parties or public.

## **11.5 Continuous Outreach and Involvement Strategies**

Most potential Stakeholders or Interested Parties in the Region are already aware of the efforts by the IRWM Group and have chosen to participate in the group to some extent through periodically participating in the RWMG meetings or receiving communication through the RWMG Chairman's e-mail list. The RWMG will continue to follow the PIP to expand involvement and outreach efforts. The PIP will be periodically assessed and updated if the need for improved outreach is identified. The RWMG will consider the effectiveness of the public outreach strategies as part of their annual reporting.

## 12.0 Coordination and Integration Standards

In accordance with the IRWMP Proposition 1 Program Guidelines, this section addresses the ‘Coordination’ Plan Standard, which includes the requirements shown in the following table (along with identification of the specific subsection(s) where each requirement is addressed).

Requirement	Plan Section(s)
Process to coordinate water management projects and activities of participating local agencies and stakeholders to avoid conflicts and take advantage of efficiencies.	12.1, 12.2
Neighboring IRWM efforts and ways to cooperate.	12.4
Areas where a state, federal, or local agency can assist in communication or cooperation.	12.3

The IRWM Group views ‘coordination efforts’ as the public outreach and organization of members, including RWMG Participants, Stakeholders, and Interested Parties, encouraging them to work together to accomplish the Regional Goals and Measurable Objectives stated in the IRWM Plan (reference Sections 4.4 and 4.5, respectively). These efforts can apply to specific tasks, and therefore may be facilitated via work group, or may be implemented by the group as on-going policies or procedures implied under the guise of day-to-day management of the IRWM Group. The goals of IRWM coordination include the following:

- Identification of opportunities to address project or program proposals that accomplish the goals and objectives of the IRWM Plan, while providing benefits to the IRWM members including RWMG Participants, Stakeholders, and Interested Parties, or inter-regional partners within neighboring IRWM groups;
- Awareness of inter-regional planning and implementation efforts, or individualized efforts within the Region, leading to a reduction in conflicts between these groups;
- Awareness of State and Federal agency resources, guidelines, and grant funding opportunities that align with local resources.

The IRWM Group has successfully planned and implemented various projects and programs in the Region that fit the goals and objectives of the IRWM Group. The implementation activity combines the viewpoints, participation, and diverse opinions of the participants and helps to focus them on unified efforts towards enhanced water management in the Region, thus, effectively accomplishing ‘integration’ of the group (reference Section 12.2). The following section describes the coordination efforts and processes for integrating water and resource management efforts by the IRWM Group.

## **12.1 Coordination and Integration in IRWM Group Activities**

The IRWM Group governance structure fosters and promotes both the integration and coordination of member districts, agencies, and interests (reference Section 2.2). Recall that the RWMG Participants entered a MOU that provides an organizational structure for the IRWM Group to be governed, with amendments to reflect changes to this structure, including (most recently) the addition of Southern San Joaquin Municipal Utility District. As stated previously, the effectiveness of the governance is dependent on the effectiveness of the individual leaders within each of the participating organizations, their roles and responsibilities, communication between these organizations, and contributions through established relationships which successfully binds the group together. In particular, the RWMG Participants came together with the idea that integrating their respective water resource and infrastructure assets would yield shared benefits in excess of what could be accomplished individually.

The RWMG Participants, and the DAC Work Group, are integrated into the planning and implementation efforts via their roles on the RWMG. Stakeholders and Interested Parties, including the general public or private/public organizations, may participate in the RWMG meetings and can serve on project or program work groups. The RWMG uses a variety of outreach methods to disseminate information regarding the IRWM Group's efforts, to foster interest in the group's planning processes, or to solicit comments on development of the Plan (reference Section 11.4).

Regarding project or program assessment and selection (for implementation), the RWMG uses an integrated process to solicit and review projects as described in Section 5.1. This process uses input from the RWMG, the Chairperson, and the assigned Work Groups which consist of IRWM members from the list of RWMG Participants, Stakeholders, and Interested Parties with a direct interest in a particular project or program. The process is meant to integrate and improve coordination between all IRWM Group participants and the RWMG Participants, who will eventually vote to determine the status for implementation per the IRWM Plan. The general benefits and impacts of implementing different types of projects, for entities within the Region and neighboring areas are discussed in Section 6.0. This information is intended to assist in the submission of new projects or programs for consideration by the RWMG, as well as to improve coordination during the review (and potential implementation) process. It is noted that the RWMG maintains a list of submitted projects and programs so that all parties are aware of the proposed efforts, to avoid complications or duplicated submissions. The projects and programs list is updated on an as-needed basis, and will be incorporated into the RWMG's Annual Report.

## **12.2 Resource Integration**

As previously mentioned, the Region includes important water resources and related infrastructure that facilitates local district and agency water management, and also facilitates regional water management between districts. Most of the entities within the Region either

pump from the underlying groundwater, a hydrologically-connected and shared groundwater subbasin (reference Section 3.4), or they conjunctively use surface water supplies from State, Federal, or Local sources, along with the underlying groundwater. Surface water use is governed by the water supply contracts under which those supplies are brought into the Region (reference Section 3.5). The integration and coordinated use of these resources involves data sharing, technical expertise, and management of the infrastructure operated by each district of the IRWM Group. The IRWMP enhances resource integration by focusing on improvements to regional planning and implementation or regional facilities ahead of individual district efforts.

### **12.3 State and Federal Agency Assistance**

Involvement of State and Federal agencies in the RWMG's planning and implementation efforts of the RWMG is covered in Section 11.2 of the Plan Update. These agencies can assist the IRWM Group by providing updated guidelines for regional planning, working with the IRWM Group to ensure all efforts meet those guidelines, and by making grant funding available to accomplish the Regional Goals and Measurable Objectives stated in the IRWM Plan. Recently, the DWR has completed updates to the IRWM program guidelines that provide improved procedures and thus improving the effectiveness of the IRWMP program.

### **12.4 Neighboring IRWM Regions**

The RWMG has committed considerable time and effort to support and strengthen working relationships with neighboring IRWM regions, specifically that immediately neighbor the Poso Creek Region and located within the DWR-specified Tulare Basin Funding Area (as shown in Figure 1.1). The Poso Creek IRWM Group has participated in a leadership role for this funding area in the past to help facilitate and to assist the DWR to coordinate interregional planning activities. Conflicts and issues with these other IRWM regions in recent-years have been minimal, as their boundaries are now well defined. Overlap issues have been resolved as noted in Section 3.11. Accordingly, the IRWM Group has remained actively involved with these neighboring regions through coordinated efforts which are described in Section 2.7. The IRWM Group maintains contact primarily with the Tule River, Kaweah, Westside, and Kings Basin IRWM groups to the north, the Kern IRWM group to the west, south, and east, and the Southern Sierra IRWM group to the northeast. Representatives of the RWMG have routinely met with surrounding IRWM groups at monthly Tulare Basin Funding Area coordination meetings and have worked cooperatively on matching neighboring boundaries in the past and focusing on projects or programs that impact areas adjacent to boundary lines. It was suggested that areas of "white space" (i.e., areas that are not governed by water management districts or agencies) that do not have an IRWM sponsor, including areas outside of Poso Creek Region or other IRWM regions, be provided a method for inclusion in an the IRWMP Program within the Tulare Basin Funding Area, as stated in the regular regional meetings.

Sections 6.2 and 6.3 describe how the Regional Goals and Measurable Objectives including the RMSs and project or program implementation may impact or provide benefits to the neighboring regions. As implied in that section, these regions face similar concerns regarding agricultural demand, reduced reliability of imported surface water supplies, and increased use of groundwater. Accordingly, the IRWM Group considers the greater impacts and benefits for planning and implementation efforts, and actively coordinates these efforts with the neighboring IRWM groups. It is noted that neighboring IRWM groups are encouraged to participate in Poso Creek IRWM Group efforts that may be of interest; either as Interested Parties or through participation in designated work groups (reference Section 2.3) that involve joint projects or programs or may involve resolving common issues.



## 13.0 Climate Change Assessment

In accordance with the IRWMP Proposition 1 Program Guidelines, this section addresses the ‘Climate Change’ Plan Standard, which includes the requirements shown in the following table (along with identification of the specific subsection(s) where each requirement is addressed).

<b>Requirement</b>	<b>Plan Section(s)</b>
Evaluate IRWM region’s vulnerabilities to climate change and potential adaptation responses based on vulnerabilities assessment in the DWR Climate Change Handbook for Regional Water Planning.	13.1, 13.2, 13.3
Process that considers GHG emissions when choosing between project alternatives.	13.4
List of prioritized vulnerabilities based on vulnerability assessment and IRWM’s decision making process.	13.3
Plan, program, or methodology for further data gathering and analysis of prioritized vulnerabilities.	13.3, 13.5
Climate change as part of project review process.	13.5
Address adapting to changes in the amount, intensity, timing, quality, and variability of runoff and recharge.	13.1
Consider the effects of sea level rise (SLR) on water supply conditions and identify suitable adaptation measures.	13.5

Climate change refers to the long-term change in the statistical distribution of weather patterns in precipitation, temperature, wind, and severe weather events over a time of decades, centuries, or millennia with respect to ‘historically-expected’ (average) weather conditions. Climate change can occur from both natural and anthropogenic causes; however according to the Intergovernmental Panel on Climate Change, most scientists agree that the high levels of anthropogenic greenhouse gas emissions have accelerated the rate of otherwise natural climate change. The potential impacts of climate change are far reaching, and the progression of these changes on environmental conditions has differed around the world. Climate models have become central to scientific understanding of how the Earth’s atmosphere and oceans are expected to change over time, but since they focus on a global scale, regional estimates of future climate require data of a finer spatial resolution.

Specific climate change impacts on the Region over time are difficult to predict. Rather, generalized effects on the regional and statewide climates can be predicted, such as changes in the volume, nature, and timing of precipitation in watersheds that provide water supplies for regional users. However, uncertainty is inherent to any climate change projections, especially associated with variability in worst- and best-case scenarios of GHG emissions, limitations in available historical datasets, and current scientific understanding of relationships between climate change and environmental effects. Uncertainties in these predictions means the IRWM

Group must adequately prepare for a large range of potential future conditions regarding water supplies and demand in the Region. The following section provides an assessment of the potential impacts of climate change on the Region, including an assessment of regional vulnerability, and the RWMG's response to these potential impacts. Climate change data will be provided in the Region's corresponding GSPs in 2020.

### **13.1 Effects of Climate Change on Regional Water Supplies**

As mentioned in Section 3.3, the surface water supplies for many of the districts in the Region are currently dictated by changes in the volume, nature, and timing of precipitation in the Sierra Nevada Mountains, which affects both local (Kern River and Poso Creek) and imported (SWP and CVP) water supplies. Accordingly, any adverse effects from climate change on the runoff from these watersheds would aggravate the ability of impacted districts to provide water supplies which are adequate to meet regional demands.

Regarding the State (SWP) and Federal (CVP) surface water supplies, the DWR examined 12 future climate scenarios in a report titled 'Using Future Climate Projections to Support Water Resources Decision Making in California' (Chung et al. 2009) to assess future reliability issues with these sources due to climate change. The 12 statewide scenarios represent projections from six Global Climate Models for higher and lower greenhouse gas emissions while taking into account potential Delta salinity intrusion due to sea level rise. For all climate projections studied, the reliability and overall volume of water delivered by the SWP and CVP water supply systems is expected to be reduced. For instance, by mid-century, median Delta exports through the SWP's Banks Pumping Plant are expected to be reduced by 7 percent for the lower greenhouse gas emissions scenario and by 10 percent for the higher emissions scenario. Mid-century changes in Delta exports for the 12 future climate scenarios range from an increase of 2 percent to a decrease of 19 percent. Current long-term reliability predictions of surface water deliveries via the California Aqueduct are expected to average 60 percent of contract amounts (DWR, 2011). Decreases in annual Delta exports due to climate change would reduce reliability even further, resulting in less water delivered south of the Delta, which directly affects the amount of water supplied to the Poso Creek Region.

#### **Address adapting to changes in the amount, intensity, timing, quality, and variability of runoff and recharge.**

Several investigations were conducted by the USGS California Water Science Center (CAWSC) regarding hydrological effects of climate scenarios in the Sierra Nevada Mountain Range (USGS 2009; Water Resources Research, 2012). As previously noted, the Region's surface water supplies are dependent on runoff from the Sierras. Each of these investigations predict that California's climate will become warmer (+2 to +4° C) and drier (10-15 percent) during the mid- to late-21st century, relative to historical conditions. These scenarios were based

on a commonly accepted projection of 21st century climate from the GFDL CM2.1 (Geophysical Fluid Dynamics Lab Climate Model 2.1) global climate model, responding to assumptions of rapidly increasing greenhouse-gas emissions. If these predictions materialize, runoff from the Sierra Nevada Mountains is expected to be much less reliable, with quantities presumably declining over time. Reduced surface water deliveries for agriculture in the Central Valley, combined with increased demands for irrigation water due to the increasingly warmer, drier climate, will result in increased use of groundwater, the impacts of which could include the following:

- Reduced base flow in streams;
- Reduced groundwater outflows;
- Increased depths to groundwater; and
- Increased land subsidence.

All other things being equal, increased depths to groundwater will result in increased power and energy requirements for groundwater pumping, which has its own greenhouse gas implications.

Local communities, rural residences, and businesses rely on groundwater from the Kern County Subbasin as their main supply (reference Section 3.4). Should climate change result in a reduction in water available from surface supplies, the increased frequency and quantity of groundwater pumping by agricultural water districts and other users will lead to a decrease of groundwater in storage without the necessary means of replenishing the depleted groundwater from storage. A greater examination of this will be present in the Region's respective Groundwater Sustainability Plans, due in 2020. According to another CAWSC study (Proceedings of the Eighth International Symposium on Land Subsidence, 2010); Kern County may expect land surface subsidence to increase in severity with the dewatering of aquifer materials beyond that which has been experienced historically.

## **13.2 Effects of Climate Change on Agricultural Water Demand**

The effects of climate change are expected to increase both daytime and nighttime temperatures in the Central Valley, resulting in lengthening of the growing season under much drier conditions. This general increase in temperatures, coupled with greater variability and unpredictability in precipitation, is expected to lead to increases in evapotranspiration resulting from warmer seasons; thereby creating an increase in agricultural water demand for irrigation, with potentially greater year-to-year variability.

As noted in Section 3.2, permanent crops, such as, grapes and fruit and nut trees, account for around 67 percent of the total irrigated area in the Region. These types of crops generally require adequate winter chill to produce economically viable yield. Increased temperatures in the Central Valley are expected to reduce winter chill hours, thus causing adverse effects on crop

yield. By the end of the century, the winter chill needed for these crops is predicted to disappear. Today, the number of hours of winter chill in the San Joaquin Valley has shrunk from about 1,500 a few decades ago, to approximately 1,000 to 1,200 hours (PLoS ONE, 2009). Some farmers are beginning to overcome this change by using new plant varieties.

Studies with neighboring IRWM Groups are now underway to prepare farmers for the likely impacts of climate change. Such efforts include breeding varieties of fruit trees which can withstand the decreased winter chill hours, developing tools to aid the crops in coping with reduced chill, and researching the temperature responses of orchard crops to better understand potential long-term effects. However, some solutions, such as replanting orchards with altered crop varieties or the installation of tools, may not be feasible for many growers.

### 13.3 Regional Vulnerability Assessment

Table 13.1 provides an assessment of the regional vulnerability to the potential climate change impacts using the ‘Vulnerability Assessment Checklist’, found in the ‘Climate Change Handbook for Regional Water Planning’ (DWR, 2011). This checklist provides a further evaluation of the effects on regional water demands and supplies, as well as water quality, flooding events, environmental and ecosystems, and hydropower systems.

Vulnerability ratings, identified in Table 13.1, are based on presumed level of impact to Regional conditions based on climate change considerations given in the checklist. For this assessment, the following rating system was used:

- “High” rating: expected impacts of climate change on listed item pose a severe risk to regional operations in the future, including, impacts that greatly inhibit the ability of water management districts to deliver water supplies to users within the region.
- “Medium” rating: expected impacts of climate change on listed item pose a moderate risk to regional operations in the future, including, impacts that require management and planning changes in order to mitigate adverse effects.
- “Low” rating: expected impacts of climate change on listed item pose a low risk to regional operations in the future, including, impacts that may be mitigated through relatively simple planning or management changes, but are not critical to regional operations.
- “Not Applicable” (N/A) to the Region, or impacts that will not affect regional operations.

**Evaluate IRWM region’s vulnerabilities to climate change and potential adaptation responses based on vulnerabilities assessment in the DWR Climate Change Handbook for Regional Water Planning.**

**Table 13.1 IRWMP Climate Change Vulnerability Assessments**

<b>List No.<sup>1</sup></b>	<b>Checklist Item</b>	<b>Regional Conditions</b>	<b>Vul. Rating<sup>2</sup></b>
<b><i>I. Water Demand Assessment</i></b>			
I.A	Are there major industries that require cooling/process water in your planning region?	Currently, requirements for cooling/process water are insignificant in the Region.	Low
I.B	Does water use vary by more than 50% seasonally in parts of your region?	Yes. Water for irrigated agriculture is the predominant use of water in the Region. While annual water demands are fairly consistent from year to year, there is considerable seasonal variation, with the highest demands occurring in the summer and lowest demands in the winter. .	Medium
I.C	Are crops grown in your region climate-sensitive? Would shifts in daily heat patterns, such as long heat lingers before night-time cooling, be prohibitive for some crops?	All crops grown in the Region are climate sensitive to some extent. Modest shifts in heating and cooling patterns are likely to affect crop yield; however, significant shifts could affect the viability of continuing to grow certain crops.  Trends regarding accumulated winter chill were investigated by Baldocchi and Wong (2008) for climate stations located throughout the Central Valley. One station was located within the Region; it is a CIMIS station located near the City of Shafter (which is in the south-central portion of the Region). In contrast to many stations in other areas of the state, the record for this station did not evidence a negative (or adverse) trend with regard to chill hours; however, it did show a negative trend with regard to chilling-degree hours.	Medium
I.D	Do groundwater supplies in your region lack resiliency after drought years?	Groundwater levels will decline with a period of dry years. The resiliency of the Region’s groundwater resource is directly related to the reliability of imported surface water supplies since groundwater is used to meet demands that are not fulfilled by surface water supplies. To this extent, “resiliency” has been reduced.	High

<sup>1</sup> Numbers based on checklist shown in Section 4.3 of the ‘Climate Change Handbook for Regional Water Planning’ (DWR, 2011).

**Table 13.1 (Continued) IRWMP Climate Change Vulnerability Assessments**

List No.	Checklist Item	Regional Conditions	Vul. Rating
<b><i>I. Water Demand Assessment</i></b>			
I.E	Are water use curtailment measures effective in your region?	There has been a trend in the Region toward permanent crops, which has resulted in permanent crops accounting for 65% to 75% or more of the irrigated acreage within the Region. To this extent, the potential to curtail water use in any given year by fallowing has been reduced. Some districts have also initiated permanent demand reduction by purchasing and retiring land from irrigated agricultural uses. Water use efficiency improvements within a conjunctive use basin, overlying usable groundwater, may improve the effectiveness of water use; however, they do not curtail consumptive water use.	Medium
I.F	Are some in-stream flow requirements in your region either currently insufficient to support aquatic life, or occasionally unmet?	While there are no in-stream flow requirements within the Region, the surface water supplies which are available to the Region may be affected by such requirements at the sources of these supplies (SWP, CVP, and Kern River).	N/A
<b><i>II. Water Supply Assessment</i></b>			
II.A	Does a portion of the water supply in your region come from snowmelt?	Yes. All surface water inflows are primarily a function of snowmelt runoff; however, the snowmelt does not occur within the Region.	High
II.B	Does part of your region rely on water diverted from the Delta, imported from the Colorado River, or imported from other climate-sensitive systems outside your region?	Yes. Regional water supplies include water diverted from the Delta (both SWP and CVP water); the San Joaquin River (via the Friant Division of the CVP); and the Kern River (reference Section 3.3). Both the San Joaquin River and the Kern River have their watersheds in the Sierra Nevada Mountains, which have been identified as climate-sensitive.	High

<sup>1</sup> Numbers based on checklist shown in Section 4.3 of the ‘Climate Change Handbook for Regional Water Planning’ (DWR, 2011).

**Table 13.1 (Continued) IRWMP Climate Change Vulnerability Assessments**

List No.	Checklist Item	Regional Conditions	Vul. Rating
<b>II. Water Supply Assessment</b>			
II.C	Does part of your region rely on coastal aquifers? Has salt intrusion been a problem in the past?	No.	N/A
II.D	Would your region have difficulty in storing carryover surpluses from year to year?	There is limited carryover available for SWP water in San Luis Reservoir. Carryover of Kern River water in Isabella Reservoir is limited by the Reservoir’s flood control purpose and USACE Regulations. Carryover of CVP water in Millerton Reservoir is essentially non-existent. The most effective means of local regulation is through the use of available groundwater storage. The Region includes major water conveyance facilities, as well as significant in-lieu and direct recharge capabilities, which facilitate groundwater storage. There are opportunities to expand the Region’s groundwater storage capabilities.	High
II.E	Has your region faced a drought in the past during which it failed to meet local water demands?	No. Water demands have been met through the use of groundwater which, during drought, can result in significant declines in groundwater levels. To the extent that surface water supplies are reduced in the future (as a result of climate change and/or regulatory constraints), recharge will be reduced, which will affect the availability of groundwater for meeting local water demands. In addition, hardening of the Region’s demand (with an increased percentage of permanent crops) increases the likelihood of water supply deficiencies going forward.	High
II.F	Does your region have invasive species management issues at your facilities, along conveyance structure, or in habitat areas?	Invasive species issues are minimal in the Region, primarily consisting of algae growth in canals during times of low conveyance with low velocities or ponded water conditions.	Low

<sup>1</sup>Numbers based on checklist shown in Section 4.3 of the ‘Climate Change Handbook for Regional Water Planning’ (DWR, 2011).

**Table 13.1 (Continued) IRWMP Climate Change Vulnerability Assessments**

List No.	Checklist Item	Regional Conditions	Vul. Rating
<b>III. Water Quality Assessment</b>			
III.A	Are increased wildfires a threat in your region? If so, does your region include reservoirs with fire-susceptible vegetation nearby which could pose a water quality concern from increased erosion?	Wildfires are not a threat within the Region; however, wildfires are a threat in the Kern River watershed. Wildfires and subsequent erosion upstream of Isabella Reservoir would likely be mitigated by detention in the reservoir. Wildfires and subsequent erosion downstream of the reservoir would have greater potential to affect the irrigation operations in the Region, particularly those relying on micro-irrigation methods. Depending on timing, direct recharge of groundwater in spreading ponds could also be adversely impacted. There would be no threat to M&I uses within the Region since all such uses are met with groundwater.	Low
III.B	Does part of your region rely on surface water bodies with current or recurrent water quality issues related to eutrophication, such as low dissolved oxygen or algal blooms? Are there other water quality constituents potentially exacerbated by climate change?	Some local and regional canals seasonally have algae blooms that require maintenance, including minimal treatment or cleanup efforts. Algae blooms may become more frequent with climate change as a result of increased temperatures in the Region and less water moving through the canals.	Low
III.C	Are seasonal flows decreasing for some water-bodies in your region? If so, are the reduced low flows limiting the water-bodies' assimilative capacity?	Poso Creek is the only "water body" in the Region with seasonal flows; however, whether seasonal flows are decreasing is currently unknown, although a greater investigation into this is currently being undertaken and will be included in future Updates and in the 2020 GSPs corresponding to this Region.	N/A
III.D	Are there beneficial uses designated for some water bodies in your region that cannot always be met due to water quality issues?	No.	N/A
III.E	Does part of your region currently observe water quality shifts during rain events that impact treatment facility operation?	No. M&I uses in the Region are supplied by groundwater pumping and surface water supplies are not treated for irrigation use.	N/A

<sup>1</sup>Numbers based on checklist shown in Section 4.3 of the 'Climate Change Handbook for Regional Water Planning' (DWR, 2011).



**Table 13.1 (Continued) IRWMP Climate Change Vulnerability Assessments**

List No.	Checklist Item	Regional Conditions	Vul. Rating
<i>IV. Sea Level Rise Assessment</i>			
IV.A	Has coastal erosion already been observed in your region?	The Poso Creek Region is located in the Southern San Joaquin Valley, and the concerns regarding coastal regions are not applicable.	N/A
IV.B	Are there coastal structures, such as levees or breakwaters, in your region?		N/A
IV.C	Is there significant coastal infrastructure, such as residences, recreation, water and wastewater treatment, tourism, and transportation at less than six feet above mean sea level in your region?		N/A
IV.D	Are there climate-sensitive low-lying coastal habitats in your region?		N/A
IV.E	Are there areas in your region that currently flood during high tides or storm surges?		N/A
IV.F	Do tidal gauges along the coastal parts of your region show an increase over the past several decades?		N/A

<sup>1</sup> Numbers based on checklist shown in Section 4.3 of the ‘Climate Change Handbook for Regional Water Planning’ (DWR, 2011).

**Table 13.1 (Continued) IRWMP Climate Change Vulnerability Assessments**

List No.	Checklist Item	Regional Conditions	Vul. Rating
<i>V. Flooding Assessment</i>			
V.A	Does critical infrastructure in your region lie within the 200-year floodplain?	Although flows in Poso Creek are infrequent, flooding of adjacent lands has occurred from time to time. The Poso Creek floodplain traverses the northern portion of the Region from east to west. Most of the area within the floodplain consists of irrigated agriculture; however, a reach of State Highway 99 and a portion of the City of McFarland are also included. Highway 99 is a major north-south transportation corridor, the disruption of which would have public safety, as well as economic, implications.	Medium
V.B	Does part of your region lie within the Sacramento-San Joaquin Drainage District?	No.	N/A
V.C	Does aging critical flood protection infrastructure exist in your region?	No. As mentioned in Section 3.5, storage restrictions have been in place on Isabella Reservoir since 2006 and will remain in place until dam safety concerns are adequately addressed. While Isabella Reservoir does not present a flood control issue for the Region, it is a water supply issue, inasmuch as it regulates the delivery of Kern River water to the Region. Members of the RWMG have actively encouraged the USACE to expedite the “fix” for Isabella Dam deficiencies.	Medium
V.D	Have flood control facilities (such as impoundment structures) been insufficient in the past?	While there are not any flood control impoundment structures in the Region, investigations have been conducted in the past regarding the feasibility of constructing a dam on Poso Creek (which has yet to pass the benefit-cost test).	Low
V.E	Are wildfires a concern in parts of your region?	As noted in III.A (above), wildfires are not a concern in the Region; however, wildfires are a concern in the watersheds that provide the Region with its surface water supplies.	Low

<sup>1</sup>Numbers based on checklist shown in Section 4.3 of the ‘Climate Change Handbook for Regional Water Planning’ (DWR, 2011).

**Table 13.1 (Continued) IRWMP Climate Change Vulnerability Assessments**

<b>List No.</b>	<b>Checklist Item</b>	<b>Regional Conditions</b>	<b>Vul. Rating</b>
<b><i>VI. Ecosystem and Habitat Vulnerability Assessment</i></b>			
VI.A	Does your region include inland or coastal aquatic habitats vulnerable to erosion and sedimentation issues?	Coastal aquatic habitats are not applicable to the Region. The potential for erosion or sedimentation exists along the channel of Poso Creek. Significant flow in Poso Creek is very infrequent.	Low
VI.B	Does your region include estuarine habitats which rely on seasonal freshwater flow patterns?	No.	Low
VI.C	Do climate-sensitive fauna or flora populations live in your region?	No.	Low
VI.D	Do endangered or threatened species exist in your region? Are changes in species distribution already being observed in parts of your region?	Yes. They consist of San Joaquin Kit Fox, Tipton Kangaroo Rat, and San Joaquin Woolly Threads. Whether or not changes in species distribution have occurred is unknown. In this regard, it is noted that the IRWM Group supports the management efforts for endangered and threatened species led by the Tulare Basin Wildlife Partners, who actively monitor species distribution and habitat changes in the Region.	Medium
VI.E	Does the region rely on aquatic or water-dependent habitats for recreation or other economic activities?	Recreational water use in the Region is limited to duck clubs which rely on seasonal flooding of ponds which have been developed for that purpose.	Low
VI.F	Are there rivers in your region with quantified environmental flow requirements or known water quality/quantity stressors to aquatic life?	No.	N/A
VI.G	Do estuaries, coastal dunes, wetlands, marshes, or exposed beaches exist in your region? If so, are coastal storms possible/frequent in your region?	The Kern National Wildlife Refuge is located within the Region and manages some wetlands; however, coast storms are not possible in the Region, owing to its location in the southern San Joaquin Valley.	N/A

<sup>1</sup> Numbers based on checklist shown in Section 4.3 of the 'Climate Change Handbook for Regional Water Planning' (DWR, 2011).

**Table 13.1 (Continued) IRWMP Climate Change Vulnerability Assessments**

List No. <sup>1</sup>	Checklist Item	Regional Conditions	Vul. Rating
<b><i>VII. Hydropower Reliance Assessment</i></b>			
VI.H	Does your region include one or more of the habitats described in the Endangered Species Coalition’s Top 10 habitats vulnerable to climate change?	No. The Central Valley of California, where the Poso Creek Region is located, is not listed as one of the ‘Top 10’ habitats vulnerable to Climate Change according to the ‘It’s Getting Hot Out There: Top 10 Places to Save for Endangered Species in a Warming World’ Report (Endangered Species Coalition, 2010).	N/A
VI.I	Are there areas of fragmented estuarine, aquatic, or wetland wildlife habitat within your region? Are there movement corridors for species to naturally migrate? Is there infrastructure projects planned that might preclude species movement?	The Region includes the Kern National Wildlife Refuge, the Goose Lake bed, temporary wetlands in the form of duck clubs, and the channel of Poso Creek. Poso Creek traverses the Region from east to west and connects with the Refuge. The channel of Poso Creek provides an east-west movement corridor for wildlife, which extends from the foothills in the east to the trough of the San Joaquin Valley in the west. Flow in this reach of Poso Creek is infrequent. While infrastructure projects are planned which involve Poso Creek, they would not adversely affect the use of Poso Creek as a wildlife movement corridor. In particular, maintenance of the channel’s flow carrying capacity is compatible with its use as a movement corridor. The RWMG has planned some projects and programs, pursuant to the Measurable Objectives (see Section 4.5, objective “I”) to improve existing facilities while not changing the movement corridors.	Low
VII.A	Is hydropower a source of electricity in your region?	PG&E and SCE provide electrical service in the Region, and their sources of electricity are many and varied. As of 2012, SCE’s electrical generation portfolio included less than 10% hydropower, while PG&E’s was a little more than 10%, both outside the Region. Hydropower generation within the Region is very minor and is incidental to the operation of irrigation conveyance and distribution facilities.	Low

<sup>1</sup>Numbers based on checklist shown in Section 4.3 of the ‘Climate Change Handbook for Regional Water Planning’ (DWR, 2011).

**Table 13.1 (Continued) IRWMP Climate Change Vulnerability Assessments**

List No. <sup>1</sup>	Checklist Item	Regional Conditions	Vul. Rating
<i>VII. Hydropower Reliance Assessment</i>			
VII.B	Are energy needs in your region expected to increase in the future? If so, are there future plans for hydropower generation facilities or conditions for hydropower generation in your region?	<p>It is reasonable to expect that energy needs in the Region will increase in the future as a result of several factors, which include changes in land use from agricultural uses to urban uses; increases in groundwater pumping with reductions in historically available surface water supplies (i.e., as a result of climate-induced changes in hydrology and/or increased regulatory constraints on surface water supplies imported to the Region); and increases in groundwater pumping to satisfy higher ET requirements for irrigated agriculture (i.e., to the extent that “climate change” results in higher ET).</p> <p>There is one existing small hydropower facility and there is one under development. The existing facility is driven by imported SWP supplies and the same will be true of the facility which is under development. The combined capacity will be very small compared to the energy requirements of the Region, particularly during “dry” years. Future plans for hydropower generation facilities in the Region are unknown; however, any such plans would be limited to small hydropower which is incidental to the operation of irrigation conveyance and distribution systems. In this regard, based on currently available technology, solar generation is more likely than small hydropower.</p>	Low

<sup>1</sup> Numbers based on checklist shown in Section 4.3 of the ‘Climate Change Handbook for Regional Water Planning’ (DWR, 2011).

Table 13.2 summarizes the results of the vulnerability assessment presented in Table 13.1. The seven sections of the assessment are listed in order of vulnerability, from highest to lowest.

**Table 13.2 IRWMP Climate Change Vulnerability Assessment Score-Sheet**

Section No. <sup>1</sup>	Section Title	Vulnerability Rating			
		High	Medium	Low	N/A
II	Water Supply Assessment	4	0	1	1
I	Water Demand Assessment	1	3	1	1
V	Flooding Assessment	0	2	2	1
VI	Ecosystem and Habitat Vulnerability Assessment	0	1	4	2
III	Water Quality Assessment	0	0	2	3
VII	Hydropower Reliance Assessment	0	0	3	1
IV	Sea Level Rise Assessment	0	0	0	6
<b>Total Climate Change Assessment Score</b>		<b>5</b>	<b>6</b>	<b>13</b>	<b>15</b>

<sup>1</sup> Numbers based on checklist shown in Section 4.3 of the ‘Climate Change Handbook for Regional Water Planning’ (DWR, 2011).

Based on the vulnerability assessment summarized in Table 13.2, “Water Supply” and “Water Demand” appear to have the highest level of vulnerability to potential Climate Change impacts in the Region. This confirms the projected outlook for the Region presented in Sections 13.1 and 13.2, respectively. This emphasis is also evident by the defined “Primary Regional Goals” identified in Section 4.4, and the basis by which projects and programs are assessed as described in Section 7.3. The remaining sections assessed in Table 13.1, while important, do not pose as much of a projected risk to regional water resources operations or management efforts.

### 13.4 Mitigation of Greenhouse Gas Emissions

As mentioned above, many scientists believe that one of the primary drivers behind the worsening of climate change effects is the emission of greenhouse gases (GHG) that absorb and emit infrared radiation, effectively trapping heat in the Earth’s atmosphere. Under Assembly Bill 32 (AB 32), GHGs are defined as carbon dioxide, methane, nitrous oxide, sulfur hexafluoride, hydrofluorocarbons, and perfluorocarbons. Anthropogenic releases of these GHGs from the burning of fossil fuels have presumably accelerated the rate of natural climate change. Along with the extensive clearing of native forests, the entrapment of GHGs in the atmosphere has progressively increased the global temperature to levels that are expected to exceed historical patterns as early as the mid-21<sup>st</sup> century (Camilo *et al.*, 2013).

While the RWMG is not responsible for air quality management or GHG measurement in the Region, they are able to assist in the mitigation of GHG emissions by selecting and promoting projects and programs that help to reduce regional emissions. Projects and programs are emphasized on the direct and noticeable impacts to water supplies and demands in the Region, which is identified in the Primary Regional Goals; however, all other things being equal, the RWMG would defer to projects that also result in a reduction to GHG emissions or contribute to climate change response strategies. Accordingly, the RWMG considers the mitigation of GHG emissions as part of the Measurable Objectives, as outlined in Section 4.5, under the promotion of environmental conservation, see Objective “I”, and follows the assessment through the submission and review process for projects and programs shown in Section 7.3 under the consistency with IRWM Measurable Objectives. For example, the RWMG may review a water conservation measure based on the ability to reduce energy demands to pump and convey water supplies which, in effect reduces an amount of GHGs emitted from those processes. Another example includes the expansion of environmental habitats areas in the Region, or retirement of agricultural land, which may be used to sequester carbon via the eventual growth of native vegetation. The RWMG expects project and program submissions to clearly, and in some instances quantitatively, explain the benefits towards GHG mitigation or Climate Change preparedness in submitted PDCF’s (reference Section 5.1).

Regarding structural project implementation, the California Environmental Quality Act (CEQA) requires the calculation of GHG emissions from the construction and operation of newly developed projects (post July 2012). Emissions must be calculated using the California Emissions Estimator Model, which quantifies potential pollutants and GHG emissions based on design data. Once a project is selected for possible implementation, the RWMG requires this model be used to be considered for funding and compliant with CEQA requirements.

### **13.5 Climate Change Response and Monitoring Efforts**

The RWMG Participants have taken numerous steps to adapt to the projected impacts of climate change effects on the Region. As noted in Table 13.2, the Region appears most vulnerable regarding maintaining adequate water supplies to meet demand. As such, many of these measures have been focused on management and planning efforts that work to better prepare the regional water users in the event of multiple potential impacts, as opposed to focusing on a single specific impact, such as, the impact of temperature increase on water demand and water supplies.

Note that, as discussed in previous sections of this 2019 Update, the effects of sea level rise (SLR) on water supply conditions are considered negligible due to the Region’s inland

location. However, subsidence is expected to worsen, and the Region is actively engaged in creating projects to mitigate these effects.

Regarding feasibility, in some cases, adaptations to water management in the Region, are not easily made and may be largely out of the RWMG's control. For instance, conjunctive use is practiced in the Region by the irrigation interests, which effectively means that groundwater is utilized to meet irrigation water requirements when supplemental surface water supplies are not available. The production and delivery of groundwater requires considerably more energy (kWh) than the delivery of surface water. Groundwater pumping lifts range from 250 to 400 feet or more in some parts of the Region, and groundwater plays an important role in terms of water supplies as described in Section 3.4. Accordingly, with any reduction in the reliability of surface water supplies delivered into the Region, there is a corresponding increase in the use of energy to deliver water, which typically results in an increase in the GHG emissions attributable to energy generation.

The following strategies were deemed the most practical and effective for climate change preparation in the Region, while also providing measurable benefits to current water management practices:

- Expand in-lieu service areas in the Region, by expanding water conveyance to lands which are currently dependent solely on groundwater supplies (i.e., reduce dependency on groundwater basin during “wetter” periods).
- Improve agricultural and urban water use efficiency.
- Expand groundwater recharge and banking efforts through expansion of spreading pond acreage to capture surplus wet-period water supplies and thereby help to maintain groundwater levels.
- Encourage changes in regional crop varieties that are more resistant to climate change.

The RWMG emphasizes these strategies not only in response to climate, but also to cope with significant surface water supply deficiencies that have already faced the Region. The Regional Goals and Measurable Objectives stated in this Plan are based on the enhancement of water management in the Region, which directly addresses water supply and demand impacts due to fluctuations in hydrologic conditions, including those potential impacts due to climate change. The selection of projects and programs that accomplish the goals and objectives of the Plan is based on adherence to the RWMG's water management efforts, with consideration of climate change affects, as discussed previously in Section 5.0. Figure 13.1 illustrates how the RWMG addresses climate change in the context of IRWM planning efforts.



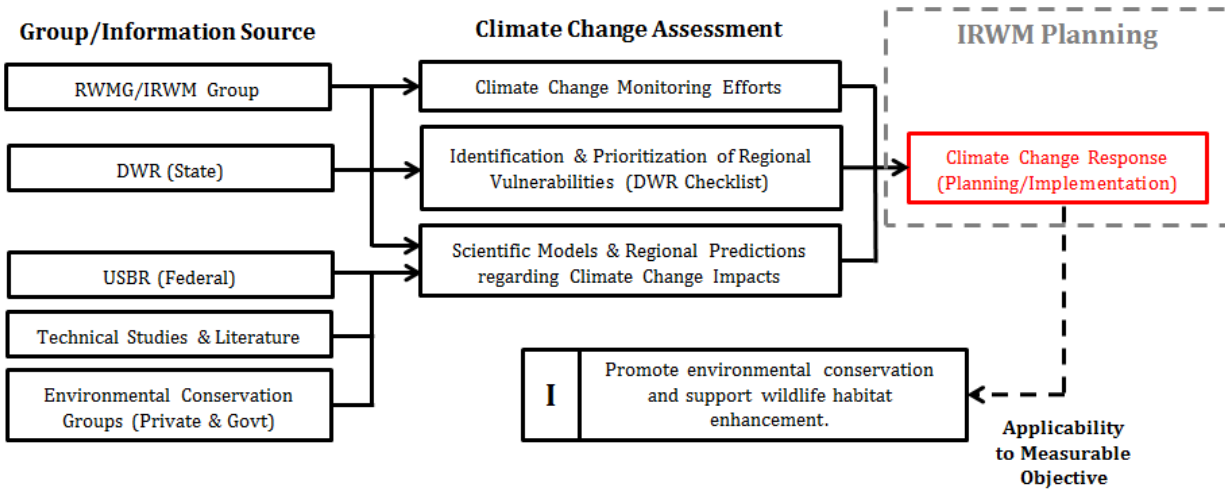

**Figure 13.1** Regional Climate Change Planning Structure

Key indicators of climate change will be monitored with regard to changes in the hydrology of surface water sources available to the Region, as well as changing conditions within the Region. The RWMG will work with the DWR to continue to provide adequate surface water supplies to meet regional changing conditions. The districts in the Region have little to no control over the reliability and availability of its imported water supplies; accordingly, efforts are expected to remain focused on maximizing the use of the imported water supplies, whenever they are available. This has been and will continue to be accomplished through the conjunctive management of both surface water and groundwater resources. However, as previously noted, any reduction in surface water supplies can be expected to increase the use of energy in the Region, which would result in an assumed increase in GHG emissions at the source of the increased generation of electrical energy.

The science behind climate change, and the models and tools used to measure and predict specific impacts, are constantly changing. As a result, the RWMG will actively monitor climate change literature, legislation, and modeling results and will update planning and management efforts accordingly.

## 14.0 References

The following is a list of references cited throughout the Plan, in alphabetical order. These references, in particular, the cited sections, subsections, or quoted text are available upon request.

Baldocchi D; Wong, S., 2008. “Accumulated Winter Chill is Decreasing in the Fruit Growing Regions of California.” *Climate Change* 87: S153-S166.

Bay Delta Conservation Plan (BDCP). California Department of Water Resources, US Bureau of Reclamation (Mid-Pacific Region), State and Federal Contractors Water Agency, Metropolitan Water District of Southern California, Kern County Water Agency, State Water Project Contractors Authority, San Luis & Delta-Mendota Water Authority, Westlands Water District, Santa Clara Valley Water District. December 2011. ‘Amended Memorandum of Agreement Regarding Collaboration on Planning, Design and Environmental Compliance for the Delta Habitat Conservation and Conveyance Program in Connection with the California Bay Delta Conservation Plan.’

California Department of Water Resources. October 2013. “California Water Plan: Update 2013.” Public Review Draft.

California Department of Water Resources. November 2012. “Integrated Regional Water Management: Proposition 84 and 1E Guidelines.”

California Department of Water Resources (Bay-Delta). June 2012. “The State Water Project: Draft Delivery Reliability Report 2013.”

California Department of Water Resources, US Environmental Protection Agency, US Army Corps of Engineers. November 2011. “Climate Change Handbook for Regional Water Planning.”

California Department of Water Resources, State Water Resources Control Board. June 2007. “Integrated Regional water Management Grant Program Guidelines: Proposal Solicitation Packages, Round 2.”

California Department of Water Resources (Bay-Delta). April 2006. “The State Water Project Delivery Reliability Report 2005.”

California Department of Water Resources, State Water Resources Control Board. November 2004. “Integrated Regional Water Management Grant Program Guidelines: Proposition 50, Chapter 8.”

California Department of Water Resources (Bay-Delta). December 2003. “A Strategic Review of CALSIM II and its Use for Water Planning, Management, and Operations in Central California.”

- California Department of Water Resources. October 2003. "California's Groundwater: Bulletin 118 – Update 2003."
- California Department of Water Resources, US Bureau of Reclamation (Mid-Pacific Region). August 2001. "A Memorandum Report on the Application of CALSIM II Model at 2020 Level-of-Development."
- California State Water Resources Control Board. February 2010. "20x2020 Water Conservation Plan."
- Camilo, Mora; Frazier, Abby G.; Longman, Ryan J.; Dacks, Rachel S.; Walton, Maya M.; Tong, Eric J.; Sanchez, Joseph J.; Kaiser, Lauren R.; Stender, Yuko O.; Anderson, James M.; Ambrosino, Christine M.; Fernandez-Silva, Iria; Giuseffi, Louise M.; Giambelluca, Thomas W. October 2013. "The Projected Timing of Climate Departure from Recent Variability." *Nature* 502: 183-187.
- Cawelo Water District. 2014. "Agricultural Water Management Plan." Public Review Draft.
- Cawelo Water District. 2010. "Water Conservation Plan." Submitted to the US Bureau of Reclamation (Mid-Pacific Region).
- Cawelo Water District. 2007. "Groundwater Management Plan." Submitted to the California Department of Water Resources.
- Delano-Earlimart Irrigation District. 2013. "Water Conservation Plan." Submitted to the US Bureau of Reclamation (Mid-Pacific Region).
- Delano-Earlimart Irrigation District. 2007. "Groundwater Management Plan." Submitted to the California Department of Water Resources.
- Chung et al. California Department of Water Resources. 2009. "Using Future Climate Projections to Support Water Resources Decision Making in California."
- City of Bakersfield, County of Kern, Metropolitan Bakersfield Habitat Conservation Plan Steering Committee. April 1994. "Metropolitan Bakersfield Habitat Conservation Plan (HCP)."
- City of Delano. 2010. "Urban Water Management Plan." Submitted to the California Department of Water Resources.
- City of Delano. 2005. "Delano General Plan." Submitted to the City of Delano General Council.
- City of McFarland. 2011. "McFarland General Plan." Submitted to the City of McFarland General Council.
- City of Shafter. 2010. "Urban Water Management Plan." Submitted to the California Department of Water Resources.
- City of Shafter. 2005. "Shafter General Plan." Submitted to the City of Shafter General Council.

- City of Wasco. 2010. "Urban Water Management Plan." Submitted to the California Department of Water Resources.
- City of Wasco. 2002. "Wasco General Plan." Submitted to the City of Wasco General Council.
- County of Kern. 2009. "Kern County General Plan." Submitted to the Kern Council of Governments.
- Endangered Species Coalition. 2010. "It's Getting Hot Out There: Top 10 Places to Save for Endangered Species in a Warming World."
- Hanson, R.T.; Flint, A.L.; Flint, L.E.; Faunt, C.C.; Schmid, W.; Dettinger, M.D.; Leake, S.A.; and Cayan, D.R., 2010. "Integrated Simulation of Consumptive Use and Land Subsidence in the Central Valley, California, for the Past and for a Future Subject to Urbanization and Climate Change". Proceedings of the Eighth International Symposium on Land Subsidence (EISOLS).
- Kern Integrated Regional Water Management Plan. 2011. "Tulare Lake Basin Portion of Kern County Integrated Regional Water Management Plan (Kern IRWMP)."
- Kern Council of Governments. 2008. "Kern Regional Blueprint Program: Kern Blueprint Final Report."
- Kern County Department of Agricultural and Measurement Standards. 2013. "2012 Kern County Agricultural Crop Report."
- Kern County Planning Department. December 2006. "Kern County Valley Floor Habitat Conservation Plan (HCP)."
- Kern County Water Agency. February 1983-2014. "Water Supply Report." Annual Publication released by Agency, various reports used for development of Plan.
- Kern River Watershed Coalition Authority. September 2013. "Order R5-2013-0120: Waste Discharge Requirements General Order for Growers within the Tulare Lake Basin Area that are Members of a Third-Party Group." Submitted to the California Regional Water Quality Control Board (Central Valley Region).
- Kern-Tulare Water District. 2013. "Water Conservation Plan." Submitted to the US Bureau of Reclamation (Mid-Pacific Region).
- Kern-Tulare Water District. 2012. "Groundwater Management Plan." Submitted to the California Department of Water Resources.
- Luedeling, E; Zhang, M; Girvetz, E.H., July 2009. "Climatic Changes Lead to Declining Winter Chill for Fruit and Nut Trees in California during 1950-2099". PLoS ONE 4(7).
- MBK Engineers. April 2007. "CVC CALSIM Study 2005A01A". E-mail correspondence with GEI Consultants, Inc.

- North Kern Water Storage District. 2014. “Agricultural Water Management Plan.” Public Review Draft.
- North Kern Water Storage District. 2012. “Groundwater Management Plan.” Submitted to the California Department of Water Resources.
- Poso Creek Regional Water Management Group. March 2013. “Implementation Grant Proposal for the Poso Creek Integrated Regional Water Management Plan.” Application for Proposition 84, Round 2, Implementation Grant.
- Poso Creek Regional Water Management Group. May 2010. “Poso Creek Integrated Regional Water Management Plan Region: Memorandum of Understanding.”
- Poso Creek Regional Water Management Group. April 2009. “Regional Acceptance Process (RAP): Component of the IRWM Program Guidelines.”
- Poso Creek Regional Water Management Group. July 2007. “Poso Creek Integrated Regional Water Management Plan (IRWMP).”
- Semitropic Water Storage District. 2013. “Agricultural Water Management Plan.” Submitted to the California Department of Water Resources.
- Semitropic Water Storage District. 2012. “Groundwater Management Plan.” Submitted to the California Department of Water Resources.
- Semitropic Water Storage District. November 2010. “Initial Study for Groundwater Banking and Exchanges within the Poso Creek Plan Area.”
- Shafter-Wasco Irrigation District. 2013. “Water Conservation Plan.” Submitted to the US Bureau of Reclamation (Mid-Pacific Region).
- Shafter-Wasco Irrigation District. 2007. “Groundwater Management Plan.” Submitted to the California Department of Water Resources.
- Southern San Joaquin Municipal Utility District. 2013. “Water Conservation Plan.” Submitted to the US Bureau of Reclamation (Mid-Pacific Region).
- Steiner, Daniel B. February 2007. “Water Supply Projected Monthly Availability for CVP-Friant Supplies under terms of the San Joaquin River Settlement for the Period Extending from 1922 to 2004: Delano-Earlimart Irrigation District Data.” Draft Memorandum.
- Steiner, Daniel B. February 2007. “Water Supply Projected Monthly Availability for CVP-Friant Supplies under terms of the San Joaquin River Settlement for the Period Extending from 1922 to 2004: Southern San Joaquin Municipal Utility District Data.” Draft Memorandum.

- Steiner, Daniel B. February 2007. “Water Supply Projected Monthly Availability for CVP-Friant Supplies under terms of the San Joaquin River Settlement for the Period Extending from 1922 to 2004: Shafter-Wasco Irrigation District Data.” Draft Memorandum.
- US Bureau of Reclamation (Mid-Pacific Region). February 2013. “Central Valley Project Water Plan 2013.”
- US Bureau of Reclamation (Mid-Pacific Region). October 1992. “Water Supply Report for the Friant Division of the Central Valley Project (CVP).”
- US Fish and Wildlife Service. 1992. “Central Valley Project Improvement Act (CVPIA).”
- United States Geological Survey. Fact Sheet 2009-3074. September 2009. “Effects of Climate Variability and Change on Groundwater Resources in the United States”.
- Water Resources Research, Vol. 48, 2012. “A Method for Physically Based Model Analysis of Conjunctive Use in Response to Potential Climate Change”.

## **APPENDIX A**

### **Poso Creek Integrated Regional Water Management (IRWM) Group Project and Program Lists**

#### **APPENDIX A1**

##### **Project and Program Report List (Historical) and IRWM Report Card**

#### **APPENDIX A2**

##### **Plan Project and Program List**

## **APPENDIX A1**

### **Project and Program Report List (Historical) and IRWM Report Card**



# Poso Creek IRWM Project and Program Report List

Page 1 of 5

Category (for historical reference):

1. Planning and IRWM Compliance
2. Community, Industrial, and Environmental-Specific
3. Regional Projects and Programs

Year(s)	Activity Title	Activity Type	Category	Purpose	Applicant	Measurable Objective(s)*	IRWM-Based Support	Applicant(s) Share	Applicant %	State Grant Share	State Grant %	Federal Grant Share	Federal Grant %	Total Cost(s)
2006-2007	Poso Creek IRWM Plan	Program (Planning)	1	Prop 50 Planning	IRWM Group	Objectives Defined		\$214,600	30%	\$499,435	70%	\$0	0%	\$714,035
2007	Implementation Grant App	Program (Grant App)	1	Prop 50 Planning	IRWM Group	B, C, E, F, K, L		\$30,000	100%	\$0	0%	\$0	0%	\$30,000
2007	SOR Planning Grant App	Program (Grant App)	1	Reclamation Programs	IRWM Group	B, E, F, I, K, L		\$25,000	100%	\$0	0%	\$0	0%	\$25,000
2007	Groundwater Monitoring Improvement Project	Project	3	Local Groundwater Assistance	Semitropic	B, F, G, K, L, M		\$0	0%	\$250,000	100%	\$0	0%	\$250,000
2008-2010	Institutional Agreements	Program (Planning)	3	System Optimization Review	IRWM Group	B, E, F, I, K, L		\$0	0%	\$0	0%	\$300,000	100%	\$300,000
2009	Governance MOU Development	Program (Planning)	1	IRWM Guidelines	RWVG	M, N		\$3,600	100%	\$0	0%	\$0	0%	\$3,600
2009	Region Acceptance Process - I	Program (Planning)	1	IRWM Guidelines	IRWM Group	E, F, K, L, M, N		\$57,343	100%	\$0	0%	\$0	0%	\$57,343
2009	RWVG Activity and Regional GW Bank CEQA	Program (Planning)	3	Groundwater Banking/Permitting	IRWM Group	B, C, E, F, K, L		\$64,879	100%	\$0	0%	\$0	0%	\$64,879
2010	Governance MOU Review	Program (Planning)	1	IRWM Guidelines	RWVG	M, N		\$2,888	100%	\$0	0%	\$0	0%	\$2,888
2010	SOR Application	Program (Planning)	1	Reclamation Programs	IRWM Group	E, I, K, L		\$19,335	100%	\$0	0%	\$0	0%	\$19,335
2010	RWVG Activity -Regional GW Bank Env Doc and RAP II	Program (Planning)	3	IRWM Guidelines	IRWM Group	C, D, E, G, K, L, M, N		\$121,234	100%	\$0	0%	\$0	0%	\$121,234
2010	Regional GW Bank EA	Program (Planning)	3	Groundwater Banking/Permitting	RWVG	C, D, E, G, K, L, M, N		\$19,163	100%	\$0	0%	\$0	0%	\$19,163
2010 - 2011	Rural Water Supply Application	Program (Grant App)	2	Reclamation Programs	IRWM Group	I, K, L		\$16,482	100%	\$0	0%	\$0	0%	\$16,482
2010 - 2011	Prop 84, Rnd1 Imp App	Program (Grant App)	1	Prop 84 Planning	IRWM Group	All Objectives		\$148,760	100%	\$0	0%	\$0	0%	\$148,760
2010 - 2011	Urban Water Management Plans <sup>1</sup>	Program (Planning)	2	DWR Requirement	Cities of Delano, Shafter, and Wasco	E, F, G, J, M, N		\$100,000	100%	\$0	0%	\$0	0%	\$100,000
2011	RWVG Activity	Program (Planning)	1	IRWM Guidelines	IRWM Group	B, C, D, E, J, K, L, M, N		\$39,683	100%	\$0	0%	\$0	0%	\$39,683
2012	Regional GW Bank EA	Program (Planning)	3	Groundwater Banking/Permitting	IRWM Group	C, D, E, G, K, L, M, N		\$21,000	100%	\$0	0%	\$0	0%	\$21,000
2012	RWVG Activity	Program (Planning)	1	IRWM Guidelines	RWVG	B, C, D, E, J, K, L, M, N		\$9,560	100%	\$0	0%	\$0	0%	\$9,560
2012	Planning Grant App	Program (Grant App)	1	Prop 84 Planning	IRWM Group	All Objectives		\$26,057	100%	\$0	0%	\$0	0%	\$26,057
2012	Regional GW Bank EA	Program (Planning)	3	Groundwater Banking/Permitting	RWVG	C, D, E, G, K, L, M, N		\$1,625	100%	\$0	0%	\$0	0%	\$1,625
2012	LGA Grant to North Kern	Program (Planning)	3	Local Groundwater Assistance	IRWM Group	B, F, K, L, M		\$25,000	11%	\$200,000	89%	\$0	0%	\$225,000
2012	CASGEM <sup>1</sup>	Program	1	DWR Requirement	RWVG	B, F, G, K, L, M		\$60,000	100%	\$0	0%	\$0	0%	\$60,000
2013	RWVG Activity	Program (Planning)	1	IRWM Guidelines	RWVG	B, C, D, E, J, K, L, M, N		\$21,374	100%	\$0	0%	\$0	0%	\$21,374
2013	Prop 84 Plan Update Prep	Program (Planning)	1	Prop 84 Planning	IRWM Group	Objectives Defined		\$28,687	100%	\$0	0%	\$0	0%	\$28,687
2013	Poso Imp Rnd2 App	Program (Grant App)	1	Prop 84 Planning	IRWM Group	All Objectives		\$50,000	100%	\$0	0%	\$0	0%	\$50,000

<sup>1</sup> Activity uses estimated figures based on type and similarities to previous activities.

<sup>2</sup> Information for activity not yet obtained from applicant.

\* Measurable Objectives from Plan applied to historical projects and programs retroactively.

**Poso Creek IRWM Project and Program Report List**

Category (for historical reference):

- 1. Planning and IRWM Compliance
- 2. Community, Industrial, and Environmental-Specific
- 3. Regional Projects and Programs

Year(s)	Activity Title	Activity Type	Category	Purpose	Applicant	Measurable Objective(s)*	IRWM-Based Support	Applicant(s) Share	Applicant %	State Grant Share	State Grant %	Federal Grant Share	Federal Grant %	Total Cost(s)
2013	SJR Rest - Madera Ave Intertie App	Program (Grant App)	3	Reclamation Programs	Shafter-Wasco	C, D, E, G, H, K, L		\$38,231	100%	\$0	0%	\$0	0%	\$38,231
2013 - 2014	Ag Water Management Plans <sup>1</sup>	Program (Planning)	1	DWR Requirement	Semitropic, North Kern, and Cawelo	E, F, G, I, M, N		\$60,000	38%	\$100,000	63%	\$0	0%	\$160,000
2011 - 2015	Ag Water Conservation Plans <sup>1</sup>	Program (Planning)	1	Reclamation Programs	Kern-Tulare and Shafter-Wasco	E, F, G, I, M, N		\$30,000	100%	\$0	0%	\$0	0%	\$30,000
2014	Prop 84 Plan Update <sup>1</sup>	Program (Planning)	1	Prop 84 Planning	IRWM Group	Objectives Defined		\$164,755	100%	\$0	0%	\$0	0%	\$164,755
2010	Wastewater Treatment Plant Improvements in Buttonwillow	Project	2	DAC Assistance	Community of Buttonwillow	G, J, K, L		\$722,012	25%	\$2,000,000	70%	\$144,800	5%	\$2,866,812
2011	Extend Shafter Wastewater Collection System to North Shafter	Project	2	DAC Assistance	Community of North Shafter	G, J, K, L		\$0	0%	\$1,925,000	100%	\$0	0%	\$1,925,000
2011	Maple School Water Consolidation	Project	2	DAC Assistance	Maple School District	G, J, K, L		\$0	0%	\$551,113	100%	\$0	0%	\$551,113
2013	Habitat Improvement on Pond-Poso Spreading Basins	Project	2	General Resource Stewardship	Semitropic	I, K, L	Direct	\$9,192	59%	\$6,445	41%	\$0	0%	\$15,637
2013	DAC Feasibility Level Study - Assessment	Program (Planning)	2	DAC Assistance	Community of Allensworth	J, K, L	Direct	\$0	0%	\$45,531	100%	\$0	0%	\$45,531
2013	DAC Feasibility Level Study - Assessment and Design	Program (Planning)	2	DAC Assistance	Lost Hills Utility District	J, K, L	Direct	\$0	0%	\$75,000	100%	\$0	0%	\$75,000
2013	Consolidation of Bishop Acres into City of Shafter Water Supply System	Project	2	DAC Assistance	Community of Bishop Acres	G, J, K, L	Direct	\$30,000	7%	\$431,344	93%	\$0	0%	\$461,344
2013	North Shafter Sewer Service Connections	Project	2	DAC Assistance	Community of North Shafter	G, J, K, L	Direct	\$23,000	5%	\$481,900	95%	\$0	0%	\$504,900
2011 - 2013	On-Farm Mobile Lab, Water use-Efficiency Services	Project	2	Water Conservation	North West Kern RCD	C, E, K, L	Direct	\$154,000	65%	\$82,400	35%	\$0	0%	\$236,400
2013	Meter Installation in DAC Service Area	Project	2	DAC Assistance	City of Shafter	J, K, L, M	Direct	\$50,100	22%	\$174,856	78%	\$0	0%	\$224,956
2006	Friant-Kern Turnout No. 1 & Deep Wells	Project	3	Conveyance/Infrastructure	North Kern	C, D, E, G, K, L		\$933,000	45%	\$1,131,000	55%	\$0	0%	\$2,064,000
2007	P-1030 In-Lieu Service Area	Project	3	Groundwater Banking/Permitting	Semitropic	A, C, D, E, H, K, L		\$13,725,000	100%	\$0	0%	\$0	0%	\$13,725,000
2007	P-565 In-Lieu Service Area	Project	3	Groundwater Banking/Permitting	Semitropic	A, C, D, E, H, K, L		\$15,550,000	100%	\$0	0%	\$0	0%	\$15,550,000
2009	P-1030 Extension	Project	3	Groundwater Banking/Permitting	Semitropic	A, C, D, E, H, K, L		\$600,000	100%	\$0	0%	\$0	0%	\$600,000
2010	Conservation Improvements for Return of Banked Water <sup>1</sup>	Project	3	Groundwater Banking/Permitting	Semitropic	C, D, E, H, K, L		\$350,000	54%	\$0	0%	\$300,000	46%	\$650,000
2007 - 2011	Pond-Poso Spreading and Recovery Facility - Permitting, Env Doc, Spreading Basins and Conveyance Structures	Project	3	Conveyance/Infrastructure	Semitropic	C, D, E, G, H, K, L		\$4,423,000	68%	\$0	0%	\$2,050,000	32%	\$6,473,000
2011	Friant-Kern Canal 400 CFS Turnout No. 2	Project	3	Conveyance/Infrastructure	North Kern	C, D, E, H, K, L		\$606,000	67%	\$0	0%	\$300,000	33%	\$906,000
2011	South Intertie between North Kern and Shafter-Wasco	Project	3	Conveyance/Infrastructure	Shafter-Wasco	C, D, E, H, K, L		\$296,076	50%	\$0	0%	\$296,076	50%	\$592,152

<sup>1</sup> Activity uses estimated figures based on type and similarities to previous activities.

<sup>2</sup> Information for activity not yet obtained from applicant.

\* Measurable Objectives from Plan applied to historical projects and programs retroactively.

**Poso Creek IRWM Project and Program Report List**

Category (for historical reference):

- 1. Planning and IRWM Compliance
- 2. Community, Industrial, and Environmental-Specific
- 3. Regional Projects and Programs

Year(s)	Activity Title	Activity Type	Category	Purpose	Applicant	Measurable Objective(s)*	IRWM-Based Support	Applicant(s) Share	Applicant %	State Grant Share	State Grant %	Federal Grant Share	Federal Grant %	Total Cost(s)
2011	Turnipseed GW Banking Enhancement along White River	Project	3	Groundwater Banking/Permitting	Delano-Earlimart	C, D, E, H, K, L		\$2,000,000	56%	\$0	0%	\$1,550,000	44%	\$3,550,000
2011	Calloway Canal to Lerdo Canal Intertie <sup>1</sup>	Project	3	Conveyance/Infrastructure	North Kern and Cawelo	A, C, D, E, H, K, L		\$5,978,843	55%	\$0	0%	\$4,945,552	45%	\$10,924,395

<sup>1</sup> Activity uses estimated figures based on type and similarities to previous activities.

<sup>2</sup> Information for activity not yet obtained from applicant.

\* Measurable Objectives from Plan applied to historical projects and programs retroactively.

**Poso Creek IRWM Project and Program Report List**

Category (for historical reference):

- 1. Planning and IRWM Compliance
- 2. Community, Industrial, and Enviornmental-Specific
- 3. Regional Projects and Programs

Year(s)	Activity Title	Activity Type	Category	Purpose	Applicant	Measurable Objective(s)*	IRWM-Based Support	Applicant(s) Share	Applicant %	State Grant Share	State Grant %	Federal Grant Share	Federal Grant %	Total Cost(s)
2012	North Intertie between North Kern and Shafter-Wasco	Project	3	Conveyance/Infrastructure	Shafter-Wasco	C, D, E, H, K, L		\$501,302	63%	\$0	0%	\$296,490	37%	\$797,792
2011 - 2012	Groundwater Bank Improvements in Northwestern Kern County	Program (Planning)	1	Groundwater Banking/Permitting	Semitropic	A, C, D, E, H, K, L		\$1,000,000	52%	\$0	0%	\$917,000	48%	\$1,917,000
2012 - 2014	Pilot Arsenic Treatment Plant <sup>2</sup>	Project	3	Local Groundwater Assistance	Semitropic	G, I, K, L		\$0	0%	\$0	0%	\$0	0%	\$0
2012	Bay-Delta Ag Water Use Efficiency, NRCS on-farm funding	Project	3	General Resource Stewardship	Semitropic	I, K, L		\$0	0%	\$0	0%	\$1,000,000	100%	\$1,000,000
2013	Cross Valley Canal to Calloway Canal Intertie	Project	3	Conveyance/Infrastructure	North Kern and Cawelo	A, C, D, E, H, K, L	Direct	\$4,913,700	42%	\$6,917,524	58%	\$0	0%	\$11,831,224
2012-2014	Bay-Delta Ag Water Use Efficiency	Project	3	Conveyance/Infrastructure	Semitropic	C, E, I, K, L		\$763,470	52%	\$0	0%	\$711,170	48%	\$1,474,640
2013 - 2016	SWRU - HCP <sup>2</sup>	Program (Planning)	3	General Resource Stewardship	Semitropic	I, L, M		\$0	0%	\$0	0%	\$0	0%	\$0
2015	Semitropic Extraction - Drought Funding	Project	3	Groundwater Banking/Permitting	Semitropic	E	Indirect	\$2,112,873	25%	\$6,338,618	75%	\$0	0%	\$8,451,491
2015+	Calloway Canal Lining	Project	3	Conveyance/Infrastructure	North Kern and Cawelo	A, C, D, E, G, H ,I, L		\$1,400,000	21%	\$2,000,000	29%	\$3,400,000	50%	\$6,800,000
2015	North Kern Well Capacity	Project	3	Conveyance/Infrastructure	North Kern	A, C, D, E, G, H ,I, L		\$2,000,000	100%	\$0	0%	\$0	0%	\$2,000,000
2015	Semitropic AgWC&E WaterEnergy 2015	Project	3	Groundwater Well Improvements	Semitropic	A, C, D, E, H, K, L		\$785,087	51%	\$0	0%	\$750,000	49%	\$1,535,087
2015	Semitropic WaterSMART Drought Resiliency	Project	3	Groundwater Well Improvements	Semitropic	A, C, D, E, H, K, L		\$661,695	69%	\$0	0%	\$300,000	31%	\$961,695
2015	Arsenic Treatment Plant	Project		Modify Water Conveyance Systems	Semitropic	G, K, L		\$3,300,000	100%	\$0	0%	\$0	0%	\$3,300,000
2015	CRC Pipeline	Project	3	Water Supply / Reuse	North Kern	A, B, C, D, E	Direct	\$1,261,400	55%	\$1,018,299	45%	\$0	0%	\$2,279,699
2015	LHUD Well No.3 Study	Planning	2	DAC Assistance	Lost Hills Utility District	J, K, L		\$0	0%	\$454,000	100%	\$0	0%	\$454,000
2015	Lost Hills Groundwater Well Storage Tank	Project	2	DAC Assistance	Lost Hills Utility District	C, G, J, K, L		\$1,500,000	81%	\$350,000	19%	\$0	0%	\$1,850,000
2013-2016	Modified Madera Avenue Intertie / Kimberlina GW Recharge and Banking	Project	3	Groundwater Banking/Permitting	Shafter-Wasco	C, D, E, H, K, L		\$7,900,000	61%	\$0	0%	\$5,000,000	39%	\$12,900,000
2014	Meter Testing Facility	Project	2	General Resource Stewardship	Semitropic	A, B, C, E, F, G		\$65,392	25%	\$200,000	75%	\$0	0%	\$265,392

<sup>1</sup> Activity uses estimated figures based on type and similarities to previous activities.

<sup>2</sup> Information for activity not yet obtained from applicant.

\* Measurable Objectives from Plan applied to historical projects and programs retroactively.

**Poso Creek IRWM Project and Program Report List**

Category (for historical reference):

- 1. Planning and IRWM Compliance
- 2. Community, Industrial, and Environmental-Specific
- 3. Regional Projects and Programs

Year(s)	Activity Title	Activity Type	Category	Purpose	Applicant	Measurable Objective(s)*	IRWM-Based Support	Applicant(s) Share	Applicant %	State Grant Share	State Grant %	Federal Grant Share	Federal Grant %	Total Cost(s)
2016	Remote Sensing	Project	2	General Resource Stewardship	Semitropic	A, B, C, E, F, G		\$300,000	50%	\$300,000	50%	\$0	0%	\$600,000
2016	Friant-Kern to 8-23 Canal Intertie	Project	3	Conveyance/Infrastructure	Cawelo Water District	A, C, D, E, G, H ,I, L		\$3,250,000	46%	\$3,000,000	43%	\$750,000	11%	\$7,000,000
2016/2017	Calloway Canal Lining and Water Delivery Improvements	Project	3	Conveyance/Infrastructure	North Kern	A, C, D, E, H, K, L		\$556,755	10%	\$2,856,755	50%	\$2,300,000	40%	\$5,713,510
2016	Groundwater Well Operational Data Acquisition and Lateral Canal Lining - Phase II	Project	3	Conveyance/Infrastructure	Semitropic	A, B, C, D, E, F, G, I		\$1,039,875	51%	\$1,000,000	49%	\$0	0%	\$2,039,875
2016	Groundwater Well Extraction Improvements for Return of Stored Water: Phase 2	Project	3	Conveyance/Infrastructure	Semitropic	A, B, C, D, E, F, G, I		\$416,499	58%	\$0	0%	\$300,000	42%	\$716,499
2017	Poso Creek IRWM Plan Update	Program (Planning)	1	Prop 1 Planning	North Kern	All Objectives	Direct	\$257,264	51%	\$250,000	49%	\$0	0%	\$507,264
2017	Groundwater Recharge (Diltz) Intertie Project	Project	3	Conveyance/Infrastructure	Semitropic	A, C, D, E, H, K, L		\$946,246	56%	\$0	0%	\$750,000	44%	\$1,696,246
2017	Calloway Canal Improvements: Lining Olive Dr. to Snow Rd.	Project	3	Conveyance/Infrastructure	North Kern WSD, Cawelo WD	C, D, E, F, G, H, K, L		\$706,618	21%	\$1,428,000	42%	\$1,300,000	38%	\$3,434,618
2018	Diltz Intertie Lateral Piping and WMI	Project	3	Conveyance/Infrastructure	Shafter-Wasco	A, C, D, E, H, K, L		\$670,579	50%	\$0	0%	\$670,578	50%	\$1,341,157
2018	Well Recovery and Return Capacity Improvements	Project	3	Conveyance/Infrastructure	North Kern	A, B, D, G, J, L		\$797,121	52%	\$0	0%	\$750,000	48%	\$1,547,121
2018	Cox Pumping Plant Intertie with BVWSD	Project	3	Conveyance/Infrastructure	SWSD & BVWSD	A, B, C, D, G, H, J, L		\$1,772,561	70%	\$0	0%	\$750,000	30%	\$2,522,561
2018	Recovery and Return Capacity at Kimb SGs	Project	3	Conveyance/Infrastructure	Shafter-Wasco	A, B, D, G, J, L		\$876,885	75%	\$0	0%	\$300,000	25%	\$1,176,885
2018	North Kern SCADA Software and ET Station - Small Scale Program	Project	3	Conveyance/Infrastructure	North Kern	A, B, D, G, J, L		\$93,432	55%	\$0	0%	\$75,000	45%	\$168,432
2018	Drought Contingency Plan for Poso Creek IRWMP	Project	1	Reclamation Programs	Shafter-Wasco	A, B, D, G, J, L		\$200,000	50%	\$0	0%	\$200,000	50%	\$400,000
								\$86,898,233	57%	\$34,067,220	23%	\$30,406,666	20%	\$151,372,119

1 Activity uses estimated figures based on type and similarities to previous activities.

2 Information for activity not yet obtained from applicant.

\* Measurable Objectives from Plan applied to historical projects and programs retroactively.

## Poso Creek IRWM Report Card

Page 1 of 1

Report Card Generated on: 8/13/2019

Based on Activity Type	Total Cost(s)	Percent of Costs	Number	Percent
Planning	\$454,000	0.3%	1	1.2%
Program	\$60,000	0.0%	1	1.2%
Program (Grant App)	\$334,530	0.2%	7	8.6%
Program (Planning)	\$4,648,956	3.1%	25	30.9%
Project	\$145,874,633	96.4%	47	58.0%
<b>Total</b>	<b>\$151,372,119</b>		<b>81</b>	

Based on Year	Total Cost(s)	Percent of Costs	Number	Percent
2006	\$2,778,035	1.8%	2	2.5%
2007	\$36,053,000	23.8%	6	7.4%
2008	\$300,000	0.2%	1	1.2%
2009	\$725,822	0.5%	4	4.9%
2010	\$3,944,674	2.6%	9	11.1%
2011	\$20,671,743	13.7%	10	12.3%
2012	\$3,615,674	2.4%	10	12.3%
2013	\$26,356,884	17.4%	14	17.3%
2014	\$430,147	0.3%	2	2.5%
2015	\$27,631,972	18.3%	9	11.1%
2016	\$16,069,884	10.6%	5	6.2%
2017	\$5,638,128	3.7%	3	3.7%
2018	\$7,156,156	4.7%	6	7.4%
<b>Total</b>	<b>\$151,372,119</b>		<b>81</b>	

Based on Category	Total Cost(s)	Percent of Costs	Number	Percent
1. Planning and IRWM Compliance	\$4,415,341	2.9%	21	25.9%
2. Community, Industrial, and Environ...	\$10,192,567	6.7%	16	19.8%
3. Regional Projects and Programs	\$133,464,211	88.2%	43	53.1%
<b>Total</b>	<b>\$148,072,119</b>		<b>80</b>	

Based on Purpose (as stated)	Total Cost(s)	Percent of Costs	Number	Percent
Conveyance/Infrastructure	\$71,220,107	47.0%	21	25.9%
DAC Assistance	\$8,958,656	5.9%	10	12.3%
DWR Requirement	\$320,000	0.2%	3	3.7%
General Resource Stewardship	\$1,881,029	1.2%	5	6.2%
Groundwater Banking/Permitting	\$57,450,158	38.0%	12	14.8%
Groundwater Well Improvements	\$2,496,782	1.6%	2	2.5%
IRWM Guidelines	\$255,682	0.2%	7	8.6%
Local Groundwater Assistance	\$475,000	0.3%	3	3.7%
Modify Water Conveyance Systems	\$3,300,000	2.2%	1	1.2%
Prop 1 Planning	\$507,264	0.3%	1	1.2%
Prop 50 Planning	\$744,035	0.5%	2	2.5%
Prop 84 Planning	\$418,259	0.3%	5	6.2%
Reclamation Programs	\$529,048	0.3%	6	7.4%
System Optimization Review	\$300,000	0.2%	1	1.2%
Water Conservation	\$236,400	0.2%	1	1.2%
Water Supply / Reuse	\$2,279,699	1.5%	1	1.2%
<b>Total</b>	<b>\$151,372,119</b>		<b>81</b>	

Based on Funding Support	Total Cost(s)	Percent of Costs	Number <sup>1</sup>	Percent <sup>2</sup>
Applicant Share	\$86,898,233	57.4%	71	87.7%
Direct State IRWM Grant Support (DWR)	\$9,483,299	6.3%	10	12.3%
Indirect State IRWM Grant Support (DWR)	\$6,338,618	4.2%	1	1.2%
Other State Grant Support (DWR)	\$18,245,303	12.1%	17	21.0%
Federal Grant Support (USBR)	\$30,406,666	20.1%	27	33.3%
<b>Total</b>	<b>\$151,372,119</b>		<b>81</b>	

<sup>1</sup> Split funding shares are counted individually, represents total number of activities supported.

<sup>2</sup> Percentage of total number of activities that funding source was involved with.

## Poso Creek IRWMP Report Card Summary

The (historical) Project and Program Report List (List) and Report Card on the previous pages identify and categorize accomplishments that have occurred since the formation of the IRWM Group. All items are differentiated between structural “projects” (e.g., conveyance and infrastructure enhancements) and non-structural “programs” (e.g. planning and management documents, and grant funding applications).

The List contains completed project costs and some estimates of activity that has occurred, to capture funding over time for the IRWM-related activities and the accomplishments. The List also contains activities specifically related to on-going IRWM coordination and completion of DWR’s IRWM eligibility requirements, applications for special planning studies and implementation grants, and project implemented with local, state, and federal funding. The Poso Creek RWMG maintains a regular meeting schedule and has provided local (applicant) funding towards accomplishing specific planning activity that has achieved the following accomplishments since 2007:

- Incorporated DAC, flood control, and wildlife enhancement projects into planning through regular monthly meeting activity;
- Signed (and Updated) Governance MOU and cost sharing agreement;
- Elected DAC Representative to RWMG as part of the Governance;
- Developed DAC projects with assistance from incorporated cities and Self-Help Enterprises;
- Participated in coordination meetings with neighboring IRWMs in Tulare Basin;
- IRWM Representative of Stakeholder Oversight Advisory Committee for developing the Tulare Lake Basin Disadvantaged Community Water Study;
- Obtained Region Acceptance through DWR’s Region Acceptance Process;
- Developed CEQA and NEPA documents to allow environmental approval for the seven districts within the Poso Creek Region to bank, transfer, and exchange surface supplies for the next 25-years; this institutional change is expected to recover at least 15,000 acre-foot per year of the lost supply to the Region, and
- Remained focused on *regional* improvements by completing the following water supply enhancement projects utilizing local, state, and federal funding.

The following are some of the key conclusions from the Report Card sheet:

- 1) Since 2006 the IWMP Group has invested approximately \$87 million of applicant/local funding towards completion of projects and programs identified in the Original 2007 IRWM Plan and 2014 Plan Update and implemented by entities within the IRWM Group, principally the RWMG.
- 2) Specific districts, agencies, organizations, and individuals within the IRWM Group have received around \$34 million in State grant award funding (primarily DWR awards for IRWM and other purposes) and \$30 million in Federal grant award funding (primarily USBR awards) to accomplish said projects and programs.
- 3) The IRWM Group has identified nearly \$2 million as State categorized costs, which are related to the IRWM Group activities including program compliance and planning activities (e.g., sum of IRWM Guidelines, Prop 50 Planning, Prop

84 Planning, and Prop 1 Planning). In other words, these identified costs were part of the IRWM Groups' efforts to remain an active, eligible IRWM Program Participant. Note that the State awarded grant funding received to date has been around \$15 million (\$8 million of which was specific to the IRWM Program), representing the level of local investment that has occurred to maintain eligibility for the IRWM program.

- 4) Approximately \$9 million of State and Federal funding has gone towards nine projects and programs categorized as DAC Assistance (i.e., projects and programs with an emphasis on meeting the needs of economically-disadvantaged communities in the Region). DAC-related projects have accounted for about 12 percent of the total activities performed by the IRWM Group.
- 5) The largest funded purpose is for Groundwater Banking activities followed by investment in Conveyance/Infrastructure that serves as mechanisms to deliver or return water from groundwater banking facilities. A total of 26 percent of projects and programs completed by the IRWM Group has been related to Conveyance/Infrastructure (47 percent of costs), while 38 percent has been towards Groundwater Banking and Permitting-specific activities (15 percent of costs).

The regional approach taken by the IRWM Group has led to the successful completion of over \$151 million in planning, project (structural) and program (non-structural) implementation activities to enhance water resources management and thereby mitigate the actual and anticipated reductions to surface water supplies delivered to the region. These efforts have helped to increase water use effectiveness in the region through greater absorption and groundwater recharge and have helped to alleviate some of the water resources issues that are otherwise unresolvable and unmanageable under an individualized district planning focus. The IRWM Group will continue to explore and develop new projects and programs, with the intent on maintaining their success, by actively applying for local, State, and Federal grant opportunities when made available.



## **APPENDIX A2**

### **Plan Project and Program List**

# **Poso Creek IRWM Project and Program Report List**

## *Active Projects and Programs (Based on IRWM Group Submissions)*

The tables on the following pages include the 86 projects and programs which have been submitted by the districts, agencies, organizations, and individuals that participate in the IRWM Group. Each project and program was reviewed by the RWMG and various Work Groups as to how they achieve the Regional Goals and Measurable Objectives set forth in the IRWM Plan (2014 Plan Update, Sections 4.4 and 4.5, respectively). Applicable Measurable Objectives and Applicant(s) are identified, and each project and program is labeled with a “Map No.” corresponding to the locations in and around the Region as shown in Figure 5.1 of the Plan.

The projects and programs are also classified by a “status”, meaning the readiness for implementation and/or inclusion in grant funding applications. These designations are not part of a formal submission or review process, but are simply used by the IRWM Group as a means of tracking approved projects and programs. The following are the three statuses used:

1. “Near Term” (N), meaning a project or program has already been subjected to planning and preliminary design phases. These activities are effectively ready for implementation and will likely be included in grant applications, assuming they met funding opportunity guidelines.

2. “Long Term” (L), meaning a project or program that is only in the conceptual phase, potentially with some minor planning or design documentation. Although these activities may be streamlined to meet grant funding opportunities (i.e., pushed towards implementation readiness for a particular grant application), in general, more planning and design work will need to be performed by the Applicant and IRWM Group. As such, these activities will likely be “ready” in more than one year from the release of this Plan.

3. “Continuous/On-Going” (C), meaning a project or program which has begun but is not subjected to a near-term end (completion) date. The implementation of these activities continues over a longer period of time, with support from the IRWM Group.

The projects and programs listed in the Plan vary in terms of their generalized Purpose(s) towards the water supply and management concerns of the IRWM Group. Note that many of these projects and programs were submitted prior to or following adoption of the latest Plan. As such, the RWMG is making a concerted effort to refile and organize PDCF's for each of these activities which formally defines the purposes of each project/program, as well as an estimation of regional impacts and benefits. A PDCF for each project and program will be made available to the IRWM Group as they are compiled.

# Poso Creek IRWM Project and Program Report List

Page 1 of 8

Active Projects and Programs (Based on IRWM Group Submissions)

List Printed on: 8/13/2019

Map No. <sup>1</sup>	Status <sup>2</sup>	Year(s) <sup>3</sup>	Activity Title	Activity Type	Purpose	Applicant	Measurable Objective(s)*	Estimated Total Cost(s)
1	L	2009	North Kern and Semitropic System Interconnection	Project	Conveyance Improvements	Semitropic WSD	C, E, K, L	
2	C	2012	On-Farm Mobile Lab, Water Efficiency Services	Project	Water Conservation	North West Kern RCD	C, E, K, L, P	\$ 236,400
3	C/N	2012	NRCS On-Farm Programs for Water Quality and Supply Conservation	Program	Water Conservation	Poso Creek IRWM Group	C, E, G, K, L, P	
4	C	2013	Demand Reduction/Land Retirement	Program	Water Conservation	Semitropic WSD	I, K, L, P	
5	N	2014	Enhance Groundwater Monitoring and/or Modeling	Program	Non-Structural Enhancement to Regional Water Management	Poso Creek IRWM Group	F, G, K, L, M, N	
6	N	2014	Stormwater Improvement in McFarland	Project	Assist Economically-Disadvantaged Communities (Enhance Flood Control)	City of McFarland	H, J, K, L	
7	N	2014	Semitropic Groundwater Model Update	Program	Assess Groundwater Uses in Region	Semitropic WSD	B, F, K, L, M, N	\$ 300,000
8	N/L	2014	Calloway Canal Improvements: 8-1 Pumping Plant Connection to Friant-Kern Canal	Project	Modify Water Conveyance Systems	North Kern WSD	C, E, G, H, K, L	
9	N	2014	Regional Groundwater Assessment	Program	Assess Groundwater Uses in Region	Poso Creek IRWM Group, Kern Groundwater Semitropic WSD	B, F, K, L, M, N	
10	N	2015	Tulare Lake Floodwater Storage and Recovery Project	Project	Temporary Water Storage	City of Delano	A, C, D, E, G, H, I, L	\$ 252,970,991
11	N	2015	Delano Recycled-water Wetland Enhancement Project (DRWEP)	Project	Water Supply / Reuse		A, B, C, D, E	\$ 2,493,000
12	L	2015	Kern-Tulare Reuse of Oil Field Produced Water	Project	Water Supply / Reuse	Kern-Tulare Water District	B, C, D, F	

1 See Figure 5.1 for locations around region, labeled according to 'Map No.'

2 Status based on activity readiness for implementation, see description page for letters.

3 Anticipated year(s) of implementation or planning/preliminary design.

## Poso Creek IRWM Project and Program Report List

Page 2 of 8

Active Projects and Programs (Based on IRWM Group Submissions)

List Printed on: 8/13/2019

Map No. <sup>1</sup>	Status <sup>2</sup>	Year(s) <sup>3</sup>	Activity Title	Activity Type	Purpose	Applicant	Measurable Objective(s)*	Estimated Total Cost(s)
13	N	2015	New Well No. 3	Project	Water Supply / Reuse	Lost Hills Utility District City of McFarland	D, F, J, K, L	\$ 1,378,250
14	N	2015	Browning Road Reservoir - 1.0 million gallon Welded Steel Reservoir, Booster Pump Station, and System Intertie	Project	Conveyance Improvements		B, F, K	\$ 2,037,500

1 See Figure 5.1 for locations around region, labeled according to 'Map No.'

2 Status based on activity readiness for implementation, see description page for letters.

3 Anticipated year(s) of implementation or planning/preliminary design.

# Poso Creek IRWM Project and Program Report List

Page 3 of 8

Active Projects and Programs (Based on IRWM Group Submissions)

List Printed on: 8/13/2019

Map No. <sup>1</sup>	Status <sup>2</sup>	Year(s) <sup>3</sup>	Activity Title	Activity Type	Purpose	Applicant	Measurable Objective(s)*	Estimated Total Cost(s)
15	N	2016	Schuster Spreading Grounds	Project	Recharge & Recovery Facility	Semitropic WSD	C, D, E, H, K, L, O	\$ 875,000
16	N	2016	Shafter-Wasco Irrigation	Project	Recharge & Recovery Facility	Shafter-Wasco	C, D, E, H, K, L, O	\$ 5,840,179
17	L	2016	District Recharge Project In District Banking Projects	Project	Recharge & Recovery Facility	Irrigation District Southern San Joaquin Municipal	C, D, E, H, K, L, O	
18	L	2016	Out-of District Banking Projects	Project	Recharge & Recovery Facility	Utility District Southern San Joaquin Municipal	C, D, E, H, K, L, O	
19	C/N	2006-2014+	Oilfield Produced Water Supplies	Project	Alternative Water Supply to Reduce Dependence on Traditional Supplies	North Kern WSD	A, C, E, G, K, L	
20	N	2010+	Water Meter Installation in Wasco	Project	DAC Assistance	City of Wasco	J, K, L, P	
21	N	2012-2020	Stored Water Recovery Unit	Project	Expand In-Lieu Service Areas	Semitropic WSD	A, C, D, E, F, G, K, L	\$ 32,000,000
22	N	2013-2016	GW-Banking (North of DEID with Pixley ID)	Project	Expand Direct Recharge Facilities	Delano-Earlimart ID	C, D, E, F, G, H, K, L, O	\$ 37,000,000
23	N	2013-2016	Modified Shafter- Wasco/Semitropic Intertie on Madera Ave.	Project	Modify Water Conveyance Systems	Semitropic WSD, Shafter-Wasco ID	C, D, E, F, G, H, K, L	\$ 11,000,000
24	L	2014+	Connect Friant-Kern Canal Turnout to Cawelo's North System	Project	Expand In-Lieu Service Areas	Cawelo WD	C, D, E, K, L	
25	L	2014+	Cecil Avenue Pipeline	Project	Modify Water Conveyance Systems	Kern-Tulare WD	C, D, E, K, L	\$ 8,500,000
26	L	2014+	Capacity Expansion G-W Banking Conveyance Improvements to North Kern WSD Recharge and Recovery	Project	Expand Recharge & Recovery Facilities	North Kern WSD	C, D, E, F, G, H, K, L, O	
27	L	2014+	Phase II: Pond Poso Spreading and Recovery Facility	Project	Expand Direct Recharge Facilities	Semitropic WSD	C, D, E, F, G, H, K, L, O	

1 See Figure 5.1 for locations around region, labeled according to 'Map No.'

2 Status based on activity readiness for implementation, see description page for letters.

3 Anticipated year(s) of implementation or planning/preliminary design.

# Poso Creek IRWM Project and Program Report List

Page 4 of 8

Active Projects and Programs (Based on IRWM Group Submissions)

List Printed on: 8/13/2019

Map No. <sup>1</sup>	Status <sup>2</sup>	Year(s) <sup>3</sup>	Activity Title	Activity Type	Purpose	Applicant	Measurable Objective(s)*	Estimated Total Cost(s)
28	L	2014+	Pond-Poso Entrance Ponds	Project	Expand Direct Recharge Facilities	Semitropic WSD	C, D, E, F, G, H, K, L, O	
29	L	2014+	Calloway Canal Improvements: Calloway Canal to Friant Kern Canal Calloway Canal	Project	Modify Water Conveyance Systems	Delano-Earlimart ID	C, E, G, H, K, L	
30	L	2014+	Improvements: Siphon at CVC to Calloway Intertie Multi-District Conveyance Facility (CA Aqueduct to Friant-Kern Canal)	Project	Modify Water Conveyance Systems	North Kern WSD	C, E, G, H, K, L	\$ 2,000,000
31	L	2014+	Reverse Flow in the Friant-Kern Canal	Project	Modify Water Conveyance Systems	Semitropic WSD	A, C, D, E, F, G, H, K, L	\$ 70,000,000
32	L	2014+	Kern Canal	Project	Modify Water Conveyance Systems	Kern-Tulare WD	C, E, K, L	
33	L	2014+	Shafter-Wasco/Semitropic Intertie on Kimberlina Rd. G-W Banking for Parties	Project	Modify Water Conveyance Systems	Semitropic WSD, Shafter-Wasco ID	C, D, E, F, G, H, K, L	\$ 20,000,000
34	L	2014+	Outside Poso Creek IRWMP Region	Program	Non-Structural Enhancement to Regional Water Management	Semitropic WSD	A, C, D, E, F, G, H, K, L, N	
35	N	2014+	Reverse Flow in the CA Aqueduct	Program	Non-Structural Enhancement to Regional Water Management	Semitropic WSD	C, E, K, L	
36	N	2014+	Optimizing Region's Pumping Lifts	Program	Non-Structural Enhancement to Regional Water Management	Poso Creek IRWM Group	C, E, F, K, L, P	
37	L	2014+	Wildlife Improvement Projects in IRWMP Region (coordination with TRWP)	Project	Enhance Environmental Resources	Poso Creek IRWM Group	I, K, L	
38	L	2014+	Environmental Water Management in Support of Wildlife Settlements Outside The Poso Creek Flood	Project	Enhance Environmental Resources	Poso Creek IRWM Group	I, K, L	
39	L	2014+	Control and Water Conservation Reservoir	Project	Enhance Flood Control	Semitropic WSD, North Kern WSD, Cawelo WD. County	H, I, K, L	
40	L	2014+	Flood Management and Habitat Restoration	Project	Enhance Flood Control	North West Kern RCD	H, I, K, L, Q, R	
			Improvement along Poso					

1 See Figure 5.1 for locations around region, labeled according to 'Map No.'

2 Status based on activity readiness for implementation, see description page for letters.

3 Anticipated year(s) of implementation or planning/preliminary design.

# Poso Creek IRWM Project and Program Report List

Page 5 of 8

Active Projects and Programs (Based on IRWM Group Submissions)

List Printed on: 8/13/2019

Map No. <sup>1</sup>	Status <sup>2</sup>	Year(s) <sup>3</sup>	Activity Title	Activity Type	Purpose	Applicant	Measurable Objective(s)*	Estimated Total Cost(s)
41	L	2014+	Flood Management and Habitat Restoration	Project	Enhance Flood Control	City of McFarland	H, I, K, L, Q, R	
42	L	2014+	Improvements in McFarland Enhance Water Supply, Address Drinking Water Treatment Needs, and Lost Hills Repair and Upgrade Wastewater Treatment Plant	Project	Assist Economically-Disadvantaged Communities	Various	C, G, J, K, L	
43	N	2014+	Delano Wastewater Treatment Plant Upgrade	Project	Assist Economically-Disadvantaged Communities (Wastewater Treatment)	City of Lost Hills	C, G, J, K, L	
44	N	2014+	Delano Wastewater Treatment Plant Upgrade and Effluent Reuse	Project	Assist Economically-Disadvantaged Communities (Wastewater Treatment)	City of Delano	C, G, J, K, L	
45	N	2014+	Buttonwillow Wastewater Treatment Plant Upgrade	Project	Assist Economically-Disadvantaged Communities (Wastewater Treatment)	Community of Buttonwillow	C, G, J, K, L	\$ 4,100,000
46	N	2014+	Richgrove Waterwater Treatment Plant Upgrade	Project	Assist Economically-Disadvantaged Communities (Wastewater Treatment)	Community of Richgrove	C, G, J, K, L	
47	N/L	2014+	Richgrove CSD Water Well and Storage Tank	Project	Assist Economically-Disadvantaged Communities	Community of Richgrove	C, G, J, K, L	\$ 9,000,000
48	C/L	2014+	South Shafter Wastewater Treatment Plant Upgrade	Project	Assist Economically-Disadvantaged Communities (Wastewater Treatment)	Community of South Shafter	C, G, J, K, L	\$ 12,700,000
49	C/L	2014+	Lateral Connections, South Shafter Sewer Phase II	Project	Assist Economically-Disadvantaged Communities (Wastewater Treatment)	Community of South Shafter	C, G, J, K, L	\$ 3,397,320
50	L	2014+	Wasco Drinking Water Storage Tank	Project	Assist Economically-Disadvantaged Communities (Water Supply)	City of Wasco	C, G, J, K, L	

1 See Figure 5.1 for locations around region, labeled according to 'Map No.'

2 Status based on activity readiness for implementation, see description page for letters.

3 Anticipated year(s) of implementation or planning/preliminary design.

# Poso Creek IRWM Project and Program Report List

Page 6 of 8

Active Projects and Programs (Based on IRWM Group Submissions)

List Printed on: 8/13/2019

Map No. <sup>1</sup>	Status <sup>2</sup>	Year(s) <sup>3</sup>	Activity Title	Activity Type	Purpose	Applicant	Measurable Objective(s)*	Estimated Total Cost(s)
			Shafter-Wasco Irrigation			Shafter-Wasco		
51	N	2016+	District Recharge Project	Project	Recharge & Recovery Facility		C, D, E, H, K, L, O	\$ 5,840,179
			(Bell Recharge Site)			Irrigation District		
52	L	2017-2018	SSJMUD and Semitropic	Project	Modify Water Conveyance Systems	Joaquin Municipal Utility District	A, B, C, D, G, J, L	\$ 11,000,000
			WSD Schuster Intertie			Southern San		
53	L	2017-2018	SSJMUD and CWD Intertie	Project	Modify Water Conveyance Systems	Joaquin Municipal Utility District	A, B, C, D, F, G, J	\$ 100,000 - \$ 20,000,000
			Pipeline			Southern San		
54	L	2017-2018	SSJMUD and North Kern	Project	Modify Water Conveyance Systems	Joaquin Municipal Utility District	A, B, C, D, G, J, L	\$ 2,000,000
			WSD 9-28 Intertie Pipeline			Southern San		
55	L	2017-2018	Southeast Delano Spreading Grounds	Project	Expand Direct Recharge Facilities	Joaquin Municipal Utility District	A, B, C, D, F, G, I, J, L, O	\$ 425,000 - \$ 8,000,000
			City of Delano Spreading Grounds			Southern San		
56	L	2017-2018	Pond Road Spreading	Project	Expand Direct Recharge Facilities	Joaquin Municipal Utility District	A, B, C, D, F, G, I, J, L, O	\$ 425,000 - \$ 900,000
			Grounds			Southern San		
57	L	2017-2018	InDistrict Spreading	Project	Expand Direct Recharge Facilities	Joaquin Municipal Utility District	A, B, C, D, F, G, I, J, L, O	\$ 650,000 - \$ 6,000,000
			Grounds			Southern San		
58	N/L	2018-2019	Conversion of Dairy to Recharge Facility	Project	Expand Direct Recharge Facilities	Joaquin Municipal Utility District	A, B, C, D, F, G, I, J, L, O	\$ 44,000,000
			Improved Water Level			Southern San		
59	L	2018-2019	Measurement of District Recharge Facility	Project	Improve Monitoring of Recharge Facilities	Joaquin Municipal Utility District	A, B, C, D, F, G, I, J, L, O	\$ 5,600,000
			SCADA Automation and			Shafter-Wasco		
60	N	2018-2019	Evapotranspiration Measurement Improvements	Project	Improve Monitoring of Wells and Install ET Stations to reduce Groundwater Pumping	Irrigation District North Kern WSD	B, C, D, E, F, J, K, L, O	\$ 184,541
61	N	2018-2019					B, D E, F, J, L, M	\$ 168,432

1 See Figure 5.1 for locations around region, labeled according to 'Map No.'

2 Status based on activity readiness for implementation, see description page for letters.

3 Anticipated year(s) of implementation or planning/preliminary design.



# Poso Creek IRWM Project and Program Report List

Page 7 of 8

Active Projects and Programs (Based on IRWM Group Submissions)

List Printed on: 8/13/2019

Map No. <sup>1</sup>	Status <sup>2</sup>	Year(s) <sup>3</sup>	Activity Title	Activity Type	Purpose	Applicant	Measurable Objective(s)*	Estimated Total Cost(s)
62	L	2018-2019	Pond-Poso Spreading Grounds, Phase 2 Stored Water Recovery Unit,	Project	Expand Direct Recharge Facilities	Semitropic WSD	A, B, C, D, F, G, H, J, L, O	
63	L	2018-2019	Element of the Semitropic Groundwater Bank Installation of 123-TCP	Project	Groundwater banking	Semitropic WSD	A, B, C, D, F, G, H, J, L	\$ 197,000,000.00
64	N	2019+	Treatment Facilities Upgrade Water Meter	Project	Assist Economically-Disadvantaged Communities (Water Supply)	City of Wasco	G, J, K	
65	L	2019+	Infrastructure to Advanced Meter Infrastructure	Project	Assist Economically-Disadvantaged Communities (Water Supply)	City of Wasco	J, K, L, P	
66	L	2019+	Browning Road Well- 1,2,3-TCP Treatment	Project	Water Quality Improvements	City of McFarland	G, J, K	\$ 1,550,000.00
67	L	2019+	Municipal Water Supply Well Project	Project	Water Quality Improvements	City of McFarland	G, J, K, P	\$ 2,437,500.00
68	L	2019+	Reclaim Tank and Pump Station	Project	DAC Assistance	Lost Hills Utility District	G, J, K	\$ 35,000.00
69	L	2019+	Backwash Tank Repair	Project	DAC Assistance	Lost Hills Utility District	G, J, K	\$ 80,000.00
70	L	2019+	Feed Pump VFDs	Project	DAC Assistance	Lost Hills Utility District	G, J, K	\$ 40,000.00
71	L	2019+	SCADA Programming	Project	DAC Assistance	Lost Hills Utility District	B, G, J, L	\$ 15,000.00
72	L	2019+	Transfer Water PS Upgrades	Project	DAC Assistance	Lost Hills Utility District	G, J, K	\$ 120,000.00
73	N	2019+	Leonard Ave Pipeline	Project	Conveyance Improvements	Shafter-Wasco Irrigation District	C, D, E, F, G, H, K, L	\$ 1,724,852.00
74	L	2019+	Merced Avenue Intertie Calloway Canal	Project	Conveyance Improvements	Shafter-Wasco Irrigation District North Kern WSD	C, D, E, F, G, H, K, L	
75	N	2019+	Improvements: Lining Snow Rd. to 7th Standard Rd.	Project	Modify Water Conveyance Systems		C, E, G, H, K, L	\$ 3,133,029.00

1 See Figure 5.1 for locations around region, labeled according to 'Map No.'

2 Status based on activity readiness for implementation, see description page for letters.

3 Anticipated year(s) of implementation or planning/preliminary design.

# Poso Creek IRWM Project and Program Report List

Page 8 of 8

Active Projects and Programs (Based on IRWM Group Submissions)

List Printed on: 8/13/2019

Map No. <sup>1</sup>	Status <sup>2</sup>	Year(s) <sup>3</sup>	Activity Title	Activity Type	Purpose	Applicant	Measurable Objective(s)*	Estimated Total Cost(s)
76	N	2019+	Water Delivery Improvements	Project	Modify Water Conveyance Systems	North Kern WSD	A, C, D, E, F, H, K, L	
77	L	2019+	Calloway Canal Lining	Project	Conveyance Improvements	North Kern WSD	A, C, D, E, H, K, L	
78	L	2019+	Poso Creek Weir	Project	Conveyance Improvements	North Kern WSD	A, C, E, H, K, L	
79	L	2019+	Spreading Pond Facility	Project	Recharge & Recovery Facility	North Kern WSD	C, D, E, H, K, L, O	
80	L	2019+	Sub Surface Spreading Infrastructure	Project	Recharge & Recovery Facility	North Kern WSD	C, D, E, H, K, L, O	
81	L	2019+	Replacement of Wells	Project	Water Supply / Reuse	North Kern WSD	F, G, K, L, M, N	
82	N	2019+	Leonard Distribution System	Project	Modify Water Conveyance Systems	Semitropic WSD	C, D, E, F, G, H, K, L	\$ 6,657,936.00
83	L	2019+	Poso Creek Flood MAR	Project	Floodwater Management	Semitropic WSD	A, C, D, E, G, H, K, O	
84	C/L	2019+	Sierra Vista Water Consolidation	Project	DAC Assistance	Community of Sierra Vista	G, J, K	\$ 6,000,000.00
85	L	2019+	City of Delano Sphere of Influence Water Consolidation Study	Project	DAC Assistance	Southern San Joaquin Municipal Utility District	B, G, J, K	\$ 100,000.00
86	N	2019-2020	320-Acre Spreading Facility	Project	Groundwater Banking/Permitting	Delano-Earlimart ID	C, D, E, H, K, L	\$ 12,175,000.00
87	L	2020-2021	320-Acre Spreading Facility	Project	Groundwater Banking/Permitting	Delano-Earlimart ID	C, D, E, H, K, L	\$ 12,175,000.00
88	L	2020-2021	GW Banking Facility Pipeline Improvement Project	Project	Groundwater Banking/Permitting	Delano-Earlimart ID	C, D, E, H, K, L	\$ 2,500,000.00

1 See Figure 5.1 for locations around region, labeled according to 'Map No.'

2 Status based on activity readiness for implementation, see description page for letters.

3 Anticipated year(s) of implementation or planning/preliminary design.

Following are brief descriptions of each of the RWMG Participants involved in the Poso Creek IRWM Group planning and implementation efforts. In particular, this is to describe the water management history and current practices that influence the assets, issues, and needs identified in the Plan. Refer to the ‘IRWM Participating Districts & Agencies’ tables at the beginning of the Plan for a list of these participants, and Figure 1.2 for their locations.

### **Regional Water Management Group (RWMG) Participants**

*Semitropic Water Storage District (SWSD); IRWM Lead Agency;  
District Engineer serves as Secretary/Treasurer of the RWMG*

Address: 1101 Central Avenue  
Wasco, CA 93280  
Phone: (661) 758-5113  
Website: <http://www.semitropic.com/>



The Semitropic Water Storage District (SWSD, Semitropic) is a 221,000-acre Water Storage District located along the western portion of the Poso Creek Region, formed by local farmers in 1958 for the purpose of obtaining surface water supplies to supplement the pumping of groundwater for agricultural (irrigation) demand. During the late 1960s and early 1970s, Semitropic formulated, adopted, and implemented a project to import SWP water. The importation of SWP water commenced in the early 1970s and continues today under a contract with the KCWA for 155,000 acre-feet per year; however, the amount diverted in any given year is a function of hydrology and regulatory constraints on moving water south of the Sacramento-San Joaquin River Delta. The diversion of SWP water is through metered turnouts located along the California Aqueduct (extending along western border of District). The District maintains two primary conveyance routes; one to deliver irrigation water to the northern portion of the District, and one to deliver water to the southern portion of the District.

In the 1990s, the District developed a major groundwater banking program. Under this program, Semitropic regulates and recharges wet-year surface water supplies into the underlying groundwater basin for subsequent recovery during times of water supply deficiencies. Semitropic has long-term contracts with several banking partners, both in/near the Poso Creek Region and around the state. At the end of 2011, Semitropic held more than 900,000 acre-feet in groundwater storage on behalf of its banking partners. The groundwater banking program and water supplies are further discussed in Semitropic’s 2013 Agricultural Water Management Plan, which was adopted and submitted to the DWR. The topography in the District consists mostly of relatively flat lands which contain a mixture of annual crops (47 percent, including cotton, alfalfa, and grain) and permanent crops (53 percent, primarily nut trees). Semitropic has remained a member of the RWMG since its formation in 2006, taking on the role of IRWM Lead Agency when it comes to managing RWMG and IRWM Group affairs and maintaining compliance with State and Federal planning requirements. Owing primarily to its groundwater banking program, the District not only plays an important role in regional water management,

but in the management of water supplies for agencies ranging from the Bay area to San Diego. Accordingly, Semitropic brings an important mix of assets, issues, and needs to the IRWM Group's planning and implementation efforts.

*Shafter-Wasco Irrigation District (SWID); District General Manager serves as Chairman of RWMG*

Address: 16294 Central Valley Hwy.  
Wasco, CA 93280

Phone: (661) 758-5153

Website: <http://www.swid.org/>



The Shafter-Wasco Irrigation District (SWID, Shafter-Wasco) encompasses almost 39,000 acres, and is located in the south-central portion of the Poso Creek Region. Similar to its neighbors, the District was formed by local farmers in 1937 for the purpose of obtaining surface water supplies to supplement the pumping of groundwater for crop irrigation. Shafter-Wasco imports CVP-Friant water under a contract with the USBR (originally executed in 1955) for a maximum of 89,600 acre-feet per year (50,000 acre-feet of Class 1 water, and 39,600 acre-feet of Class 2 water). Diversions from the Friant-Kern Canal are by gravity and are made at two locations; one which serves the north half of the District, and one that serves the south half of the District. From time to time, additional supplies have been available from USBR during wet years and have typically been of relatively short duration (historically referred to as "Section 215" water). It is worth noting that Shafter-Wasco is in a strategic position with regard to facilitating transfers and exchanges with neighboring districts and agencies. Accordingly, the District has routinely worked with neighboring districts to maximize the use of surface water supplies available to the Region. The District's operations, including transfer and exchange activities, are further discussed in Shafter-Wasco's 2013 Water Conservation Plan, which was adopted by the District and submitted to the USBR. The topography in the District is relatively flat, with a gentle east-to-west slope. District lands include a large percentage of low-volume irrigated and highly managed permanent crops, primarily consisting of nut trees and grapes; however, the District's area is home to two of the Region's cities; the City of Shafter and the City of Wasco. Shafter-Wasco has remained a member of the RWMG since its formation in 2006, bringing an important mix of assets, issues, and needs to the IRWM Group's planning and implementation efforts.

*North Kern Water Storage District (NKWSD); District Engineer serves as Vice-Chairman of RWMG*

Address: P.O. Box 81435  
Bakersfield, CA 93380

Phone: (661) 746-3364

Website: <http://www.northkernwsd.com/>



The North Kern Water Storage District (NKWSD, North Kern) is a 60,000-acre Water Storage District, with a separately managed improvement district (Rosedale Ranch Improvement District) which encompasses another 7,400 acres. Located in the south-central portion of the Poso Creek Region, the District was formed in 1935, with adoption and implementation of its original project occurring in the early 1950s. The purpose of the District was to obtain surface water supplies to supplement the pumping of groundwater to meet irrigation water requirements. North Kern purchased the use of certain Kern River water rights that yield a highly variable supply from year to year. Accordingly, North Kern constructed 1,500 acres of dedicated spreading grounds to assist in regulating this supply. With the subsequent purchase of conservation space in the nearby USACE-operated Isabella Reservoir, North Kern increased its ability to regulate its Kern River water supplies. In addition to seasonal regulation, Isabella Reservoir provides North Kern with a contract right to year-to-year carryover storage which ranges from 34,000 to 48,000 acre-feet. In 1976, North Kern contracted with the City of Bakersfield for the relatively “firm” annual diversion and delivery of 20,000 acre-feet. The District’s topography evidences a gentle east-to-west slope. About 85 percent of the District’s cropped lands have been developed to low-volume irrigated permanent crops --- primarily nut trees and grapes. North Kern has remained a member of the RWMG since its formation in 2006 bringing an important mix of assets to the IRWM Group’s planning and implementation efforts, which include Kern River water rights; conservation storage space in Isabella Reservoir; significant main conveyance facilities; access to the Friant-Kern Canal; and very effective water spreading facilities.

### *Cawelo Water District (CWD)*

Address: 17207 Industrial Farm Rd.  
Bakersfield, CA 93308  
Phone: (661) 393-6070



The Cawelo Water District (CWD, Cawelo) consists of 44,700 acres in total area, with approximately 35,900 irrigated acres, of which 33,000 acres presently served with surface supplies delivered by the District. Cawelo is located in the southeastern portion of the Poso Creek Region, formed by local farmers in 1965 for the purpose of obtaining surface water supplies to supplement the pumping of groundwater for irrigation. Cawelo imports SWP water under a 1972 contract with the KCWA for 38,200 acre-feet per year, which is diverted from the California Aqueduct and conveyed in the Cross Valley Canal (CVC) as far as Bakersfield, thence pumped into North Kern’s Beardsley-Lerdo canal system, and finally lifted one more time into Cawelo. Another (historically) major source of surface water supply is Kern River water, which has been diverted under a 1976 contract with the City of Bakersfield for an average annual supply of around 27,000 acre-feet. The contract with the City expired in 2011, and Cawelo has been in discussions to reach a new agreement to continue the diversion of Kern River water. The CWD also receives 20,000 to 35,000 acre-feet per year of reclaimed oilfield-produced water under contracts with operators of nearby oilfields, all in conformance with the water quality and

waste discharge requirements of the Central Valley Regional Water Quality Control Board. These supplies are further discussed in Cawelo's 2014 Agricultural Water Management Plan, which was adopted by the District and has been submitted to the DWR. The topography in the District is characterized by flat to rolling land with an east-to-west slope, which has resulted in a large percentage of low-volume irrigated permanent crops, such as citrus, nut trees, and grapes. In fact, permanent crops account for around 82 percent of the total cropped acreage in CWD's service area. Cawelo has remained a member of the RWMG since its formation in 2006, bringing an important mix of assets, issues, and needs to the IRWM Group's planning and implementation efforts.

### *Delano-Earlimart Irrigation District (DEID)*

Address: 14181 Avenue 24  
Delano, CA 93215  
Phone: (661) 725-2526  
Website: <http://www.deid.org/>



The Delano-Earlimart Irrigation District (DEID, Delano-Earlimart) is a 56,500-acre Irrigation District located in the north-central portion of the Poso Creek Region, which was formed by local farmers in 1938 for the purpose of obtaining surface water supplies to supplement the pumping of groundwater to meet irrigation water requirements. Delano-Earlimart imports CVP-Friant water under a 1951 contract with the USBR for a maximum contract amount of 183,300 acre-feet per year (108,800 acre-feet of Class 1 water and 74,500 acre-feet of Class 2 water) through both gravity and pumped diversions along the Friant-Kern Canal, which extends north-south through the east half of the District. District operations are further discussed in Delano-Earlimart's 2013 Water Conservation Plan, which was adopted by the District and submitted to the USBR. The District's topography is relatively flat, with a mild slope towards the west. The District has been fully developed to irrigated agriculture for decades, about 80 percent of which is presently planted to low-volume irrigated permanent crops, primarily nut trees and grapes. Delano-Earlimart has remained a member of the RWMG since its formation in 2006, bringing an important mix of assets, issues, and needs to the IRWM Group's planning and implementation efforts.

### *Kern-Tulare Water District (KTWD)*

Address: 5001 California Ave. #202  
Bakersfield, CA 93309  
Phone: (661) 393-6070



The Kern-Tulare Water District (KTWD, Kern-Tulare) is an approximately 19,000-acre Water District located in the northeast portion of the Poso Creek Region, which was formed by local farmers in 1974 for the purpose of obtaining surface water supplies to supplement the pumping of groundwater to meet irrigation demands. In 2009, Kern-Tulare joined service areas

with the Rag Gulch Water District in order to better manage their collective water supplies and more effectively enter into contracts for imported surface water supplies. The combined districts retained the Kern-Tulare name, and subsequent references herein are to the combined service areas and assets. Kern-Tulare imports CVP-Delta water under a contract with the USBR for a maximum of 53,300 acre-feet per year, which is delivered by exchange through pumped diversions along the Friant-Kern Canal, which is located to the west of the District. From time to time, additional supplies have been available from the Friant Division, typically during wet years and of relatively short duration. Another (historically) major source of surface water supply is Kern River water which has been diverted under a 1976 contract with the City of Bakersfield for an average annual supply of 23,000 acre-feet. The contract with the City expired in 2012, and Kern-Tulare has been in discussions to reach a new agreement to continue the diversion of Kern River water. These supplies are further discussed in Kern-Tulare's 2013 Water Conservation Plan which was adopted by the District and submitted to the USBR. Located near the foothills of the nearby Greenhorn Mountains to the east, the District's topography consists of rolling lands sloping in a westerly direction, which has resulted in a large percentage of low-volume irrigated permanent crops, consisting primarily of citrus, nut trees, and grapes. Kern-Tulare has remained a member of the RWMG since its formation in 2006, bringing an important mix of assets, issues, and needs to the IRWM Group's planning and implementation efforts.

*North West Kern Resource Conservation District (NWKRC D)*

Address: 5000 California Ave. #100  
Bakersfield, CA 93309  
Phone: (661) 336-0967



The North West Kern Resource Conservation District (NWKRC D, North West Kern) had its beginnings in the 1960s, with the formation of local Soil Conservation Districts. The RCD is organized for the protection and conservation of soil and water resources in an area of almost 600,000 acres, which includes the Poso Creek Region. Unlike other districts in the Region, North West Kern does not have any direct responsibility for management of the Region's water supplies; rather, they provide guidance to growers regarding the on-farm management of their water supplies. In this regard, North West Kern also operates a Mobile Irrigation Lab (Mobile Lab) service for irrigation system evaluation, to assess distribution uniformity of applied irrigation water and the water-use efficiency of irrigation systems around the Region. North West Kern has remained a member of the RWMG since its formation in 2006, occupying the role of assisting landowners around the Region in their on-farm planning and implementation efforts.

*Disadvantaged Community (DAC) Representative*

Phone: (661) 758-5113

As mentioned in Section 2.2 of the Plan, the RWMG includes a DAC Representative as

part of the RWMG’s DAC Work Group (Poso Creek Region Disadvantaged Communities Group) to represent the interests and needs of DACs in the Poso Creek Region. The DAC Representative (individual) is selected via a nomination process by the IRWM Group members. Upon nomination, the DACs within the Region (reference Table 3.4) each votes for a nominee, with the successful nominee serving a two-year term with no limit on the number of terms that an individual can serve. The DAC Representative works directly with the DACs in the Region, Self-Help, and the CWC through regular meetings and open communications which are relayed to the IRWM Group throughout the planning and implementation efforts.

*Southern San Joaquin Municipal Utility District (SSJMUD)*

Address: 11281 Garzoli Ave,  
Delano, CA 93215  
Phone: (661) 725-0610  
Website: <https://www.ssjmud.org/>



The Southern San Joaquin Municipal Utility District (SSJMUD), located in the north-central portion of the Poso Creek Region, was formed in 1935 pursuant to the Municipal Utility District Act Division 6 of the Public Utility Code of the State of California, with the aim of purchasing and distributing water from the Central Valley Project (CVP). The District currently supplies agricultural water to 51,000 acres of the 67,000 acres of suburban and agricultural land comprising the District under a contract with the United States Department of Interior, Bureau of Reclamation to operate and maintain the water distribution system. SSJMUD’s purpose is to obtain and provide a supply of water for lands located within the boundaries of the District. The District lies entirely in Kern County and includes the cities of Delano and McFarland, although the District does not serve these agencies. The cities rely on the local groundwater supply, which is naturally recharged. The District provides a small amount of recharge to the groundwater reservoir supply through on-farm, in-lieu recharge efforts and recharge efforts through District reservoirs, a portion of which would benefit the urbanized areas. At the April 5, 2016 Poso Creek IRWMP RWMG meeting, the RWMG voted to accept SSMUD as a new RWMG member. The second amendment to the MOU, completed in 2016, documents the addition of SSJMUD to the Poso Creek IRWMP RWMG as a voting and cost sharing member. SSJMUD is now a member of the RWMG, bringing an important mix of assets, issues, and needs to the IRWM Group’s planning and implementation efforts.



## **APPENDIX C**

**Memorandum of Understanding (MOU), adopted May 2010, for the Regional Water Management Group (RWMG) including the MOU First Amendment (2014) and MOU Second Amendment (2016)**

## POSO CREEK INTEGRATED REGIONAL WATER MANAGEMENT PLAN REGION

### MEMORANDUM OF UNDERSTANDING

This Memorandum of Understanding, hereafter referred to as "MOU" is made and entered into by and between the districts that adopted the Poso Creek Integrated Regional Water Management Plan (Original Districts): CAWELo WATER DISTRICT, DELANO-EARLIMART IRRIGATION DISTRICT, KERN-TULARE WATER DISTRICT, NORTH KERN WATER STORAGE DISTRICT, SEMITROPIC WATER STORAGE DISTRICT, SHAFTER-WASCO IRRIGATION DISTRICT, NORTH WEST KERN RESOURCE CONSERVATION DISTRICT; and the POSO CREEK REGION DISADVANTAGED COMMUNITIES (DACs) Group. Said Districts and DAC Group shall be, for collective purposes, hereafter referred to as the "Parties." The term "Parties" shall include any parties that are added to the agreement pursuant to the provisions of this MOU.

### RECITALS

This MOU is made with reference to the following facts:

1. An initial meeting was held on April 20, 2005, to solicit input from the participating agencies regarding the preparation of an Integrated Regional Water Management Plan (IRWMP). Semitropic Water Storage District (Semitropic) submitted an application to the California Department of Water Resources and received funding for preparation of the Plan that started January 1, 2006. Semitropic acted as the Lead Agency in the development of the Poso Creek Integrated Regional Management Plan (Plan) and was responsible for all administrative reporting associated with the planning process, organized the monthly meetings, and facilitated data exchanges among participants of the Plan. The Plan was completed in July of 2007 and adopted by the Poso Creek Regional Management Group (RMG). As part of the Plan implementation, the Parties continue to meet monthly to coordinate implementation of the Plan's water management strategies and objectives. The RMG has functioned under this shared interest to develop, adopt, and implement the Plan and with Semitropic serving as the Lead Agency since inception. The purpose of executing this MOU is to formally identify the Parties' commitment to participating in various regional planning efforts as a RMG of the Poso Creek IRWMP Region.
2. The RMG that formulated and adopted the Plan is comprised of water districts that supply water to agricultural land and one resource conservation district that provides water conservation field services support to the districts. The Parties overlie that portion of the groundwater basin in the Tulare Lake Basin Hydrologic region, which is located in the northerly portion of Kern County and southerly portion of Tulare County. For the purpose of evaluating water supplies, demands, and operations, Southern San Joaquin Municipal Utilities District (SSJMUD) was included in the regional analysis.
3. For decades, the Parties have operated portions of the common groundwater basin conjunctively with the available surface supplies, as described in the Plan. Therefore, it was logical for the RMG to form and focus on the potential for increasing conjunctive use of limited surface water and groundwater supplies through regional cooperation and planning. The Region is located at the confluence of the California Aqueduct, Friant-Kern Canal, and the Kern River. The Region's assets --- state, federal, and local water supplies, proximity to major conveyance facilities of statewide importance, significant dewatered groundwater storage capacity, and significant absorptive capability that can be reached with surface water --- make it an ideal location to regulate surface supplies conjunctively with groundwater to the benefit of the

agriculture-based economy and disadvantaged communities within this Region and within the State. In addition to their geographical, hydrological, and institutional attributes, the RMG's operational knowledge proved essential when formulating the Plan. Moreover, the Plan provides this Region with the opportunity to improve the local and state-wide water supply reliability, provide drought protection, to assist economically disadvantaged communities, to assist in the management of water-related aspects of the Sacramento River Delta, and to facilitate satisfaction of the environmental water needs of the recent San Joaquin River Settlement.

4. The purpose of the Plan is to provide a framework for coordinating groundwater and surface water management activities into a cohesive set of selected management strategies and implementing the actions necessary to meet the Plan's objectives. Significant water issues facing the Region include maintaining a reliable water supply and balancing the use of surface water and groundwater supplies within the basin.

The Plan contains seven planning objectives, namely:

1. Maintain and improve water supply reliability;
2. Maintain groundwater levels at economically viable pumping lifts;
3. Protect the quality of groundwater and enhance the quality of groundwater where practical;
4. Maintain water supply costs at a level commensurate with the continued viability of the agricultural economy which has developed in the Region;
5. Enhance monitoring activities to meet groundwater level and water quality goals;
6. Maintain and/or enhance environmental resources within and outside of the Region; and
7. Enhance flood control in the Region.

Planning objectives 1 through 5 were selected by the RMG based on a consensus reached during a pre-application meeting held on April 20th, 2005. Subsequently, through further consultations, including consultations with stakeholders, these objectives were expanded to include objectives 6 and 7, and now represent the views of all Parties. Several stakeholders have participated in the monthly meetings following the Plan adoption and collaborated with the RMG to integrate their water-related projects into the Plan. Some of the participating stakeholders include Self-Help Enterprises, Tulare Basin Wildlife Partners, California Water Institute of CSU Fresno, Community Water Center, and the Sequoia River Lands Trust.

5. As part of the Plan implementation, the RMG has committed to cooperating in other planning efforts for the Tulare Lake Basin. Semitropic, acting as the lead agency, signed the Joint Powers Agreement for the Tulare Lake Hydrologic Region Water-Related Entities. The Poso RMG has coordinated their Region boundary with neighboring IRWMPs through collaboration within the JPA. The RMG developed this MOU in cooperation with the DACs within the Poso Creek Region, including the North Group of Four Cities that participated in the development of the Kern IRWMP. Since Plan adoption, the RMG has added one position as a voting member representative of the DACs within the Poso Creek Region as further defined herein.

6. This MOU is consistent with the Integrated Regional Water Management Planning Act

effective March 1, 2009 (Act).

NOW, THEREFORE, in consideration of the mutual promises, covenants and conditions hereinafter set forth, it is agreed by and among the parties as follows:

### **ARTICLE I - DEFINITIONS**

As used in this MOU, unless the context requires otherwise, the meaning of the terms used in this MOU shall be as follows:

Section 1.01 Regional Management Group (RMG) means the Original Districts and the DAC Group, recognized by this MOU, that functions as the governing body consisting of a representative from each Party.

Section 1.02 Participating Parties means the Parties representing the RMG and individual members of the Stakeholder Group.

Section 1.03 Plan means the Poso Creek Integrated Regional Water Management Plan adopted on July 26, 2007, including any modification thereof duly adopted by the RMG.

Section 1.04 Project means a project contained within the Plan.

Section 1.05 Project Agreement means an agreement among Participating Parties who undertaking a Project.

Section 1.06 Stakeholder means an entity or organization that has requested to participate in the Plan that is within or adjacent to the Region boundary as defined in the Plan and consistent with the needs and objectives stated in the Plan.

Section 1.07 DAC Representative means the representative selected from the body of disadvantage communities (DAC Group) within the Poso Creek Region Stakeholders that is recognized as a single voting entity for the purpose of governance of the RMG.

Section 1.08 Kern County IRWMP Stakeholder Representative means the representative selected from the body of Participants within the Kern IRWMP Region that is recognized as a single non-voting entity for the purpose of coordination of planning.

### **ARTICLE II - CREATION OF RMG MOU**

Section 2.01 Existence of RMG. Since March of 2006 there has been in existence a group consisting of some of the Participating Parties which later became the RMG and is now formally recognized as the governing body through this MOU.

Section 2.02 Term. This MOU shall be effective from the date of execution until terminated.

Section 2.03 Purpose. The purpose of this MOU is to provide for the governance of the Poso Creek RMG for the study, promotion and development of water management-related projects and programs and to encourage and facilitate design, financing, acquisition, construction and/or operation of same by some or all of the Participating Parties.

Section 2.04 Powers. The RMG shall have the power to study, promote and develop water management-related projects and programs and to encourage and facilitate design, financing, acquisition, construction and/or operation of same by some or all of the Participating Parties. The RMG is not authorized to finance, acquire, construct or operate Projects. It is contemplated at such time projects are ready to proceed that some or all of the Parties will enter Project Agreements for implementation of projects.

### **ARTICLE III - INTERNAL ORGANIZATION**

Section 3.01 Governing Body. The business of the Poso Creek Plan shall be conducted by the RMG. One such representative and one alternate representative shall be selected and designated in writing from time to time by the governing body of each of the Parties. A representative of each of the Parties shall sit on the RMG, which shall be selected as provided in Section 3.02 of this MOU. The role of each alternate representative shall be to assume the duties of the representative appointed by his or her member entity, in the case of absence, unavailability, or conflict by such representative and/or in the event such representative declines to serve in a capacity otherwise required for such representative. The representatives and alternates so named shall continue to serve until their respective successors are appointed.

Section 3.02 Selection of the voting representative and alternate representative to the RMG from the Disadvantaged Community (DAC) Group. The DAC Group shall be entitled to one representative and one alternate representative on the RMG of its own selection. Selection of the DAC Group representative and alternate shall be administered by the Original Districts as follows: a letter soliciting nomination of a RMG candidate to represent the DAC Group will be sent to each DAC within the Poso Creek Region, Self-Help Enterprises, Inc., and the Community Water Center. From the responses received, a list of candidates will be compiled and a ballot distributed to all DACs within the Poso Creek Region; each DAC having one vote in the election. Upon receipt of all ballots within a stated time period, the individual with the most votes shall become the DAC Group representative and the individual with the second most votes shall be the alternate. Said representative and alternate shall serve a two-year term with no limit on the number of terms that an individual can serve.

Section 3.03 Selection of the non-voting representative and alternate representative to the RMG from the Kern IRWMP Stakeholder Participants. The Kern IRWMP Participants shall be entitled to one representative and one alternate representative on the RMG of its own selection. Selection of the Kern IRWMP representative and alternate shall be administered by the Kern IRWMP Executive Committee. Upon selection by the Kern IRWMP Executive Committee, the representatives' names shall be forwarded to the then sitting RMG for acknowledgement. Said representative and alternate shall serve a two-year term with no limit on the number of terms that an individual can serve.

Section 3.04 Voting Percentage. Each RMG member shall have an equal vote on all matters affecting or undertaken by the Plan Participants. A simple majority vote of those present and voting shall be required for administrative or financial issues coming before the RMG except as otherwise provided in section 7.02 hereof. Project issues shall be decided by the Project participants in accordance with the Project Agreement.

Section 3.05 Tie Breaking. In the event of a tie vote for administrative or financial issues, the vote of the DAC Representative will be omitted for purposes of breaking the tie. In the event that this does not break the tie, the vote of the North West Kern Resources Conservation District (NWKRCDD) will be omitted for purposes of breaking the tie.

Section 3.06 Meetings.

(a) The RMG shall hold at least one regular meeting per year, and by action of the RMG entered on its minutes, may provide for the holding of regular meetings at more frequent intervals. The date upon which, and the hour and place at which, each such regular meeting shall be held shall be fixed by action of the RMG recorded on its minutes. Special meetings of the RMG may be called in accordance with the provisions of Section 54956 of the California Government Code. Whether or not required by law, all meetings of the RMG shall be called, held, noticed and conducted subject to the provisions of the Ralph M. Brown Act (Sections 54950, *et seq.* of the California Government Code). Compensation and reimbursable expenses of the RMG members

shall be set from time to time by resolution of the RMG.

(b) A quorum of the RMG shall consist of a majority of the RMG, except that less than a quorum may adjourn from time to time in accordance with law.

(c) The representatives shall select, from among their members, the following officers:

- a chairman who shall be presiding officer of all RMG meetings;
- a vice chairman who shall serve in the absence of the chairman.
- a secretary, who shall be responsible for keeping the minutes of all meetings of the RMG and all other official records of the RMG;
- a treasurer, with duties further outlined in Article IV of this MOU.

Each officer shall serve a two-year term with no limit on the number of terms that an individual can serve, provided however that the office shall be declared vacant if the person serving dies, resigns, or is removed by his or her member entity as its representative to the RMG, or if his or her member entity withdraws from this MOU pursuant to any of the provisions hereof. The representatives may also appoint such other officers and employees as it deems necessary to carry out the purposes of this MOU.

#### **ARTICLE IV - FINANCIAL PROVISIONS**

Section 4.01 Fiscal Year. The fiscal year of the RMG shall be the 12 months commencing January 1 and ending December 31. The RMG may modify the fiscal year by resolution.

Section 4.02 Depository; Treasurer. The representatives shall appoint a Treasurer for the RMG . The Treasurer shall be the depository and shall have custody of all money of the RMG, from whatever sources.

All funds of the RMG shall be strictly, and separately, accounted for, and regular reports shall be rendered of all receipts and disbursements, at least quarterly during the fiscal year. The books and records of the RMG shall be open to inspection by the Parties; The RMG may contract with an independent certified public accountant to make an annual audit of the accounts and records of the RMG.

Grant funds received by the RMG in its own name shall be disbursed and accounted for as required by law.

Section 4.03 Budget. The RMG will prepare a budget for review and adoption if it determines that it is advisable to do so.

Section 4.04 Contributions and Payments for General and Mutual Expenses.

(a) Contributions from the Parties and from the Stakeholder Group shall be made to the RMG to meet the expenses of the RMG in carrying out its purposes. Payments of public funds may be made to defray the costs incurred in carrying out such powers, and advances of funds may be made for such purposes, to be repaid as provided in this MOU, or in amendments hereto. Personnel, equipment or property of one or more of the Parties may be used in lieu of other contributions or advances, upon approval of the RMG.

(b) The allocation of the expenses shall be in accordance with the attached "Cost Share %" at Exhibit "A" hereto. Participation in expenses by the NWKRCD and the DACs are not anticipated, however, future agreements may be entered into to reallocate expenses as needed. Expenses under a Project Agreement shall be allocated in accordance with such Agreement.

## **ARTICLE V - WITHDRAWAL OF PARTIES OR STAKEHOLDER GROUP MEMBERS**

Section 5.01 Withdrawal from RMG. Any one of the Parties to this MOU who wishes to withdraw permanently from this MOU may do so upon providing ninety (90) days written notice to the RMG which notice shall contain the unconditional resolution of the governing board of said entity requesting withdrawal from the MOU. Said notice of termination shall be effective ninety (90) days from the date of its delivery to the RMG, or such lesser period as is established by the remaining Parties and no further action of the RMG shall be required in connection therewith.

Any Stakeholder who no longer wishes to associate with the RMG may do so upon providing thirty (30) days written notice to the RMG. Said notice of termination shall be effective thirty (30) days from the date of its delivery to the RMG. No further action of the RMG shall be required in connection therewith.

The withdrawing entity shall be responsible for its share of all costs, expenses, advances, and other obligations of the RMG while such withdrawing entity was a Party and the withdrawing entity or beneficiary shall also be responsible for any claims, demands, damages or liability arising from the initiation of this MOU through the date of the effectiveness of such withdrawal. The remaining Participating Parties shall have the option of discontinuing the RMG and/or acquiring the interests of the departed entity and maintaining the same proportional interest as the remaining Participating Parties, as is set forth in Article IV above.

Section 5.02 Refunds. No withdrawing entity shall be entitled to a refund of any payments made in connection with administrative and general expenses of the RMG and/or payments made in furtherance of a Project. Unexpended funds, which have not been committed for expenditure on any Project shall be remitted to the withdrawing entity in proportion to their payment, and shall be returned within thirty (30) days of the effective date of the withdrawal.

## **ARTICLE VI - RELATIONSHIP OF THE RMG AND PARTIES/STAKEHOLDERS**

Section 6.01 Not a Separate Entity. The RMG is not a separate public entity and is recognized as a group of cooperating entities mutually pursuing a common purpose as stated in the Plan and through this MOU.

Section 6.02 Additional Parties. Additional entities may join in this MOU and become Parties upon unanimous consent of the then-existing Parties. The terms and conditions of such joinder shall be set forth in an amendment to this MOU, signed by all of the then-existing parties, and shall be consistent with any contracts of the RMG then in effect.

Section 6.03 Disposition of Property Upon Termination. Upon termination of this MOU, any surplus money or other property on hand shall be returned to the then-existing Parties and any Stakeholders that have participated financially in proportion to their respective contributions.

## **ARTICLE VII - MISCELLANEOUS PROVISIONS**

Section 7.01 Dispute Resolution. All controversies among the Parties and the Stakeholders arising out of an action or decision of the RMG, or concerning the administration of this MOU shall be addressed in accordance with the provisions of this paragraph. Within ten (10) days after the action or decision has been taken, the aggrieved entity shall give written notice to the RMG and to other affected Parties or Stakeholder, stating the controversy. Within ten (10) days, thereafter, the aggrieved entity and the RMG shall meet and attempt to resolve the controversy. If following such meeting the affected Party or stakeholder is not satisfied, it may pursue whatever remedy it has.

Section 7.02 Further Amendment of this MOU. This MOU may be amended by an agreement approved by the governing boards of at least 2/3rds of the voting Parties. Approval of the RMG shall not be required for the amendment hereof provided, however any amendment of the cost share % as provided at Section 4.05 (b) shall require approval of the governing bodies of all Parties.

Section 7.03 Severability. Should any part, term or provision of this MOU be decided by the courts to be illegal or in conflict with any laws of the State of California or otherwise rendered unenforceable or ineffectual, the validity of the remaining portions, terms or provisions shall not be affected thereby.

Section 7.04 Assignment, Binding on Successors. Except as otherwise provided in this MOU, the rights and duties of the Parties to this MOU may not be assigned or delegated without the advance written consent of all of the other Parties, and any attempt to assign or delegate such rights or duties in contravention of this Section shall be null and void. Any approved assignment or delegation shall be consistent with the terms of any contracts of the RMG then in effect. This MOU shall inure to the benefit of, and be binding upon, the successors and assigns of the parties hereto.

Section 7.05 Notices. Any notice authorized or required to be given pursuant to this MOU shall be in writing and shall be deemed to have been given when mailed, postage prepaid, or delivered during working hours to the following addresses, or to such changed addresses as are communicated to the RMG and the Parties in writing:

CAWELO WATER DISTRICT  
17207 Industrial Farm Road  
Bakersfield, CA 93308-9519

DELANO-EARLIMART IRRIGATION DISTRICT  
14181 Avenue 24  
Delano, CA 93215



KERN-TULARE WATER DISTRICT  
5001 California Avenue, Suite 202  
Bakersfield, CA 93309

NORTH KERN WATER STORAGE DISTRICT  
P.O. Box 81435  
Bakersfield, CA 93380-1435

NORTH WEST KERN RESOURCE CONSERVATION DISTRICT  
5000 California Ave., Ste. 100  
Bakersfield, CA 93309

SHAFTER-WASCO IRRIGATION DISTRICT  
P.O. Box 1168  
Wasco, CA 93280

SEMITROPIC WATER STORAGE DISTRICT  
P.O. Box Z  
Wasco, CA 93280

DAC REPRESENTATIVE  
CITY OF XXX  
Street Address  
City, CA XXXXX

Agreed to this 12 day of MAY, 2010:

SEMITROPIC WATER STORAGE  
DISTRICT

By 

By Gen. Mgr.

DELANO-EARLIMART IRRIGATION  
DISTRICT

By 

By President of the Board

CAWELO WATER DISTRICT

By 

By General Manager

KERN-TULARE WATER DISTRICT

By A. C. Oalhe

By General Manager

SHAFTER-WASCO IRRIGATION  
DISTRICT

By Joseph Eze

By General Manager Secretary

NORTH KERN WATER STORAGE  
DISTRICT

By [Signature]

By General Manager

NORTH WEST KERN RESOURCE  
CONSERVATION DISTRICT

By Erin W. Harkoff

By District Manager

DAC REPRESENTATIVE

By [Signature]

City of Shafter  
By Public Works Director

**Exhibit A - Poso Creek IRWM RWMG Cost Allocation**

District	Irrigated Acres	Acres Split		Even Split		Total Share		Combined Split		
		Percent	Amount	Percent	Amount	Amount	Percent	Amount	Percent	Amount
Example for \$1,000 expense	\$1,000.00									
1st 50%, (Split Evenly)	\$500.00									
2nd 50% (Split by Acreage)	\$500.00									
Cawelo	40,257	11.54%	\$57.71	16.67%	\$83.33	\$141.04	14.10%	\$141.04		\$141.04
Delano-Earlimart	50,822	14.57%	\$72.85	16.67%	\$83.33	\$156.19	15.62%	\$156.19		\$156.19
Kern-Tulare	20,654	5.92%	\$29.61	16.67%	\$83.33	\$112.94	11.29%	\$112.94		\$112.94
North Kern	64,326	18.44%	\$92.21	16.67%	\$83.33	\$175.54	17.55%	\$175.54		\$175.54
Semitropic	142,724	40.92%	\$204.59	16.67%	\$83.33	\$287.93	28.79%	\$287.93		\$287.93
Shafter Wasco	30,016	8.61%	\$43.03	16.67%	\$83.33	\$126.36	12.64%	\$126.36		\$126.36
<b>Total</b>	<b>348,799</b>	<b>100.00%</b>	<b>\$500.00</b>	<b>100.00%</b>	<b>\$500.00</b>	<b>\$1,000.00</b>	<b>100.00%</b>	<b>\$1,000.00</b>	<b>100.00%</b>	<b>\$1,000.00</b>

**FIRST AMENDMENT TO THE POSO CREEK INTEGRATED  
REGIONAL WATER MANAGEMENT PLAN (IRWMP) REGION  
MEMORANDUM OF UNDERSTANDING**

This document represents the First Amendment to the Poso Creek Integrated Regional Water Management Plan (IRWMP) Memorandum of Understanding (MOU), adopted May 12, 2010, and is hereafter referred to as the “Amendment”. The Amendment is entered into by and between the Districts which have decided to continue participation in the Poso Creek Regional Water Management Group (RWMG), including: CAWELO WATER DISTRICT, DELANO-EARLIMART IRRIGATION DISTRICT, KERN-TULARE WATER DISTRICT, NORTH KERN WATER STORAGE DISTRICT, SEMITROPIC WATER STORAGE DISTRICT, SHAFTER-WASCO IRRIGATION DISTRICT, NORTH WEST KERN RESOURCE CONSERVATION DISTRICT, and the POSO CREEK REGION DISADVANTAGED COMMUNITIES (DACs) GROUP. Said Districts and DAC Group shall be, for collective purposes, hereafter referred to as the “RWMG”. The term “RWMG” shall include any parties that are added to the agreement pursuant to the provisions of the MOU and this Amendment.

**RECITALS**

This Amendment is made with reference to the following facts:

*Fact 01.* The Original Districts, as defined in the MOU, developed the Poso Creek Integrated Regional Water Management Plan (Plan). The Plan was completed in July of 2007 and subsequently adopted by the then termed Poso Creek Regional Management Group (RMG).

*Fact 02.* With the introduction of the *Safe Drinking Water, Water Quality and Supply, Flood Control, River and Coastal Protection Bond Act of 2006* (Proposition 84) the DWR altered the requirements of acceptable and eligible IRWMPs, thereby prompting adaptations necessary to the Plan which was originally adherent to the *Water Security, Clean Drinking Water, Coastal and Beach Protection Act of 2002* (Proposition 50). As such, the RWMG developed an updated Poso Creek Integrated Regional Water Management Plan (Updated Plan) in order to maintain compliance with DWR standards. The Updated Plan is anticipated to be completed by June 2014 and adopted by the Poso Creek Regional Water Management Group (RWMG), who have decided to remain compliant with the updated standards and continue participation in the Integrated Regional Water Management Group (IRWM Group). The purpose of executing this Amendment was to formally identify the differences between the RMG and RWMG, the goals and objectives stated in the Updated Plan, and to reiterate the

RWMG's commitment to participating in various regional planning efforts as members of the Poso Creek IRWMP Region.

*Fact 03.* The Update Plan defined the following Vision and Mission statements, that refine the RWMG's priority and solidify their regionally focused planning and implementation activities adherent to the considerations stated above, as follows:

#### Poso Creek RWMG Vision Statement

“Provide a framework for the Poso Creek IRWMP Participants, Stakeholders, and Interested Parties to identify and coordinate resource management activities through Regional Goals and Measurable Objectives.”

#### Poso Creek RWMG Mission Statement

“Facilitate plans, programs, and projects necessary to meet the Regional Goals and Measurable Objectives, and to further sustainable resource management.”

*Fact 04.* As with the Plan, the Updated Plan was developed to provide a framework for coordinating surface water, groundwater, and general resource management activities into a cohesive set of selected management strategies, projects, and programs that would be implemented to meet the Updated Plan's revised Regional Goals (Goals) and Measurable Objectives (Objectives), superseding the 2007 Plan's 'Planning Objectives' as stated in the MOU.

The Update Plan contains seven Goals, differentiated into 'Primary' and 'Secondary' Goals, representing a broadened emphasis towards more generalized resource management planning in the Region, as follows:

#### *Primary Goals*

1. Maintain and enhance water supply reliability.
2. Improve operational efficiency and flexibility.
3. Reduce water demand.
4. Protect quality of water supply.
5. Maintain economic viability of water use in Region.

#### *Secondary Goals*

6. Practice regional resource stewardship and environmental awareness.
7. Improve flood management.

The Updated Plan also defines fourteen Objectives, developed as a means of accomplishing the Goals stated above, to directly support the DWR Statewide Priorities and Resource Management Strategies (RMSs) applicable to the Region, and to identify projects and programs suitable for implementation to meet the Regional Priorities for the RWMG. The Objectives are as follows:

- A. Enhance reliability of surface water supplies delivered to Region.
- B. Identify any significant threats to groundwater resources from overdrafting.
- C. Improve regional water conveyance, direct recharge, and in-lieu service areas.
- D. Increase absorptive capacity within the Region.
- E. Promote regional conjunctive water-use.
- F. Support groundwater monitoring activities.
- G. Maintain and enhance quality of water supply.
- H. Enhance region-wide flood control measures.
- I. Promote environmental conservation and support wildlife habitat enhancement.
- J. Identify drinking water quality issues of communities, water-related needs of DACs, and consider improvements.
- K. Implement regional opportunities, projects, and programs.
- L. Implement region-wide water management actions.
- M. Maintain compliance with State and Federal planning requirements.
- N. Maintain coordination between Poso Creek RWMG and Interested Parties.

*Fact 05.* This Amendment, by association with the MOU, is consistent with the Integrated Regional Water Management Planning Act effective March 1, 2009 (Act).

NOW, THEREFORE, in consideration of the mutual promises, covenants and conditions set forth in the MOU, the following amendments are agreed by and among the RWMG as follows:

### **ARTICLE I AMENDMENTS**

The following section(s) from the MOU shall be amended under this Amendment to the following:

*Section 1.01* “Regional Water Management Group (RWMG)” means the Original Districts and the DAC Group, recognized by this MOU, which functions as the governing body consisting of a representative from each party. The RWMG term shall replace the definition and usage of the “Regional Management Group” (RMG) term in the MOU.

*Section 1.02* “RWMG Participant” means the parties representing the RWMG and individual members of the RWMG, for instance, an individual District or the DAC Group.

The RWMG Participant term shall replace the definition and usage of the

“Participating Parties” term in the MOU.

*Section 1.06* “Stakeholder” means an entity or organization that has requested to participate in regional planning and implementation efforts that is within or adjacent to the Region boundary as defined in the Plans. These parties generally include entities or organizations which may be individually impacted by the planning and implementation efforts of the RWMG, and is consistent with the Goals and Objectives stated in the Plans. The Stakeholder definition given here shall replace the definition of Stakeholder provided in the MOU.

The use of the “Stakeholder” term throughout the MOU shall be replaced by the IRWM Group Member definition given in this Amendment below.

The following section(s) shall be added under this Amendment to the MOU, as follows:

*Section 1.09* “Interested Party” means an entity, organization, or individual that has requested to participate in regional planning and implementation efforts to any and all extents, including public participation. These parties generally include all participants in the planning and implementation efforts of the RWMG, not considered under the RWMG or Stakeholders.

*Section 1.10* “Integrated Regional Water Management Group” (IRWM Group) means the arrangement of RWMG, Stakeholders, and Interested Parties who participate in the planning and implementation efforts and assist in development of the Plans. This title defines the entirety of parties involved in the Poso Creek Integrated Regional Water Management Plan.

*Section 1.11* “IRWM Group Member” is a broadened term meaning any individual entity, organization, or individual that occupies any role in the IRWM Group.

*Section 1.12* “Updated Plan” means the Poso Creek Integrated Regional Water Management Plan developed by the IRWM Group and intended for adoption by June 2014, including any modification thereof duly adopted by the RWMG.

Unless otherwise stated in this Amendment, the Updated Plan shall be considered interchangeable with the Plan as used throughout the MOU.

## **ARTICLE V AMENDMENTS**

The following section(s) from the MOU shall be amended under this Amendment to the following:

*Section 5.01* Withdrawal from RWMG: Any RWMG Participant who wishes to withdraw permanently from the MOU may do so upon providing ninety (90)

days written notice to the RWMG. The written notice shall contain the unconditional resolution of the governing board of said entity requesting withdrawal from the MOU. Said notice of termination shall be effective ninety (90) days from the date of its delivery to the RWMG, or such lesser period as is established by the RWMG and no further action of the RWMG shall be required in connection therewith. A withdrawn RWMG Participant may remain active in the IRWM Group, in a Stakeholder or Interested Party role, but will no longer receive the benefits of governance provided in the MOU.

Any Stakeholder or Interested Party who no longer wishes to associate with the IRWM Group may do so upon their desire. Although it is not required, any entities or organizations that withdraw from either of these roles should provide a written notice to the RWMG. No further action of the RWMG shall be required in connection therewith.

Any withdrawing entity shall be responsible for its share of all costs, expenses, advances, and other obligations of the RWMG while such withdrawing entity was a member of the IRWM Group, in particular a RWMG Participant, and the withdrawing entity or beneficiary shall also be responsible for any claims, demands, damages or liability arising from the initiation of this MOU through the date of the effectiveness of such withdrawal. The RWMG shall have the option of discontinuing the RWMG and/or acquiring the interests of the departed entity and maintaining the same proportional interest, as is set forth in Article IV.

## **ARTICLE VI AMENDMENTS**

The following section(s) from the MOU shall be amended under this Amendment to the following:

*Section 6.03* Additional IRWM Group Participants: Additional entities may become involved in the IRWM Group under the role of a Stakeholder or Interested Party. Stakeholders have continued and historic contributions to the planning and implementation efforts of the IRWM Group, and are recognized by the RWMG for their continual support and participation. Entities, organizations, or individuals need not be recognized by the RWMG to participate in all IRWM Group efforts as an Interested Party.



This Amendment to the MOU is agreed to this 20th day of June, 2014 by the RWMG:

CAWELO WATER DISTRICT  
17207 Industrial Farm Road  
Bakersfield, CA 93308-9519

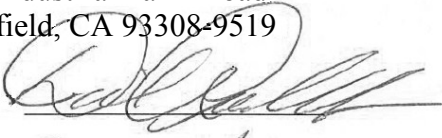
Signed 

Title General Manager

KERN-TULARE WATER DISTRICT  
5001 California Ave, Suite 202  
Bakersfield, CA 93309

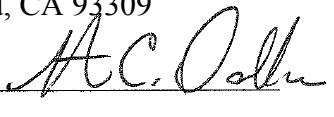
Signed 

Title General Manager

NORTH KERN WATER STORAGE DISTRICT  
P.O. Box 81435  
Bakersfield, CA 93380-1435

Signed 

Title General Manager

DELANO-EARLIMART IRRIGATION DISTRICT  
14181 Avenue 24  
Delano, CA 93215

Signed 

Title General Manager

SHAFTER-WASCO IRRIGATION DISTRICT  
P.O. Box 1168  
Wasco, CA 93280

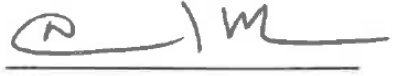
Signed 

Title General Manager

SEMITROPIC WATER STORAGE DISTRICT  
P.O. Box 8043  
Wasco, CA 93280

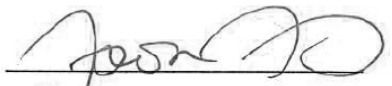
Signed 

Title General Manager

NORTH WEST KERN RESOURCE CONSERVATION DISTRICT  
5000 California Ave., Ste. 100  
Bakersfield, CA 93309

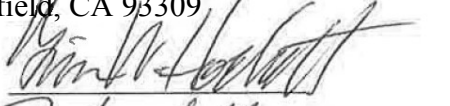
Signed 

Title District Manager

DAC GROUP REPRESENTATIVE

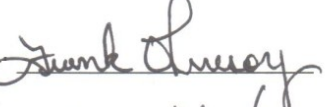
Signed 

Title DAC Representative / Suppl. Fund USD

**SECOND AMENDMENT TO THE POSO CREEK INTEGRATED  
REGIONAL WATER MANAGEMENT PLAN (IRWMP) REGION  
MEMORANDUM OF UNDERSTANDING**

This document represents the Second Amendment to the Poso Creek Integrated Regional Water Management Plan (IRWMP) Memorandum of Understanding (MOU), adopted May 12, 2010, and is hereafter referred to as the "Second Amendment". At the April 5, 2016 Poso Creek IRWMP RWMG meeting, the RWMG voted to accept Southern San Joaquin Municipal District (SSJMUD) as a new RWMG member provided SSJMUD agreed to reimburse the Poso Creek IRWMP RWMG for expenditures not covered by grant funding and provided direct benefit to SSJMUD. The amount required for SSJMUD to reimburse the Poso Creek IRWMP RWMG is identified in the April 5, 2016 meeting Minutes.

Given SSJMUD has accepted the terms to reimburse the Poso Creek IRWMP RWMG, the purpose of this Second Amendment to the Poso Creek IRWMP MOU is to recognize SSJMUD as a voting and cost sharing member of the Poso Creek IRWMP Regional Water Management Group (RWMG). This Second Amendment, completed in 2016, is to document the addition of SSJMUD to the Poso Creek IRWMP MOU by adding the necessary statements to the First Amendment to the MOU, which was completed in 2014 as part of the Poso Creek IRWMP Update.

The Second Amendment is entered into by and between the Districts which have decided to continue participation in the Poso Creek Regional Water Management Group (RWMG), including: CAWELLO WATER DISTRICT, DELANO-EARLIMART IRRIGATION DISTRICT, KERN-TULARE WATER DISTRICT, NORTH KERN WATER STORAGE DISTRICT, SEMITROPIC WATER STORAGE DISTRICT, SHAFTER-WASCO IRRIGATION DISTRICT, SOUTHERN SAN JOAQUIN MUNICIPAL UTILITY DISTRICT, NORTH WEST KERN RESOURCE CONSERVATION DISTRICT, and the POSO CREEK REGION DISADVANTAGED COMMUNITIES (DACs) GROUP. Said Districts and DAC Group shall be, for collective purposes, hereafter referred to as the "RWMG". The term "RWMG" shall include any parties that are added to the agreement pursuant to the provisions of the MOU and this Second Amendment.

**RECITALS**

This Amendment is made with reference to the following facts:

*Fact 01.* The Original Districts, as defined in the MOU, developed the Poso Creek Integrated Regional Water Management Plan (Plan). The Plan was completed in July of 2007 and subsequently adopted by the then termed Poso Creek Regional Management Group (RMG) and updated in 2014 by the clarified name, Poso Creek Regional Water Management Group (RWMG).

*Fact 02.* With the introduction of the *Safe Drinking Water, Water Quality and Supply, Flood Control, River and Coastal Protection Bond Act of 2006* (Proposition 84) the DWR altered the requirements of acceptable and eligible IRWMPs, thereby prompting adaptations necessary to the Plan which was originally adherent to the *Water Security, Clean Drinking Water, Coastal and Beach Protection Act of 2002* (Proposition 50). As such, the RWMG developed an updated Poso Creek Integrated Regional Water Management Plan (Updated Plan) in order to maintain compliance with DWR standards. The Updated Plan was completed by June 2014 and adopted by the Poso Creek Regional Water Management Group (RWMG), who has decided to remain compliant with the updated standards and continue participation in the Integrated Regional Water Management Group (IRWM Group). The purpose of executing the First Amendment was to formally identify the differences between the RMG and RWMG, the goals and objectives stated in the Updated Plan, and to reiterate the RWMG's commitment to participating in various regional planning efforts as members of the Poso Creek IRWMP Region.

*Fact 03.* The 2014 Updated Plan defined the following Vision and Mission statements, that refine the RWMG's priority and solidify their regionally focused planning and implementation activities adherent to the considerations stated above, as follows:

#### Poso Creek RWMG Vision Statement

“Provide a framework for the Poso Creek IRWMP Participants, Stakeholders, and Interested Parties to identify and coordinate resource management activities through Regional Goals and Measurable Objectives.”

#### Poso Creek RWMG Mission Statement

“Facilitate plans, programs, and projects necessary to meet the Regional Goals and Measurable Objectives, and to further sustainable resource management.”

*Fact 04.* As with the Plan, the Updated Plan was developed to provide a framework for coordinating surface water, groundwater, and general resource management activities into a cohesive set of selected management strategies, projects, and programs that would be implemented to meet the Updated Plan's revised Regional Goals (Goals) and Measurable Objectives (Objectives),

superseding the 2007 Plan's 'Planning Objectives' as stated in the MOU.

The Update Plan contains seven Goals, differentiated into 'Primary' and 'Secondary' Goals, representing a broadened emphasis towards more generalized resource management planning in the Region, as follows:

*Primary Goals*

1. Maintain and enhance water supply reliability.
2. Improve operational efficiency and flexibility.
3. Reduce water demand.
4. Protect quality of water supply.
5. Maintain economic viability of water use in Region.

*Secondary Goals*

6. Practice regional resource stewardship and environmental awareness.
7. Improve flood management.

The Updated Plan also defines fourteen Objectives, developed as a means of accomplishing the Goals stated above, to directly support the DWR Statewide Priorities and Resource Management Strategies (RMSs) applicable to the Region, and to identify projects and programs suitable for implementation to meet the Regional Priorities for the RWMG. The Objectives are as follows:

- A. Enhance reliability of surface water supplies delivered to Region.
- B. Identify any significant threats to groundwater resources from overdrafting.
- C. Improve regional water conveyance, direct recharge, and in-lieu service areas.
- D. Increase absorptive capacity within the Region.
- E. Promote regional conjunctive water-use.
- F. Support groundwater monitoring activities.
- G. Maintain and enhance quality of water supply.
- H. Enhance region-wide flood control measures.
- I. Promote environmental conservation and support wildlife habitat enhancement.
- J. Identify drinking water quality issues of communities, water-related needs of DACs, and consider improvements.
- K. Implement regional opportunities, projects, and programs.
- L. Implement region-wide water management actions.
- M. Maintain compliance with State and Federal planning requirements.
- N. Maintain coordination between Poso Creek RWMG and Interested Parties.

*Fact 05.* This Amendment, by association with the MOU, is consistent with the Integrated Regional Water Management Planning Act effective March 1, 2009

(Act).

NOW, THEREFORE, in consideration of the mutual promises, covenants and conditions set forth in the MOU, the following amendments are agreed by and among the RWMG as follows:

### **ARTICLE I AMENDMENTS**

The following section(s) from the MOU shall be amended under this second Amendment to the following:

*Section 1.01* “Regional Water Management Group (RWMG)” means the Original Districts, the addition of Southern San Joaquin Municipal Utility District, and the DAC Group, recognized by this MOU, which functions as the governing body consisting of a representative from each party. The RWMG term shall replace the definition and usage of the “Regional Management Group” (RMG) term in the MOU.

*Section 1.02* “RWMG Participant” means the parties representing the RWMG and individual members of the RWMG, for instance, an individual District or the DAC Group.

The RWMG Participant term shall replace the definition and usage of the “Participating Parties” term in the MOU.

*Section 1.06* “Stakeholder” means an entity or organization that has requested to participate in regional planning and implementation efforts that is within or adjacent to the Region boundary as defined in the Plans. These parties generally include entities or organizations which may be individually impacted by the planning and implementation efforts of the RWMG, and is consistent with the Goals and Objectives stated in the Plans. The Stakeholder definition given here shall replace the definition of Stakeholder provided in the MOU.

The use of the “Stakeholder” term throughout the MOU shall be replaced by the IRWM Group Member definition given in the first Amendment as listed below.

The following section(s) were added under the first Amendment to the MOU, as follows:

*Section 1.09* “Interested Party” means an entity, organization, or individual that has requested to participate in regional planning and implementation efforts to any and all extents, including public participation. These parties generally include all participation in the planning and implementation efforts of the RWMG, not considered under the RWMG or Stakeholders.

*Section 1.10* "Integrated Regional Water Management Group" (IRWM Group) means the arrangement of RWMG, Stakeholders, and Interested Parties who participate in the planning and implementation efforts and assist in development of the Plans. This title defines the entirety of parties involved in the Poso Creek Integrated Regional Water Management Plan.

*Section 1.11* "IRWM Group Member" is a broadened term meaning any individual entity, organization, or individual that occupies any role in the IRWM Group.

*Section 1.12* "Updated Plan" means the Poso Creek Integrated Regional Water Management Plan developed by the IRWM Group and adopted in June 2014, including any modification thereof duly adopted by the RWMG.

Unless otherwise stated in this Amendment, the Updated Plan shall be considered interchangeable with the Plan as used throughout the MOU.

#### **ARTICLE V AMENDMENTS**

The following section(s) from the MOU were amended under the First Amendment and remain effective under this Second Amendment.

The following section(s) from the MOU were amended under the First Amendment to the following:

*Section 5.01* Withdrawal from RWMG: Any RWMG Participant who wishes to withdraw permanently from the MOU may do so upon providing ninety (90) days written notice to the RWMG. The written notice shall contain the unconditional resolution of the governing board of said entity requesting withdrawal from the MOU. Said notice of termination shall be effective ninety (90) days from the date of its delivery to the RWMG, or such lesser period as is established by the RWMG and no further action of the RWMG shall be required in connection therewith. A withdrawn RWMG Participant may remain active in the IRWM Group, in a Stakeholder or Interested Party role, but will no longer receive the benefits of governance provided in the MOU.

Any Stakeholder or Interested Party who no longer wishes to associate with the IRWM Group may do so upon their desire. Although it is not required, any entities or organizations that withdraw from either of these roles should provide a written notice to the RWMG. No further action of the RWMG shall be required in connection therewith.

Any withdrawing entity shall be responsible for its share of all costs, expenses,

advances, and other obligations of the RWMG while such withdrawing entity was a member of the IRWM Group, in particular a RWMG Participant, and the withdrawing entity or beneficiary shall also be responsible for any claims, demands, damages or liability arising from the initiation of this MOU through the date of the effectiveness of such withdrawal. The RWMG shall have the option of discontinuing the RWMG and/or acquiring the interests of the departed entity and maintaining the same proportional interest, as is set forth in Article IV.

### ARTICLE VI AMENDMENTS

The following section(s) from the MOU remain effective under this Second Amendment as amended under the First Amendment to the following:

*Section 6.04* Additional IRWM Group Participants: Additional entities may become involved in the IRWM Group under the role of a Stakeholder or Interested Party. Stakeholders have continued and historic contributions to the planning and implementation efforts of the IRWM Group, and are recognized by the RWMG for their continual support and participation. Entities, organizations, or individuals need not be recognized by the RWMG to participate in all IRWM Group efforts as an Interested Party.

This Second Amendment to the MOU is agreed to this 2<sup>nd</sup> day of August, 2016 by the RWMG:

CAWELO WATER DISTRICT  
17207 Industrial Farm Road  
Bakersfield, CA 93308-9519

Signed 

Title General Manager

KERN-TULARE WATER  
DISTRICT  
5001 California Avenue, Suite 102  
Bakersfield, CA 93309

Signed 

Title General Manager

NORTH KERN WATER  
STORAGE DISTRICT  
P.O. Box 81435  
Bakersfield, CA 93380-1435

Signed 

Title General Manager

DELANO-EARLIMART  
IRRIGATION DISTRICT  
14181 Avenue 24  
Delano, CA 92315

Signed 

Title GENERAL MANAGER

SHAFTER-WASCO IRRIGATION  
DISTRICT  
P.O. Box 1168  
Wasco, CA 93280

Signed 

Title General Manager

SEMITROPIC WATER STORAGE  
DISTRICT  
P.O. Box 8043  
Wasco, CA 93280

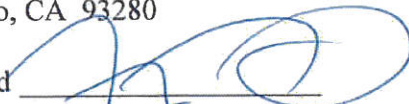
Signed 

Title General manager

DAC GROUP REPRESENTATIVE  
(Current Representative in-charge)

Signed 

Title Superintendent

NORTH WEST KERN RESOURCE  
CONSERVATION DISTRICT  
5000 California Ave., Ste. 100  
Bakersfield, CA 93309

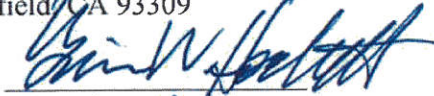
Signed 

Title District Manager

SOUTHERN SAN JOAQUIN MUNICIPAL WATER DISTRICT

11281 Garzoli Avenue

Delano, CA 93215

Signed 

Title General Manager





## **APPENDIX D**

### **Public Notices for Integrated Regional Water Management (IRWM) Plan Update**

A public notice of the proposition to update the Poso Creek IRWM Plan pursuant to §6066 of the Government Code will be performed and subsequently documented in this appendix. Following completion of the Plan update, a notice of intention to adopt the Plan will be performed and subsequently documented in this appendix pursuant to Water Code §10543.

## **APPENDIX E**

### **Resolution of Integrated Regional Water Management (IRWM) Plan Update Adoption by the Regional Water Management Group (RWMG)**

A *Resolution of Integrated Regional Water Management (IRWM) Plan Update Adoption* (Resolution) will be filed following approval of the 2019 IRWM Plan Update by the Regional Water Management Group (RWMG), on behalf of the IRWM Group. A copy of the Resolution will be contained in this appendix.

Additionally, A *Resolution of Integrated Regional Water Management (IRWM) Plan Update Adoption* (Resolution) will be filed following approval of the 2019 IRWM Plan Update by the Project Proponents. A copy of the Resolution will be contained in this appendix.



**POSO CREEK INTEGRATED REGIONAL WATER MANAGEMENT (IRWM) GROUP  
2019 IRWM PLAN UPDATE**

**PROOF OF ADOPTION BY IRWM GROUP**

The *Poso Creek Integrated Regional Water Management (IRWM) Group* is represented by the Regional Water Management Group (RWMG), which includes the Semitropic Water Storage District (acting as the IRWM Leading Agency), Cawelo Water District, Kern-Tulare Water District, North Kern Water Storage District, Shafter-Wasco Irrigation District, Southern San Joaquin Municipal Utility District, North West Kern Resource Conservation District, and a Representative for the Poso Creek Region Disadvantaged Communities (DACs) Group (DAC Representative).

A draft *2019 Poso Creek Integrated Regional Water Management Plan Update (Plan)* was prepared to compliment and expand upon the original 2007 *Poso Creek Integrated Regional Water Management Plan*, and more recently, the 2014 *Poso Creek Integrated Regional Water Management Plan Update*. The Plan was drafted in accordance with the IRWM Plan Standards set forth in the January 2016 Integrated Regional Water Management Grant Program Guidelines published by the Department of Water Resources (DWR) and the State Water Resources Control Board (SWRCB) pursuant to the California Water Code Sections 79740 –79748.

The draft Plan has undergone a thorough review by the RWMG, on behalf of the IRWM Group, and has completed a public review period. Pursuant to the Memorandum of Understanding (MOU), signed August 25, 2010, which sets forth the governance and management structure of the RWMG, the RWMG acknowledges the preparation of the Plan as compliant with DWR and SWRCB standards and requirements.

On this day, \_\_\_\_\_, 2019, the participants that form the Regional Water Management Group signed this Proof of Adoption to acknowledge the adoption of the 2019 Poso Creek Integrated Regional Water Management Plan Update by their respective agencies.

---

Jason Gianquinto  
General Manager  
Semitropic Water Storage District

---

David R. Ansolabehere  
General Manager  
Cawelo Water District

---

Steven C. Dalke  
General Manager  
Kern-Tulare Water District

---

Richard Diamond  
General Manager  
North Kern Water Storage District

---

Dana S. Munn  
General Manager  
Shafter-Wasco Irrigation District

---

Roland Gross  
General Manager  
Southern San Joaquin Municipal Utility District

---

Brian Hockett  
District Manager  
North West Kern Resource Conservation District

---

Poso Creek IRWM Chairperson

---

DAC Representative



**POSO CREEK INTEGRATED REGIONAL WATER MANAGEMENT PLAN  
2019 IRWM PLAN UPDATE**

**PROOF OF ADOPTION BY PROJECT PROPONENT**

The *Poso Creek Integrated Regional Water Management (IRWM) Group* is represented by the Regional Water Management Group (RWMG), which includes the Semitropic Water Storage District (acting as the IRWM Leading Agency), Cawelo Water District, Kern-Tulare Water District, North Kern Water Storage District, Shafter-Wasco Irrigation District, Southern San Joaquin Municipal Utility District, North West Kern Resource Conservation District, and a Representative for the Poso Creek Region Disadvantaged Communities (DACs) Group (DAC Representative). The RWMG formally adopted the 2019 IRWM Plan Update on June \_\_, 2019.

A draft *2019 Poso Creek Integrated Regional Water Management Plan Update (Plan)* was prepared to compliment and expand upon the original 2007 *Poso Creek Integrated Regional Water Management Plan* and subsequent 2014 *Poso Creek Integrated Regional Water Management Plan*. The Plan was drafted in accordance with the IRWM Plan Standards set forth in the January 2016 Integrated Regional Water Management Grant Program Guidelines published by the Department of Water Resources (DWR) and the State Water Resources Control Board (SWRCB) pursuant to the California Water Code Section 79740 –79748.

The draft Plan has undergone a thorough review by the RWMG, on behalf of the IRWM Group, has been reviewed by the Project Proponent, and has completed a public review period. The Project Proponent acknowledges the preparation of the Plan as compliant with DWR and SWRCB standards and requirements.

On this day, \_\_\_\_\_ \_\_\_\_, 2019, the Project Proponent signed this Proof of Adoption to acknowledge the adoption of the 2019 Poso Creek Integrated Regional Water Management Plan Update.



---

General Manager  
Lost Hills Utility District

---

Public Works Director  
City of Wasco

---

Superintendent  
Maple Elementary School District

---

Authorized Representative  
Community of North Shafter

---

Authorized Representative  
Community of South Shafter

---

Authorized Representative  
Community of Richgrove

---

City Engineer  
City of Shafter

---

City Engineer  
City of Delano

---

Authorized Representative  
City of Lost Hills

---

Public Works Director  
City of McFarland

## **APPENDIX F**

### **Poso Creek Regional Water Demand and Supply Analyses from the 2007 Integrated Regional Water Management Plan (IRWMP)<sup>1</sup>**

#### **APPENDIX F1**

##### **Chapter 4: Historical and Projected Water Supplies**

#### **APPENDIX F2**

##### **Chapter 5: Historical Water Use and Projected Water Demand**

#### **APPENDIX F3**

##### **Chapter 7: Water Supply Operations Studies**

---

<sup>1</sup> Appendix includes chapters copied directly from the 2007 IRWMP, as referenced throughout this Plan. Refer to the 2007 IRWMP for more information regarding figures, tables, and references for this text.. Acronyms from these chapters are included in the List of Acronyms at the beginning of this Plan.

## **APPENDIX F1**

### **Chapter 4: Historical and Projected Water Supplies**

## 4 Historical and Projected Water Supplies

---

The fundamental questions which are addressed in this section are ...

- *How much surface water has been brought into the Region in the past?*
- *What are the fluctuations in groundwater levels that have been observed in the past?*
- *How much surface water will be available in the future?*

### 4.1 Overview of Water Supply Sources

All of the water districts within the Poso Creek RMA conjunctively use both surface water and groundwater to meet water requirements. Surface water sources include both local supplies and imported supplies. The Kern River is the primary source of local supply; however, Poso Creek and other minor streams contribute to the locally-available supplies from time to time. In addition, water produced in the operation of the Kern River oilfield has contributed to the region's water supply. Sources of imported supplies include both the Central Valley Project (CVP) and the State Water Project (SWP)

CVP water from the Friant Division is conveyed to the Region through the Friant-Kern Canal, and SWP water is conveyed through the California Aqueduct, along with CVP water from the Delta Division, as shown schematically on Figure 4-1.

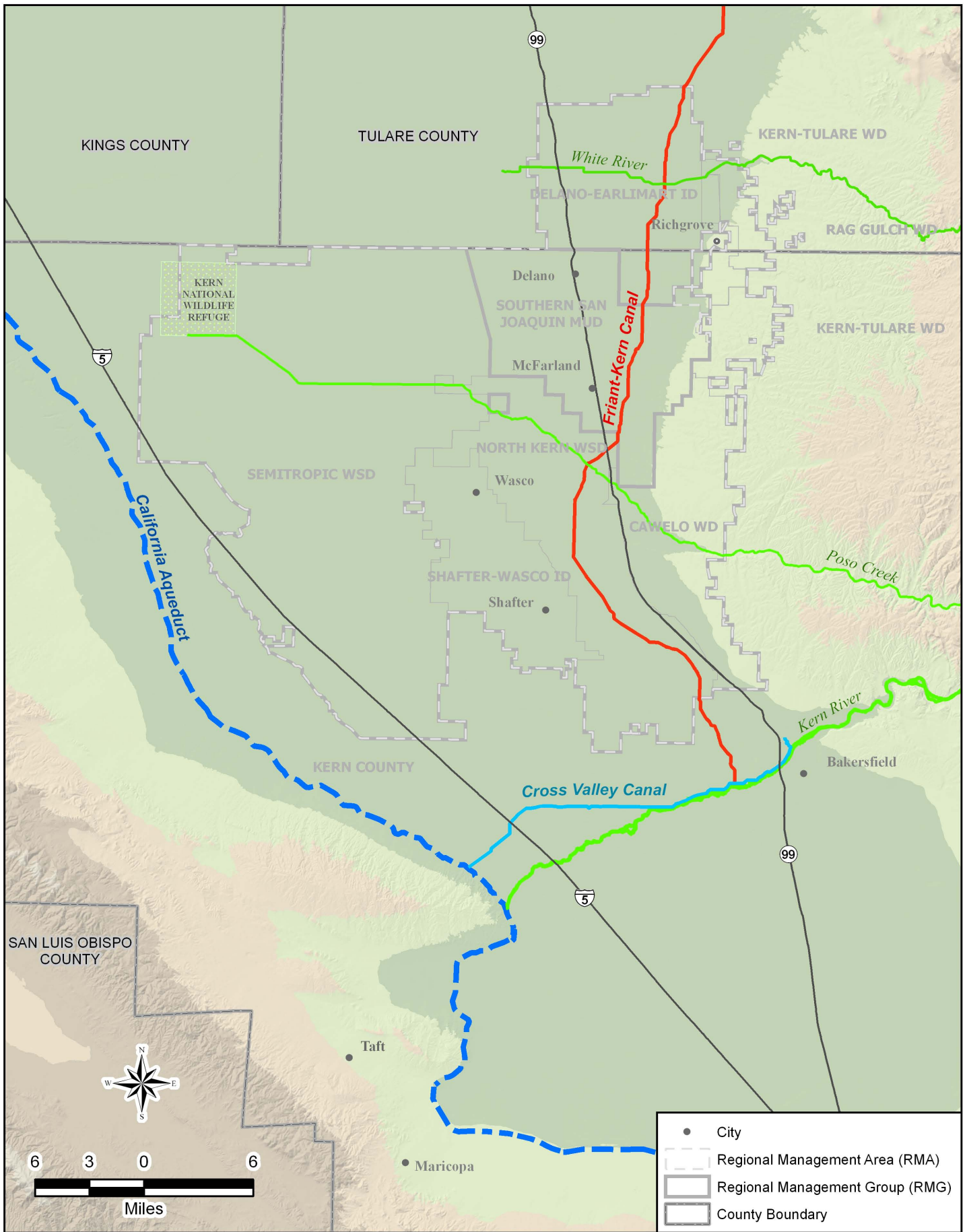

The Poso Creek Regional Management Group (RMG) members are listed, along with their respective sources of water supply, in Table 4-1. These water sources are discussed in more detail in subsequent sections of this chapter.

**Table 4-1**  
**Checklist of Water Supply Sources for the Regional Management Group**

	SWP	CVP Delta	CVP Friant	Kern River	Poso Creek or Other Local Streams	Ground-water
Cawelo	✓			✓	✓	✓
Delano-Earlimart			✓		✓	✓
Kern-Tulare		✓		✓	✓	✓
North Kern				✓	✓	✓
Rag Gulch		✓		✓	✓	✓
Semitropic	✓				✓	✓
Shafter-Wasco			✓			✓
Southern San Joaquin			✓			✓

For purposes of this investigation, historical averages are based on the 25-year period extending from 1981 through 2005, for all members except the newly added SSJMUD, unless noted otherwise. For the Poso Creek RMA, the historical average use of local and imported water supplies is illustrated in Figure 4-2.

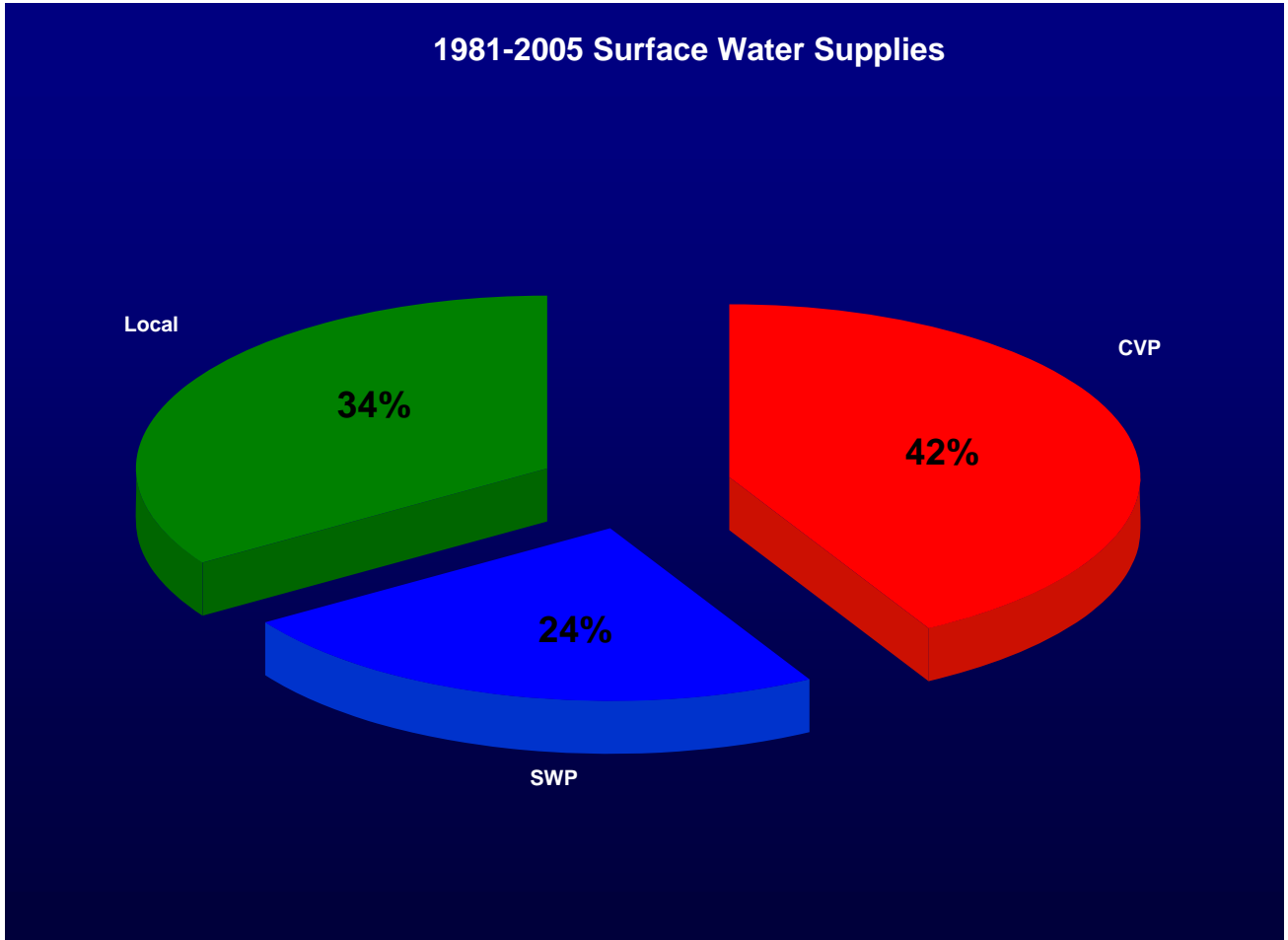



On average, local surface water supplies have amounted to about one-third of the total surface water supplies of the Region, with imported supplies making up the remaining two-thirds.

Over the years, both regulatory decisions and court decisions have impacted the availability of the Region’s imported water supplies. In recent years, environmental and water quality issues in and surrounding the Sacramento-San Joaquin River Delta (Delta) have limited the ability to export water south of the Delta, which has reduced the reliability of SWP water supplies and CVP-Delta supplies available to the Region. For similar reasons, the reliability of CVP supplies from the Friant Division has been threatened for many years and will be significantly impacted under an agreement which was recently reached in settlement of long-standing litigation. Given the Region’s heavy reliance on imported water supplies to support the irrigated agricultural economy, local measures to mitigate this loss of reliability will continue to be a high priority for the Region.

The reliability of the Kern River supplies that have been used in the Region in the past is also threatened, owing to the expiration of several long-term contracts in 2011, as well as ongoing litigation. Accordingly, all three of the principal sources of surface water supplies have experienced or will experience reduced reliability. This is the common denominator that brought the Poso Creek RMG together; in particular, the belief that by pooling their respective assets, they could implement measures and arrangements to regulate their collective water supplies at a regional level, and thereby mitigate the loss of reliability that has been experienced to date and that which is on the horizon.

## 4.2 Historical Conditions

For the purpose of characterizing historical water supply conditions, this investigation has relied on the 25-year period extending from 1981 through 2005. While this period may or may not be representative of long-term hydrology, it does contain both *wet* and *dry* cycles, which allow for observations to be made with respect to the response of the underlying groundwater system to changes in water supply. Further, the fundamental water supplies and infrastructure for the Poso Creek RMA were largely in place for the entirety of this period. For example, while deliveries of CVP water into the area commenced in the 1950s, deliveries of SWP water did not commence until the 1970s. Further, Kern River water under long-term contracts with the City of Bakersfield was not delivered into the RMA until the late 1970s.

### 4.2.1 Kern River

The Kern River is the primary source of local surface water supply to the San Joaquin Valley portion of Kern County. Since the 1870s, a portion of this supply has been conveyed to the north of the Kern River fan into the Poso Creek RMA. In particular, Kern River water has been conveyed into the area of North Kern through two main canals; the Beardsley Canal and the Calloway Canal, both of which divert directly from the channel of the Kern River. More

recently, in the late 1970s, delivery of Kern River water into the eastern portion of the Poso Creek RMA commenced. In particular, Cawelo, Kern-Tulare, and Rag Gulch began receiving Kern River water under long-term contracts with the City of Bakersfield.

Hydrology - Based on over 100 years of records, the average annual runoff of the Kern River is in excess of 700,000 acre-feet. However, runoff varies widely from year to year; the maximum annual recorded amount having been some 2.5 million acre-feet in 1983 (about 340 percent of the long-term average) and the minimum having been about 177,000 acre-feet in 1961 (about 25 percent of the long-term average). As a result, history has shown that two out of three years produce below-average runoff. This variability has made regulation of the supply essential. Regulation is accomplished through a combination of underground storage and surface storage.

Storage and Regulation of Kern River - Prior to the realization of surface regulation of Kern River (in 1954), North Kern formulated and implemented a project whereby supplies which are available in excess of irrigation requirements are percolated into underground storage through the use of over 1,500 acres of spreading ponds. Conversely, when surface supplies are short, deep wells are used to recover the previously stored water. Accordingly, for more than 50 years, North Kern has achieved a high degree of conservation and use of this widely varying source of supply through direct diversions to irrigated lands and through incidental and intentional percolation to underground storage.

Since the mid 1950s, Isabella Dam and Reservoir, constructed by the U.S. Corps of Engineers (USACE) just downstream of the confluence of the north and south forks of the river, has provided additional regulation. The reservoir, completed in 1954, has a storage capacity of almost 570,000 acre-feet and provides flood control, water conservation and recreation

The flood control operational criteria require that the water in storage be drawn down to a minimum conservation storage level of 170,000 acre-feet from November 1<sup>st</sup> through February 1<sup>st</sup> of each year. Allowable storage levels through the succeeding months of the flood season, extending to August 1<sup>st</sup>, are established on the basis of the periodically surveyed water content of the snow pack and projected runoff in each year. Through arrangements among the river interests, and partially as a result of the construction and activation of the Kern River Intertie<sup>1</sup>, stored water carryover up to 245,000 acre-feet has been permitted. Through arrangements with the stream irrigation interests, a minimum reservoir pool of 30,000 acre-feet is maintained for recreation purposes.

Only in exceptionally *wet* years is there Kern River water that cannot be regulated for either irrigation or spreading.

---

<sup>1</sup> Completed in 1978, this facility allows for the controlled diversion of Kern River water into the California Aqueduct.

Water Quality - The quality of Kern River water is excellent, generally less than 100 milligrams per liter of total dissolved solids. The water is suitable (from a mineral water quality standpoint) for both municipal and irrigation uses.

**4.2.2 Minor Streams**

Poso Creek originates to the east of the Poso Creek RMA, with its headwaters in the Greenhorn Mountains. For the last 25 years, records of stream flow at Highway 65<sup>2</sup> have been maintained. This location marks the point at which Poso Creek enters Cawelo, which is also coincident with the eastern boundary of the Poso Creek RMA. This highly erratic local stream traverses the northeastern portion of the region, generally along a southeast-to-northwest alignment. Figure 4-3 illustrates the fluctuation in annual runoff volumes which enter the region as surface flow. The average annual runoff for 1982 through 2005 was about 22,000 acre-feet; however, it is noteworthy that almost one-half of this average was the result of two very wet years, 1983 and 1998. As shown on Figure 4-4, most of the runoff has occurred in the months of January through May, with little to no flow in the remaining months, except during very wet years. Owing to its highly erratic nature, the primary use of this supply is its contribution to the underlying groundwater supply, both through natural recharge in the stream channel and North Kern’s and Cawelo’s intentional water-spreading activities.

Commencing in 1997, diversions have been governed by an agreement<sup>3</sup> between North Kern, Cawelo, and Semitropic, who collectively share the runoff of Poso Creek. Under the agreement, riparian users are first satisfied, after which the sharing between the parties is in accordance with the following schedule (based on the measured flow of Poso Creek at Highway 65):

<i>Less than 135 cfs</i>	<i>Cawelo</i>
<i>Between 135 cfs and 300 cfs</i>	<i>North Kern</i>
<i>Between 300 cfs and 685 cfs</i>	<i>Semitropic</i>
<i>Over 685 cfs</i>	<i>North Kern</i>

Located to the north of Poso Creek, and of lesser importance in terms of its contribution to recharge, is the White River. In this regard, the drainage area of the White River is less than one-half that of Poso Creek. Stream flow records for the White River over the last 25 years are not as good as those for Poso Creek; however, the average annual runoff volume is estimated to be on the order of 6,000 to 7,000 acre-feet. The White River courses from east to west across the north end of Kern-Tulare and Rag Gulch, then across the center of Delano-Earlimart.

<sup>2</sup> The drainage area of Poso Creek above State Highway 65 is about 328 square miles (USACE 1981).

<sup>3</sup> Agreement Regarding Operation and Monitoring of Poso Creek Flows, dated May 23, 1997; amended September 21, 1999.

### Annual Runoff of Poso Creek at Hwy 65

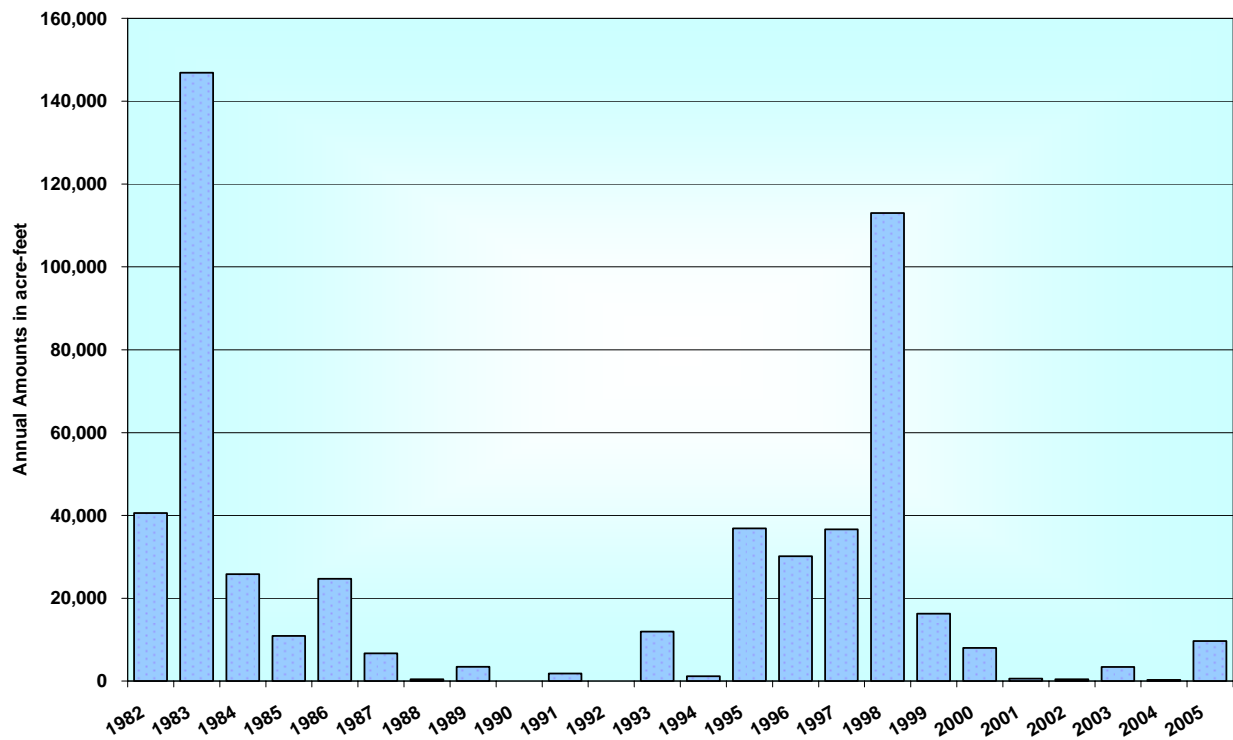

Average Monthly Distribution of Poso Creek Runoff at Hwy 65

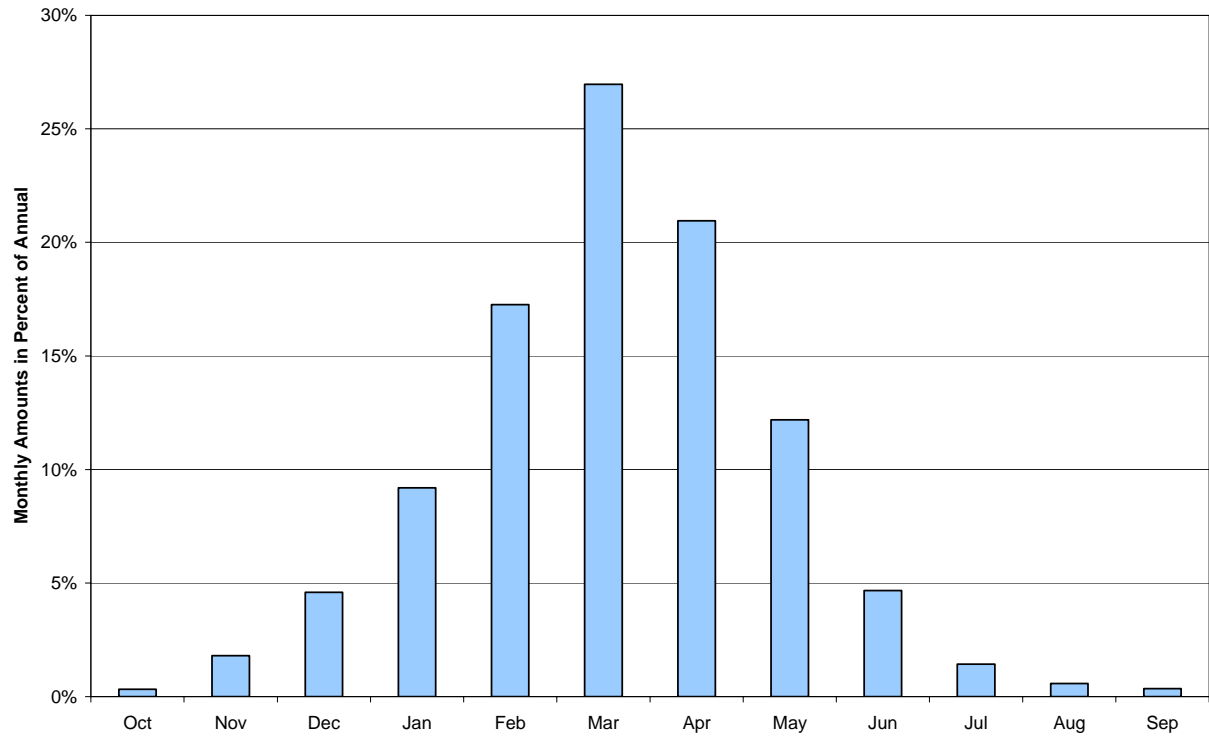

### **4.2.3 Oilfield-Produced Water**

The Kern River oilfield, located adjacent to the southeast boundary of the Poso Creek RMA, is currently one of the top three producing oilfields in Kern County. Water is produced as a by-product of the production of oil. While some of this water is reintroduced in the form of steam to facilitate the production of oil, there remains a significant amount of water for other uses. With some treatment, this remaining supply has been delivered into the Poso Creek RMA for irrigated agricultural uses. In particular, North Kern and Cawelo have been the recipients of this oilfield-produced water.

North Kern - North Kern began receiving oilfield-produced water in 1980, with annual amounts ranging from 100 acre-feet to over 10,000 acre-feet, and averaging about 5,000 acre-feet per year. Physically, this water has been discharged into, and conveyed in, North Kern's Beardsley Canal.

Cawelo - From 1980 until the mid 1990s, Cawelo depended on North Kern's conveyance facilities to receive water from this source of supply. During this period of time, the amount of oilfield-produced water available to Cawelo varied considerably from year to year, and averaged less than 2,000 acre-feet annually. In 1995, an 8-mile pipeline was constructed from the Kern River oilfield to Cawelo, which provided for direct delivery of the oilfield-produced water to Cawelo. Since that time, Cawelo has received from 18,000 to 22,000 acre-feet annually from this source.

### **Recycled Water**

Water recycling within the Region includes both M&I wastewater effluent and water used to create waterfowl habitat in the Kern National Wildlife Refuge.

Wastewater Effluent - To the extent that wastewater is collected and treated by the communities located within the Region, the treated effluent is typically used to grow crops in the Region. Over the last 15 years, the annual volume of wastewater effluent has ranged from 5,000 to 10,000 acre-feet.

Kern National Wildlife Refuge - Some of the water which is used to create waterfowl habitat in the fall and winter is released in the spring as ponds are drawn down. The released water, which can range from 500 to 2,000 acre-feet annually, is used to irrigate crops in the area.

### **4.2.4 Central Valley Project – Friant Division**

The Friant-Kern Canal is a feature of the U.S. Bureau of Reclamation's (USBR) Central Valley Project. The canal diverts water from Millerton Reservoir, created by Friant Dam on

the San Joaquin River, and extends southward a distance of 152 miles through Fresno, Tulare and Kern counties to its terminus at the Kern River near Bakersfield. While the reservoir capacity is about 520,000 acre-feet, 130,000 acre-feet of this amount is not useable as conservation space inasmuch as it lies below the intake for the Friant-Kern Canal. The capacity of the Canal at its head is 5,300 cubic-feet per second, and it gradually reduces to 2,000 cfs at its terminus. A number of water districts along the east side of the San Joaquin Valley, including three within the Poso Creek RMA, entered into long-term water supply contracts with the USBR, which provide for the delivery of three types of water; Class 1, Class 2, and “Other”. Figure 4-5 shows the Friant-Kern Canal and its proximity to water districts in the Poso Creek RMA.

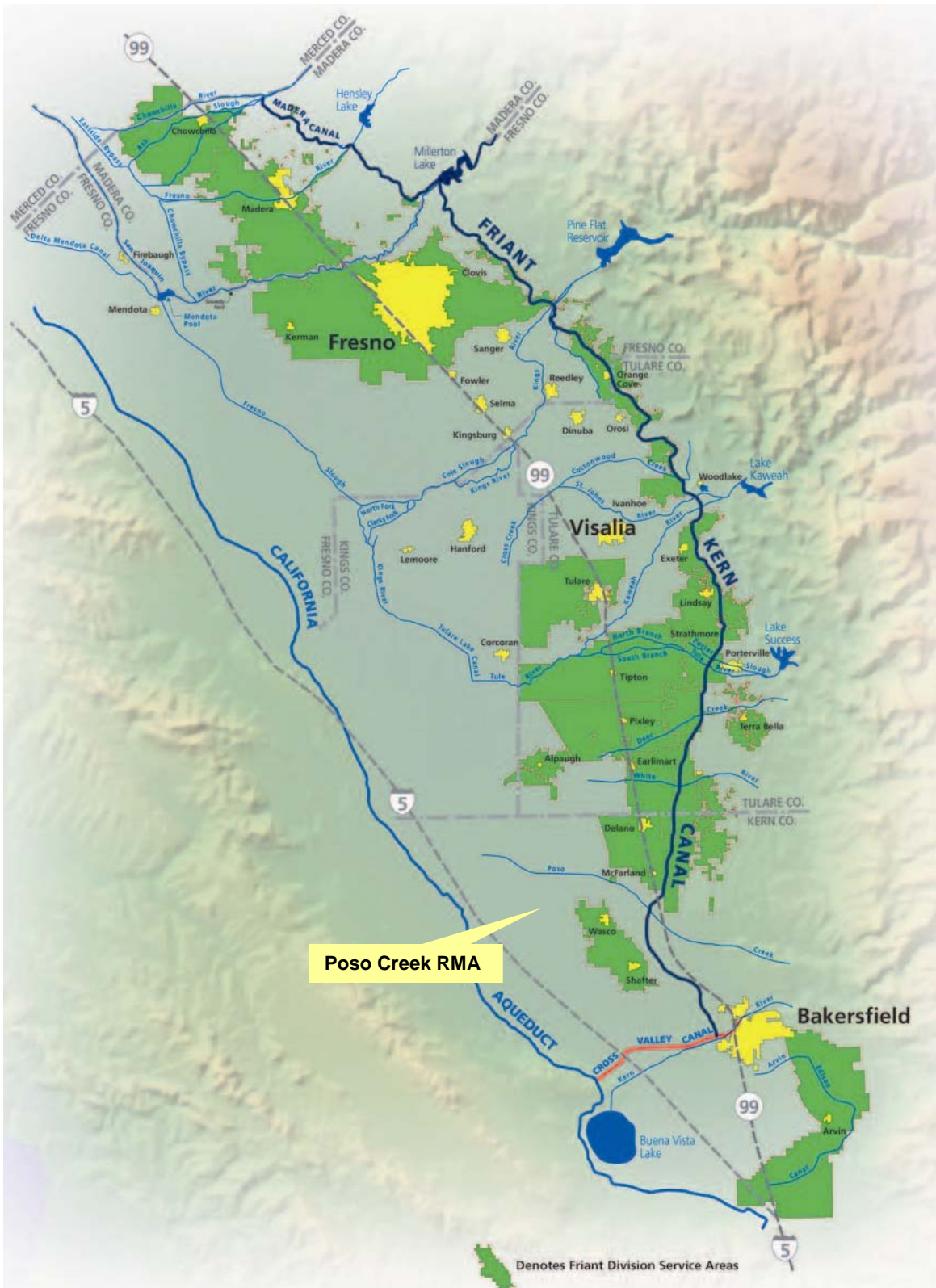

Source: Friant-Water Users Authority website - <http://www.friantwater.org/>

Poso Creek Integrated Regional Water Management Plan

Poso Creek Regional Management Group



Friant-Kern Canal and its Proximity to Water Districts in the Poso Creek RMA

June 2007

Figure 4-5



Class 1 Water - This class of water provides a relatively *firm* or regulated supply and contracts for this water total about 800,000 acre-feet per year, about one-third of which is contracted to districts within the Poso Creek RMA, as shown below, along with the year that deliveries commenced.

Delano-Earlimart	108,000 af	1950
Shafter-Wasco	50,000	1957
Southern San Joaquin	<u>97,000</u>	1951
Total:	255,000 af	

Class 2 Water - This type of water is made available after Class 1 demands have been met; accordingly, there are many years when this class of water is not available or is available in small amounts. In particular, in about one out of three years, the allocation ranged from zero to 10 percent. Contracts for Class 2 water total about 1.4 million acre-feet, with about 164,000 acre-feet contracted to districts in the Poso Creek RMA, as shown below.

Delano-Earlimart	74,500 af
Shafter-Wasco	39,600
Southern San Joaquin	<u>50,000</u>
Total:	164,100 af

Since this water is less *firm*, it cannot always be regulated to meet an irrigation demand. In these instances, Delano-Earlimart, Shafter-Wasco, and Southern San Joaquin have historically forgone delivery within their districts in favor of diversion and use by other Friant Division contractors who have a coincident demand for the supply.

Other Water - Historically, this water has commonly been referred to as *Section 215 water*, which is water that is not storable for *Project* purposes (i.e., for meeting contract obligations for Class 1 and Class 2 water). This type of water has occurred in exceptionally large water supply years or from infrequent and otherwise unmanaged flood flows of short duration. This water has also been available under temporary contracts to districts who are not long-term Friant contractors. It is noteworthy that the *acreage limitation* provisions of *Reclamation law* do not apply to this type of water.

The historical allocation priorities for this water are listed following:

- (1) Long-term contractors;
- (2) Cross Valley contractors;

- (3) Other parties within the Friant Division service area with direct delivery capabilities;
- (4) CVP contractors outside of the Friant Division service area; and
- (5) Other parties.

Water Quality - The quality of Friant-Kern water is excellent, with generally less than 100 milligrams per liter of total dissolved solids.

Poso Creek RMA - Deliveries of CVP-Friant water to districts within the Poso Creek RMA have averaged about 292,000 acre-feet per year for 1981-2005, ranging from less than 200,000 acre-feet (1990) to more than 350,000 acre-feet. The annual fluctuation in deliveries is illustrated on Figure 4-6.

#### **4.2.5 Central Valley Project – Delta Division**

In 1973, the California Department of Water Resources completed the initial facilities of the State Water Project, including the main line of the California Aqueduct. Portions of the SWP were developed to be used in conjunction with the United States Bureau of Reclamation (Reclamation), Central Valley Project (CVP). As the state and federal projects developed, a group of San Joaquin Valley water users planned the Cross Valley Canal as a means of taking delivery of CVP water supplies available in the Delta. The Cross Valley Canal was completed in 1975 and, in 1976, the water users, which included Kern-Tulare and Rag Gulch, entered into three-party contracts with DWR and Reclamation. Under these contracts, CVP water which is made available by Reclamation in the Delta is diverted from the Delta by the SWP’s Harvey O. Banks Pumping Plant; however, it is subordinate to pumping by DWR for SWP purposes. The water is then conveyed by DWR in the California Aqueduct to Tupman, where it is diverted into the Cross Valley Canal, and delivered directly to Kern-Tulare and Rag Gulch or exchanged with Arvin-Edison Water Storage District for water available in the Friant-Kern Canal.

#### **4.2.6 State Water Project**

The California Aqueduct is the principal conveyance feature of the State Water Project. In contrast to the Friant-Kern Canal, which is located on the east side of the San Joaquin Valley, the California Aqueduct conveys imported water (in this case, SWP water) into the Region along the west side of the San Joaquin Valley. The Kern County Water Agency (KCWA) was formed in the 1960s to contract with the California Department of Water Resources (DWR) for the importation of SWP water to Kern County. Individual water districts within the County then contracted with KCWA for an imported water supply, which included both Cawelo and Semitropic. These contracts provided for two types of water; relatively *firm* water (referred to as *Table A water*), and *surplus* water (referred to as *Article 21 water*).

While Semitropic has turnouts directly from the Aqueduct into its area, SWP water is conveyed to Cawelo through the Cross Valley Canal.

Historical Deliveries of CVP-Friant Water to the Poso Creek RMA

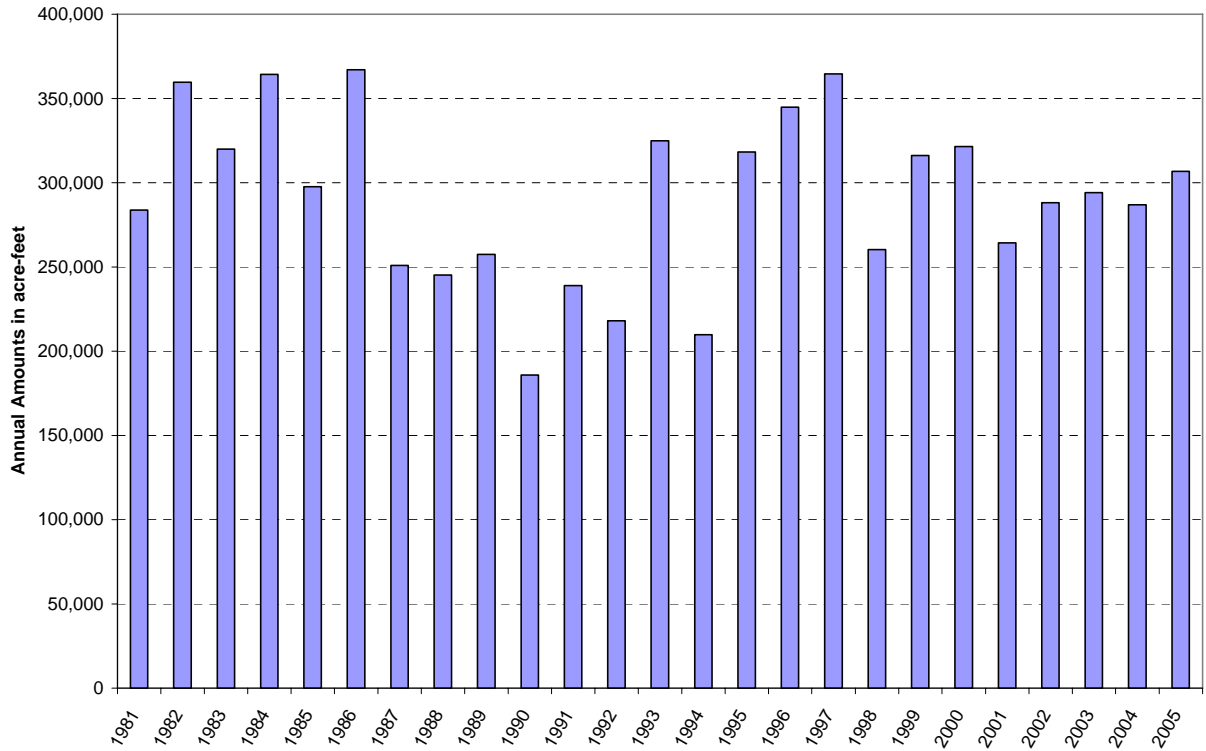

*Table A Water* - *Table A* is an exhibit to the contract between the DWR and the SWP contractors that serves as the basis for allocating available water supply among the contractors of the SWP. Table 4-2 shows the maximum annual *Table A* amounts for the entire SWP service area, the San Joaquin Valley, and for the Kern County Water Agency.

**Table 4-2**  
**Maximum Annual SWP *Table A* Amounts**  
 (Source: The SWP Delivery Reliability Report 2005)  
 (Units: acre-feet)

SWP Service Area	San Joaquin Valley	Kern County Water Agency
4,172,786	1,170,000	998,730

Collectively, Semitropic and Cawelo have contracted for almost 20 percent of the total KCWA *Table A* amount, as shown below:

Cawelo	38,200 af
Semitropic	<u>155,000</u>
Total	193,200 af

Deliveries of SWP water to Cawelo and Semitropic commenced in the 1970s; however, owing to the incomplete status of the SWP and regulatory restrictions on pumping from the Delta, the SWP is unable to deliver full (100%) *Table A* amounts in most years. Accordingly, a percent allocation is set each year which is applied to each contractor’s *Table A* amount, where the percent allocation is a function of many factors, including hydrologic conditions, reservoir storage, and projected runoff (based on snow surveys). Table 4-3 shows the historical deliveries of *Table A* water to KCWA, from 1981 through 2005.

**Table 4-3**  
**Historical Deliveries of Table A Water to**  
**the Kern County Water Agency**  
 (Source: The SWP Delivery Reliability Report 2002 and 2005  
 DWR, 2003 and 2006)  
 (Units: acre-feet)

Year	Amount
1981	1,340,581
1982	895,193
1983	595,112
1984	1,099,391
1985	1,083,749
1986	927,545
1987	1,021,953
1988	1,009,520
1989	1,146,062
1990	712,448
1991	33,122
1992	483,220
1993	1,167,930
1994	657,159
1995	1,151,529
1996	1,185,063
1997	1,102,807
1998	858,590
1999	1,178,150
2000	1,151,159
2001	484,991
2002	729,058
2003	900,387
2004	771,685
2005	898,857

While the reliability of this source of supply is far less than anticipated when contracts were executed, a contract amendment was made as a result of the *Monterey Agreement* in 1994, which put agricultural and urban contractors on equal footing respecting the allocation of water supply shortages. Prior to the amendment, agricultural contractors were burdened with a larger share of any shortages.

*Article 21 Water* - Unlike *Table A water*, *Article 21 water* cannot be scheduled; rather, it must be taken at the time it is declared to be available. It is analogous to *Section 215 water* for the CVP-Friant contractors (which was discussed previously in Section 4.2.4). The following conditions govern the availability of *Article 21 water*:

- (1) It is available only when it does not interfere with Table A allocations and SWP operations;
- (2) It is available only when excess water is available in the Delta;
- (3) It is available only when conveyance capacity is not being used for SWP purposes or scheduled SWP deliveries; and
- (4) It cannot be stored within the SWP system. In other words, the contractors must be able to use the Article 21 water directly or store it in their own system.

As a result of these conditions, *Article 21 water* is made available during the *wet* months of the year, typically December through March. Table 4-4 summarizes the historical deliveries of *Article 21 water* to the Kern County Water Agency from 1981-2005.

**Table 4-4**  
**Historical Deliveries of Article 21 Water to**  
**Kern County Water Agency**  
 (Source: The SWP Delivery Reliability Report 2002 and 2005  
 DWR, 2003 and 2006)  
 (Units: acre-feet)

<b>Year</b>	<b>Amount</b>
1981	649,181
1982	149,336
1983	605
1984	238,791
1985	191,957
1986	20,002
1987	0
1988	0
1989	0
1990	0
1991	0
1992	0
1993	0
1994	58,474
1995	59,671
1996	15,653
1997	10,264
1998	0
1999	58,241
2000	78,908
2001	23,233
2002	21,951
2003	27,891
2004	86,513
2005	471,847



If there is more demand for *Article 21 water* than the amount declared to be available, it is apportioned to those contractors requesting it in the same proportion as their *Table A* amounts.

Water Quality - The salinity of the SWP water is generally in the range of 200 to 400 milligrams per liter of total dissolved solids. This is higher than the Kern River and the CVP-Friant water, but is still satisfactory for both municipal and irrigation purposes.

#### **4.2.7 Summary of Surface Water Supplies to the Region**

Over the last 25 years, the total of all surface water supplies entering the Poso Creek RMA has averaged about 775,000 acre-feet per year; however, after considering water that was banked for parties outside of the region, and not yet returned, this average is reduced to about 740,000 acre-feet. As shown on Figure 4-7, annual amounts have ranged from less than 400,000 acre-feet to over 1,000,000 acre-feet (which include water banked for out-of-region interests).

#### **4.2.8 Groundwater**

The present utilization of water supplies in the southern San Joaquin Valley is predominantly for irrigated agriculture, which is also true for the Poso Creek RMA. Most of the lands in the Poso Creek RMA are underlain by useable groundwater and, as a result, most of the irrigated agriculture was developed in reliance on pumped groundwater and some lands continue to rely exclusively on pumped groundwater. Accordingly, to the extent that surface water supplies are inadequate to meet irrigation water requirements, groundwater is used to make up the shortfall.

Water Levels - Under water supply conditions over the last 25 years, water levels have not evidenced an obvious long-term rise or decline; rather, they have gone up during *wet* periods and down during *dry* periods. This is illustrated on Figure 4-8, which presents average water levels for each of the districts within the RMA as well as the cumulative average annual change in regional water levels. While the depth range varies for each district, the trends are comparable. Figure 4-9 superimposes the Region’s surface water supplies on the average water levels for the Region.

.

Historical Surface Water Supplies by Source for the Poso Creek RMA

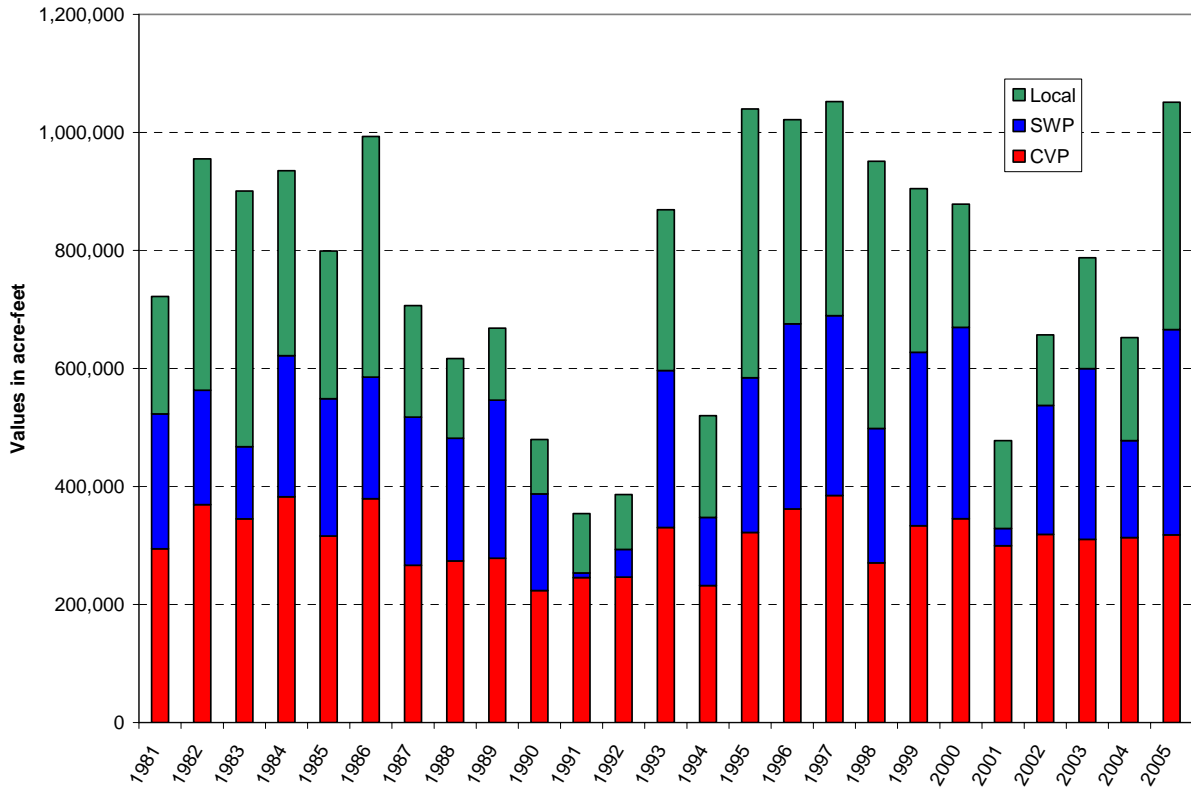

### Average Depth to Water

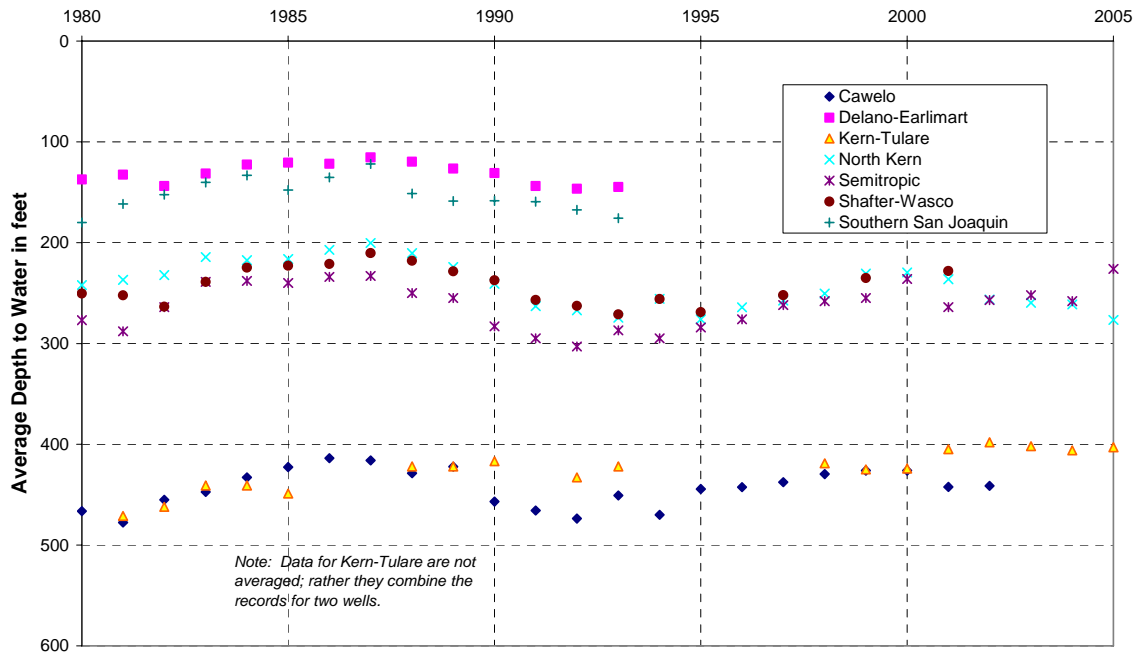

### Cumulative Average Annual Change in Regional Water Levels

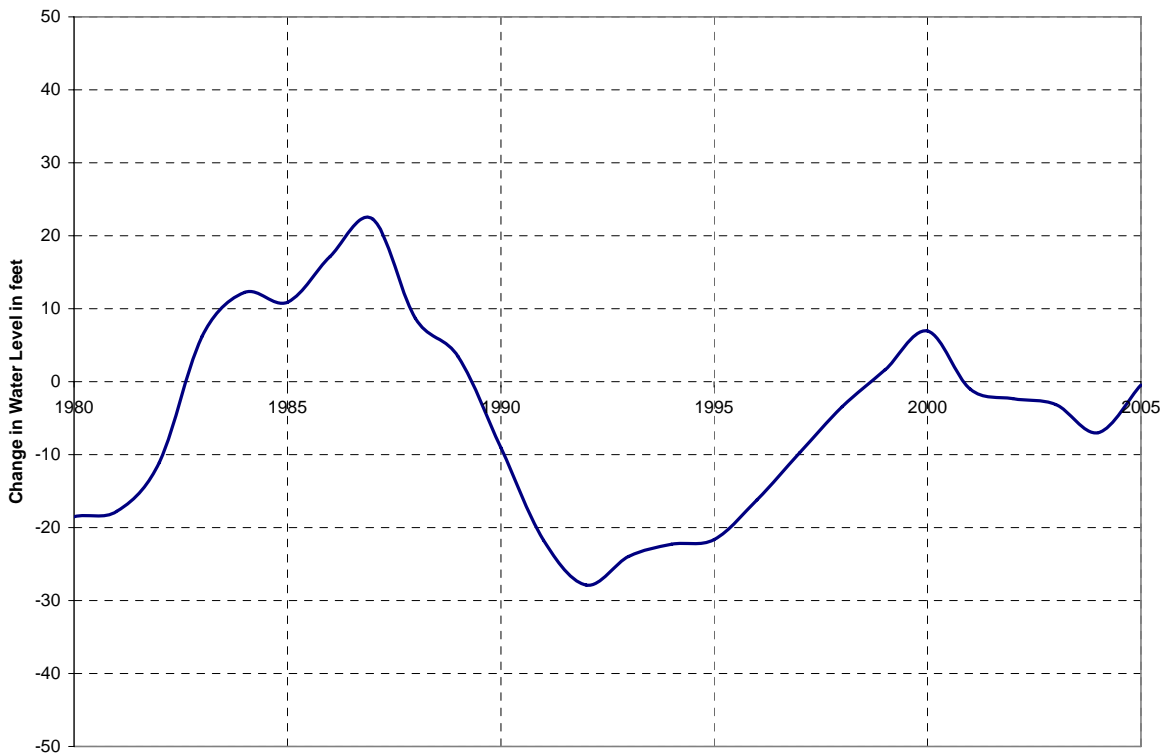

### Regional Surface Water Diversions and Water Level Changes

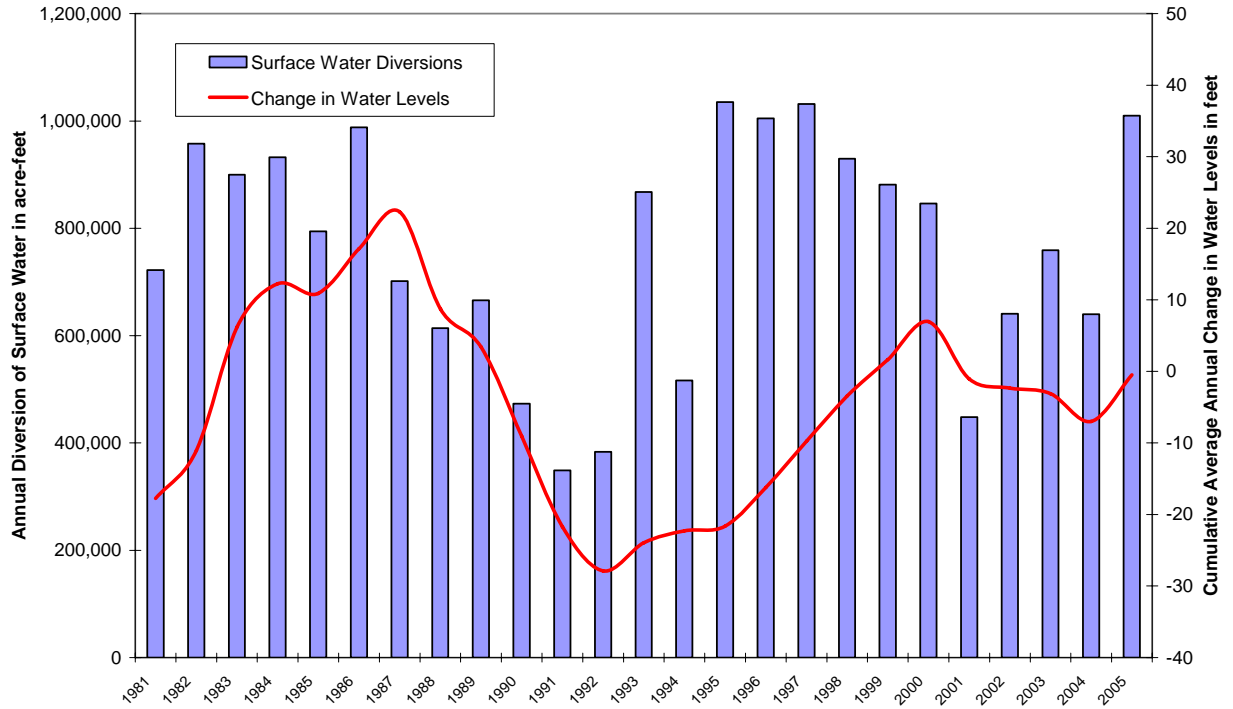

### 4.3 Projected Conditions

For the purpose of projecting future water supply conditions, the 73-year hydrologic period extending from 1922 through 1994 was used unless noted otherwise. This was the longest period for which the necessary data were available for each of the Region’s three principal sources of surface water. While averages for this period are not directly comparable to the historical averages for the 25-year period extending from 1981 through 2005 (presented in Section 4.2 above), the comparison is considered adequate for the purpose of characterizing the direction and magnitude of projected changes in surface water supplies going forward. This, in turn, will provide guidance respecting the groundwater-level response that could be expected in the future.

#### 4.3.1 Kern River

Kern River supplies available to the Poso Creek RMA can be expected to be less reliable in the future, as a result of 1) expiration of long-term agricultural water supply contracts in 2011, 2) ongoing water rights litigation, and 3) a storage restriction placed on Isabella Reservoir.

Agricultural Water Supply Contracts - In the mid 1970s, the City of Bakersfield entered into long-term water supply contracts which provided for the delivery of 70,000 acre-feet per year (average over the 35-year life of the contracts) into the Poso Creek RMA, with individual district contracts as summarized following:

Cawelo	27,000 af
Kern-Tulare	20,000
North Kern	20,000
Rag Gulch	<u>3,000</u>
Total for RMA	70,000 af

These contracts expire at the end of 2011 and the City of Bakersfield has advised that “the districts should be well into the planning and coordination of a replacement supply for any of the City Kern River water that may be needed by City for its use”<sup>4</sup>. Clearly, the worst case would be the loss of this source of supply in its entirety. However, it is likely that there will be years when the City will be unable to regulate the available supply and would make water available to these same districts for purchase. While it would also seem likely that the City’s need for this water would increase over time, which would suggest that this source of supply to the RMA would evidence a corresponding decrease over time, this remains speculative. Qualitatively, and in summary, less water will be available in total, the cost of water will

<sup>4</sup> City of Bakersfield letter dated August 17, 2006.

increase, and it will not be firm. For purposes of this regional planning effort, it was assumed that water would only be available during wetter years and that, on average over the long term, there would be a 50 percent reduction in this source of supply

Ongoing Litigation - Water rights litigation is ongoing and, while it remains speculative, it has the potential to result in less water being diverted into the Poso Creek RMA in the future than under historical conditions. In other words, the best case is probably maintenance of the status quo.

Storage Restriction - The maximum capacity of Isabella Reservoir is almost 570,000 acre-feet; however, in the spring of 2006, the United States Army Corps of Engineers (USACE), who is responsible for operation and maintenance, imposed a storage restriction of 350,000 acre-feet as a result of safety concerns. While the duration of the restriction is unknown at this time, it could be in place for many years. In drier years, this restriction will have little effect: however, in wetter years, full regulation of the available supply may be difficult, which could result in the loss of supply to the Poso Creek RMA. At a minimum, it would likely shift some water from being delivered directly to irrigation to being delivered to spreading. This would have the effect of shifting some of the regulation from Isabella Reservoir to the groundwater reservoir.

#### **4.3.2 Minor Streams**

Poso Creek, the namesake for this regional planning effort, is entirely controlled by members of the Regional Management Group. In particular, recall that Cawelo, North Kern, and Semitropic are all parties to an agreement respecting the use of the natural flow of Poso Creek. Accordingly, no changes are expected in this source of supply in the future, other than hydrologic changes, which are predicted in this report.

#### **4.3.3 Oilfield-Produced Water**

Fundamentally, this source of supply is a function of oil production in the Kern River field. North Kern has reduced its use of this supply and Cawelo has increased its use, both of which can be seen in the record of historical deliveries (reference Section 4.2.3).

North Kern - While North Kern used from 5,000 to 10,000 acre-feet annually between 1980 and the mid 1990s, their use has dropped to less than 1,000 acre-feet on average over the last few years. This recent level of use is considered to be representative of future conditions.

Cawelo - While Cawelo has received water from this source of supply since 1980, the level of use since the mid-1990s is considered to be representative of future conditions. In particular, it is projected that Cawelo will receive about 20,000 acre-feet annually. It is noteworthy that this supply is relatively *firm* inasmuch as it is a function of oil production and not of hydrology. The agreement between Cawelo and the operator of the Kern River

oilfield, under which deliveries are made to Cawelo, extends to 2026. This agreement provides that all oilfield-produced water be made available to Cawelo, except that which is used in the oilfield operations.

#### **4.3.4 Recycled Water**

The amount of water which is recycled from operations of the Kern National Wildlife Refuge is not expected to change in the future; it is expected to continue to range from 500 to 2,000 acre-feet annually. On the other hand, the amount of M&I wastewater effluent is expected to increase in the future as the population of the Region increases; accordingly, the amount of effluent which is recycled is expected to increase.

#### **4.3.5 Central Valley Project – Friant Division**

The reliability of CVP-Friant water is on the threshold of being significantly impacted. Litigation has surrounded this source of supply for many years, with the primary issue being the partial restoration of San Joaquin River flows below Friant Dam. In 2006, a settlement was reached, whereby some of the flows that historically would have been diverted to CVP-Friant contractors, will (in the future) be discharged to the river channel below Friant Dam. The effect of this settlement will be to significantly reduce the reliability of this source of supply, with the magnitude varying from year to year, depending on hydrology. During the development of the settlement, hydrologic modeling was conducted to develop and evaluate the terms of the settlement. This modeling of post-settlement operations was used as the basis for projections of future CVP-Friant supplies according to the three types of water: *Class 1*, *Class 2*, and *Other*.

*Class 1 and Class 2 Water* - Projected annual allocations of *Class 1* and *Class 2* water were obtained, and these data are presented in Table 4-5. To determine the projected availability of this source of supply to the Region, the *Class 1* and *Class 2* percent allocations (as shown in the table) are simply applied to the Class 1 and Class 2 contract amounts, respectively, for the CVP-Friant contractors in the Region; namely, Delano-Earlimart, Shafter-Wasco, and Southern San Joaquin. This results in a projected long-term average availability of 265,000 acre-feet per year. The percent allocations are presented on Figure 4-10, in terms of exceedance probability. This figure illustrates the exceedance probability of a given allocation. For example, based on this figure, it can be observed that a full Class 1 allocation can be expected in about 65 percent of the years (or between 6 and 7 years out of 10). The reduction in reliability of these supplies under the recent San Joaquin River settlement is illustrated on Figure 4-11.

Table 4-5

Projected Friant Class 1 and Class 2 Allocations  
Under Post-Settlement Conditions

Water Year	Friant-Kern Class 1 Allocation	Friant-Kern Class 2 Allocation
1922	100%	56%
1923	100%	21%
1924	39%	0%
1925	100%	6%
1926	98%	0%
1927	100%	34%
1928	100%	8%
1929	62%	0%
1930	60%	0%
1931	23%	0%
1932	100%	37%
1933	99%	0%
1934	50%	0%
1935	100%	25%
1936	100%	26%
1937	100%	42%
1938	100%	87%
1939	78%	0%
1940	100%	23%
1941	100%	56%
1942	100%	43%
1943	100%	28%
1944	100%	9%
1945	100%	41%
1946	100%	18%
1947	100%	1%
1948	79%	0%
1949	92%	0%
1950	100%	4%
1951	100%	4%
1952	100%	64%
1953	100%	1%
1954	100%	1%
1955	97%	0%
1956	100%	49%
1957	100%	16%
1958	100%	56%

Water Year	Friant-Kern Class 1 Allocation	Friant-Kern Class 2 Allocation
1959	93%	0%
1960	57%	0%
1961	41%	0%
1962	100%	30%
1963	100%	39%
1964	92%	0%
1965	100%	38%
1966	100%	6%
1967	100%	88%
1968	82%	0%
1969	100%	91%
1970	100%	14%
1971	100%	10%
1972	89%	0%
1973	100%	27%
1974	100%	37%
1975	100%	31%
1976	64%	0%
1977	23%	0%
1978	100%	84%
1979	100%	24%
1980	100%	58%
1981	100%	7%
1982	100%	73%
1983	100%	100%
1984	100%	26%
1985	100%	1%
1986	100%	53%
1987	65%	0%
1988	61%	0%
1989	61%	0%
1990	47%	0%
1991	67%	0%
1992	60%	0%
1993	100%	53%
1994	83%	0%

Average:  
(1922-1994)      91%      20%



**Exceedance Probability of Friant Class 1 and Class 2 Allocations Under Post-Settlement Conditions**

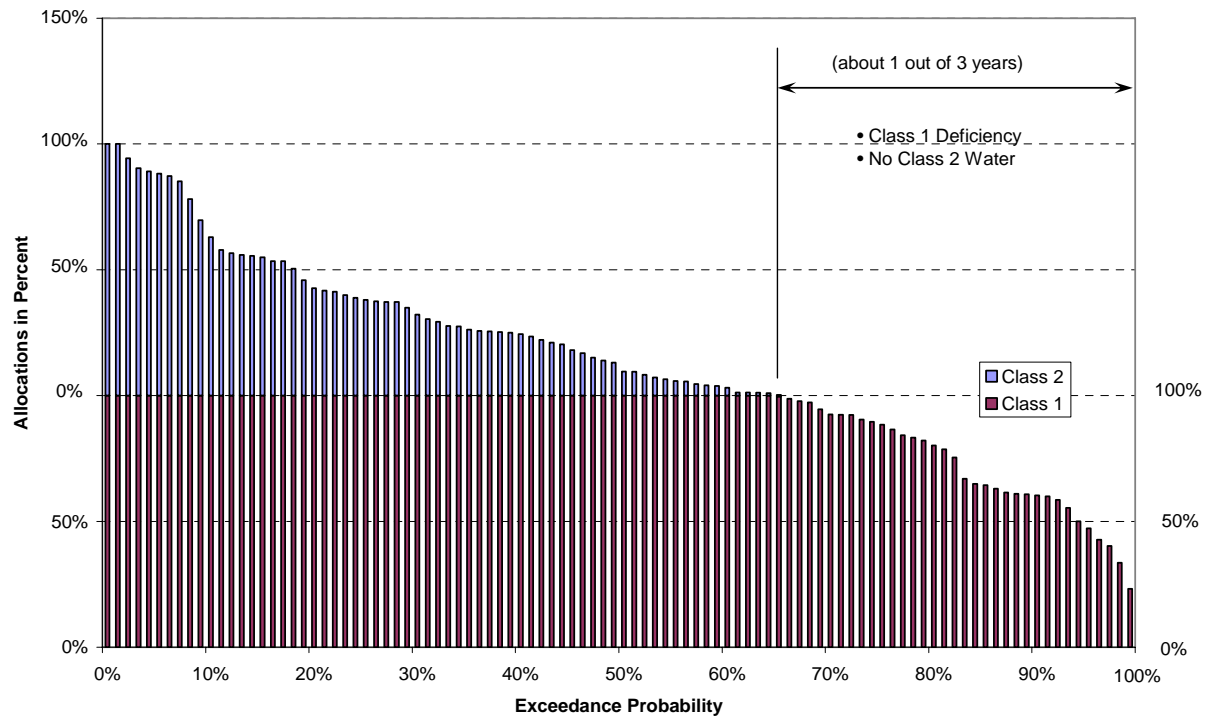

Exceedance Probability of Friant Class 1 Allocations

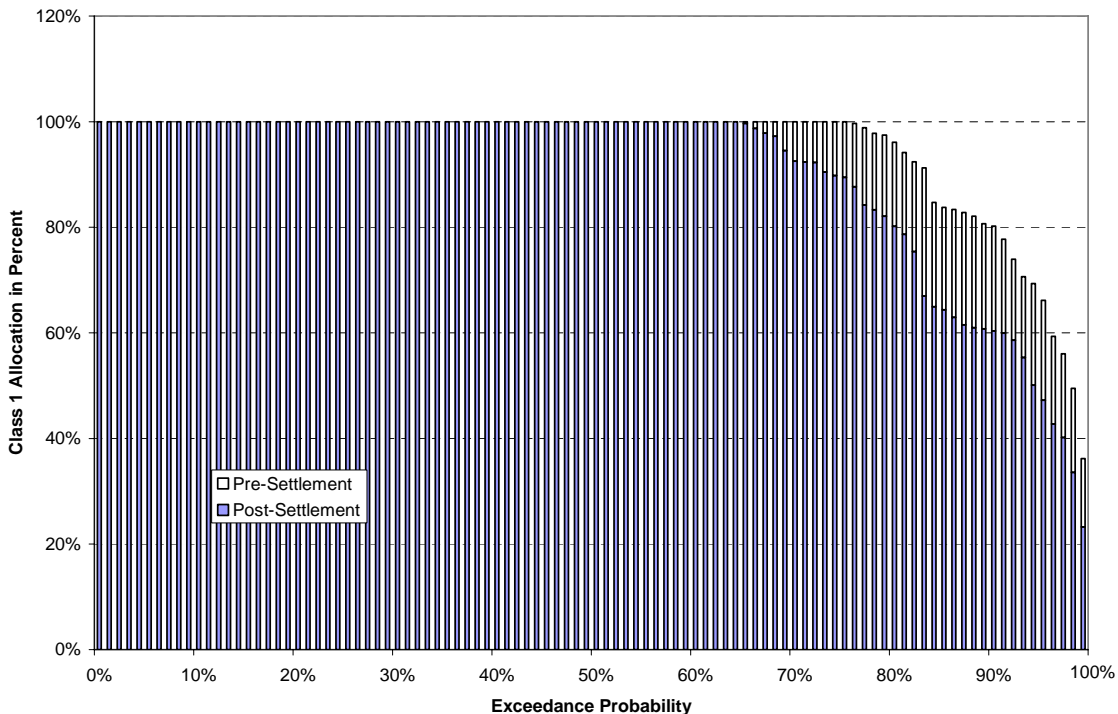

Exceedance Probability of Friant Class 2 Allocations

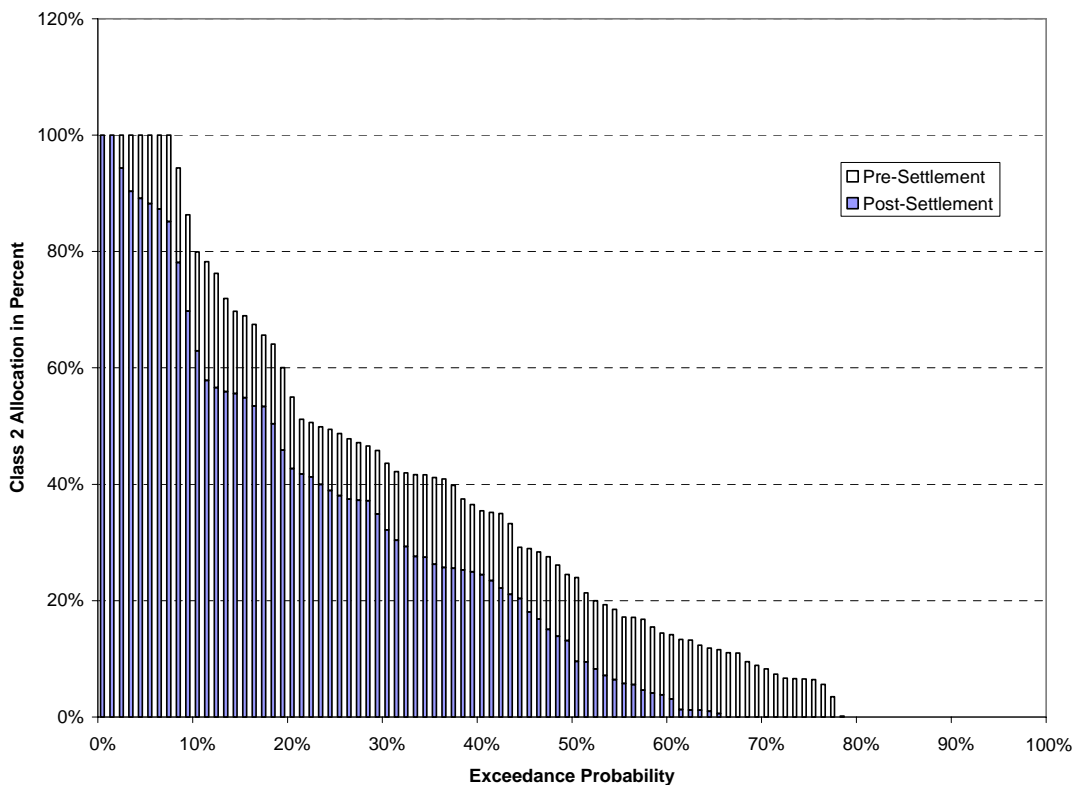
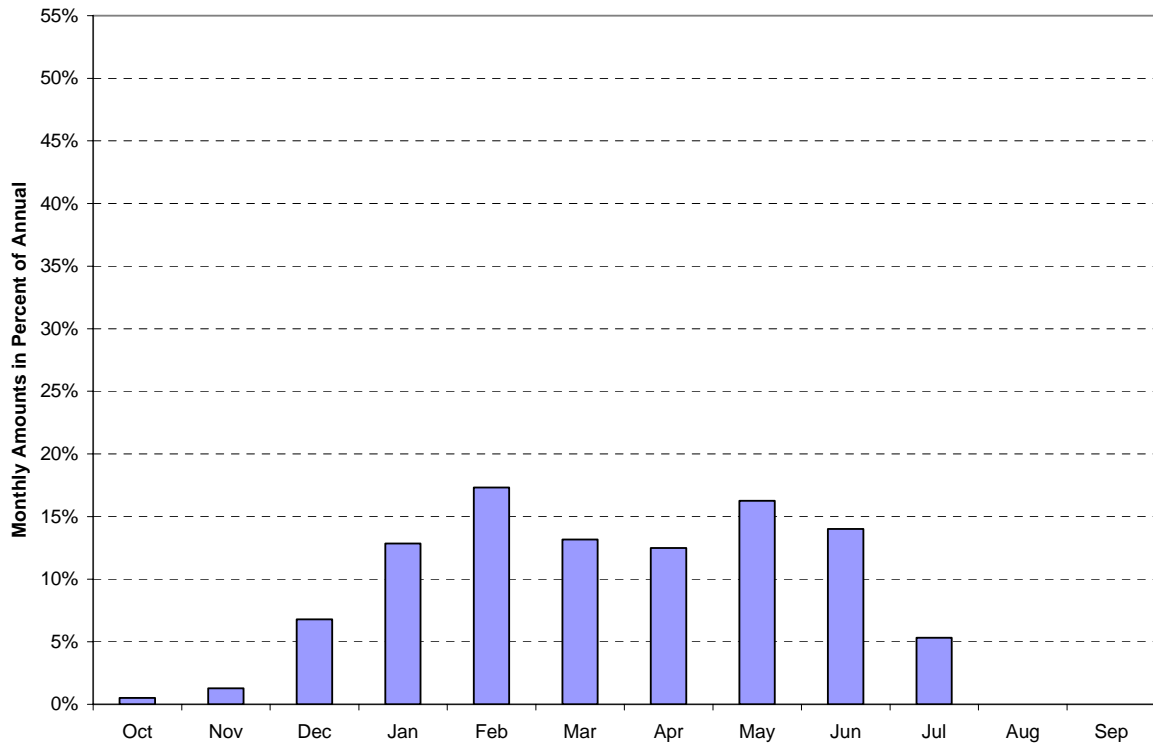

**Table 4-6**  
**Projected System-Wide Availability of "Other" Friant Water Under Post- Settlement Conditions**

(values in acre-feet)

Calendar Year	Jan	Feb	Mar	Apr	May	Jun	Jul	Aug	Sep	Oct	Nov	Dec	Total	Calendar Year
1922	36,000	92,000	86,000	77,000	86,000	5,000	0	0	0	0	0	0	382,000	1922
1923	0	0	0	0	0	0	0	0	0	0	0	0	0	1923
1924	0	0	0	0	0	0	0	0	0	0	0	0	0	1924
1925	0	0	0	0	0	0	0	0	0	0	0	0	0	1925
1926	0	0	0	0	0	0	0	0	0	0	0	0	0	1926
1927	0	0	0	0	0	25,000	0	0	0	0	0	0	25,000	1927
1928	0	0	0	0	13,000	0	0	0	0	0	0	0	13,000	1928
1929	0	0	0	0	0	0	0	0	0	0	0	0	0	1929
1930	0	0	0	0	0	0	0	0	0	0	0	0	0	1930
1931	0	1,000	0	0	0	0	0	0	0	0	0	0	1,000	1931
1932	0	0	0	0	0	0	0	0	0	0	0	0	0	1932
1933	0	0	0	0	0	0	0	0	0	0	0	0	0	1933
1934	0	0	0	0	0	0	0	0	0	0	0	0	0	1934
1935	0	0	0	0	0	0	0	0	0	0	0	0	0	1935
1936	0	43,000	4,000	3,000	60,000	13,000	0	0	0	0	0	0	123,000	1936
1937	0	106,000	101,000	115,000	99,000	30,000	0	0	0	0	0	0	451,000	1937
1938	20,000	190,000	237,000	218,000	317,000	237,000	109,000	0	0	0	0	0	1,328,000	1938
1939	0	0	0	0	0	0	0	0	0	0	0	0	0	1939
1940	0	0	0	0	3,000	45,000	0	0	0	0	0	0	48,000	1940
1941	0	106,000	16,000	77,000	63,000	0	0	0	0	0	0	0	262,000	1941
1942	66,000	60,000	0	0	84,000	20,000	0	0	0	0	0	0	230,000	1942
1943	124,000	87,000	91,000	16,000	61,000	7,000	0	0	0	0	0	0	386,000	1943
1944	0	0	0	0	0	0	0	0	0	0	0	0	0	1944
1945	0	109,000	0	0	0	0	0	0	0	0	0	61,000	170,000	1945
1946	80,000	10,000	0	0	30,000	0	0	0	0	0	0	0	120,000	1946
1947	0	18,000	0	0	0	0	0	0	0	0	0	0	18,000	1947
1948	0	0	0	0	0	0	0	0	0	0	0	0	0	1948
1949	0	0	0	0	0	0	0	0	0	0	0	0	0	1949
1950	0	0	0	0	0	0	0	0	0	0	0	267,000	267,000	1950
1951	136,000	93,000	0	0	0	0	0	0	0	0	0	0	229,000	1951
1952	0	39,000	119,000	98,000	89,000	130,000	16,000	0	0	0	0	0	491,000	1952
1953	0	0	0	0	0	0	0	0	0	0	0	0	0	1953
1954	0	0	0	0	0	0	0	0	0	0	0	0	0	1954
1955	0	0	0	0	0	0	0	0	0	0	0	132,000	132,000	1955
1956	257,000	95,000	30,000	0	0	0	0	0	0	0	0	0	382,000	1956
1957	0	0	0	0	0	0	0	0	0	0	0	0	0	1957
1958	0	0	6,000	104,000	76,000	55,000	0	0	0	0	0	0	241,000	1958
1959	0	0	0	0	0	0	0	0	0	0	0	0	0	1959
1960	0	0	0	0	0	0	0	0	0	0	0	0	0	1960
1961	0	0	0	0	0	0	0	0	0	0	0	0	0	1961
1962	0	0	0	0	0	0	0	0	0	0	0	0	0	1962
1963	0	59,000	0	0	0	0	0	0	0	0	0	0	59,000	1963
1964	0	0	0	0	0	0	0	0	0	0	0	0	0	1964
1965	92,000	101,000	0	0	0	0	0	0	0	0	0	0	193,000	1965
1966	50,000	9,000	0	11,000	58,000	0	0	0	0	0	0	10,000	138,000	1966
1967	77,000	79,000	90,000	97,000	15,000	269,000	0	0	0	0	0	0	627,000	1967
1968	0	0	0	0	0	0	0	0	0	0	0	117,000	117,000	1968
1969	184,000	223,000	246,000	317,000	320,000	134,000	0	0	0	0	0	0	1,424,000	1969
1970	0	0	0	0	0	0	0	0	0	0	0	0	0	1970
1971	0	0	0	0	0	0	0	0	0	0	0	0	0	1971
1972	0	0	0	0	0	0	0	0	0	0	0	0	0	1972
1973	0	0	1,000	0	7,000	102,000	0	0	0	0	0	0	110,000	1973
1974	129,000	35,000	34,000	72,000	65,000	27,000	0	0	0	0	0	0	362,000	1974
1975	0	0	0	0	0	0	0	0	0	0	0	0	0	1975
1976	0	0	0	0	0	0	0	0	0	0	0	0	0	1976
1977	0	0	0	0	0	0	0	0	0	0	0	0	0	1977
1978	0	129,000	108,000	93,000	168,000	113,000	130,000	0	0	0	0	0	741,000	1978
1979	35,000	0	26,000	0	40,000	46,000	0	0	0	0	0	0	147,000	1979
1980	178,000	204,000	38,000	0	95,000	91,000	109,000	0	0	0	0	0	715,000	1980
1981	26,000	12,000	0	0	0	0	0	0	0	0	0	0	38,000	1981
1982	0	96,000	90,000	128,000	184,000	158,000	22,000	0	0	74,000	125,000	192,000	1,069,000	1982
1983	218,000	205,000	349,000	185,000	239,000	409,000	371,000	0	0	0	57,000	184,000	2,217,000	1983
1984	118,000	4,000	14,000	0	0	0	0	0	0	0	0	0	136,000	1984
1985	0	0	0	0	0	0	0	0	0	0	0	0	0	1985
1986	0	239,000	185,000	85,000	74,000	76,000	0	0	0	0	0	0	659,000	1986
1987	0	0	0	0	0	0	0	0	0	0	0	0	0	1987
1988	0	0	0	0	0	0	0	0	0	0	0	0	0	1988
1989	0	0	0	0	0	0	0	0	0	0	0	0	0	1989
1990	0	0	0	0	0	0	0	0	0	0	0	0	0	1990
1991	0	0	0	0	0	0	0	0	0	0	0	0	0	1991
1992	0	0	0	0	0	0	0	0	0	0	0	0	0	1992
1993	0	16,000	0	79,000	63,000	0	0	0	0	0	0	0	158,000	1993
1994	0	0	0	0	0	0	0	0	0	0	0	0	0	1994
<b>Average:</b> <b>(1922-1994)</b>	25,000	33,700	25,600	24,300	31,600	27,300	10,400	0	0	1,000	2,500	13,200	194,600	

**Average Monthly Distribution of "Other" Friant Water Under Post-Settlement Conditions**



*Other Water* - Data respecting the projected monthly availability of *Other* Friant water were obtained, and they are presented in Table 4-6 and the average monthly availability pattern is illustrated in Figure 4-12. These data reflect the system-wide availability of this type of water at Friant Dam. To determine the minimum amount of this type of water available to the Region, it was assumed that a given contractor’s minimum “share” could be approximated as the contractor’s Class 2 contract amount divided by the total of the Class 2 amounts for all contractors (i.e., 1,400,000 af). Accordingly, these factors are summarized as follows:

Delano-Earlimart	5.3%
Shafter-Wasco	2.8%
Southern San Joaquin	<u>3.6%</u>
Total for RMA	11.7%

Applying 11.7 percent to the average annual system-wide availability of about 195,000 acre-feet, results in about 23,000 acre-feet.

**4.3.6 Central Valley Project – Delta Division**

The reliability of delivery of CVP-Delta supplies has already been severely impacted. The significant reduction in reliability of this source of supply is a result of regulatory restrictions on pumping from the Delta, particularly since 1991. Wheeling CVP-Delta water in the California Aqueduct is second in priority to SWP purposes. Accordingly, any time there is a regulatory constraint on pumping from the Delta for SWP purposes, there is no pumping capacity to move CVP-Delta water into the Aqueduct for wheeling. Prior to 1991, the long-term average annual CVP-Delta allocation was about 95 percent, indicating a very *firm* supply. Since that time however, the long-term average allocation has been reduced to less than 60 percent. This significant loss of water supply reliability is particularly apparent when considering a repeat of the 1987-1992 drought period. While allocations during this six-year drought ranged from a little less than 50 percent to about 65 percent, it is projected that allocations during a repeat of this hydrology would range from zero (in two of the six years) to about 32 percent.

**4.3.7 State Water Project**

The fact that the State Water Project remains incomplete has adversely impacted the reliability of this source of supply. In addition, environmental and water quality issues in and surrounding the Sacramento-San Joaquin River Delta (Delta) have limited the ability to export water south of the Delta, which has further reduced the reliability of SWP water supplies available to the Region. The last *Delivery Reliability Report* for the State Water Project was published by DWR in April 2006; accordingly, these data were used as the basis

for projecting the future availability of this source of supply<sup>5</sup>. Two studies were presented in that report, which are referred to as *Study 4* and *Study 5*, and reflect 2005 and 2025 level of SWP demand, respectively. Data are included for both *Table A water* and *Article 21 water*. Under 2025 conditions, deliveries of *Table A water* are shown to increase relative to 2005; however, there is a corresponding decrease in the availability of *Article 21 water*. Deliveries of *Table A water* are shown to reach a minimum of four to five percent in Studies 4 and 5, whereas projections which were made three years earlier showed the minimum delivery at about 19 to 20 percent. The 2006 report suggests that this significant reduction in reliability is primarily attributable to a change in the *delivery-carryover storage rule*.

*Table A Water* - The projected allocation of *Table A water* for each year is presented in Table 4-7, for the 1922-1994 hydrologic period. To determine the projected availability of this source of supply to the Region, these allocations, expressed as a percentage, are applied to the maximum *Table A* amount for each of the SWP contractors in the Region; namely, Cawelo and Semitropic. This results in a long-term average of about 131,000 acre-feet under *Study 4*, or almost 147,000 acre-feet under *Study 5*

*Article 21 Water* - The projected monthly availability of *Article 21 water* is presented in Tables 4-8 and 4-9, for the 1922-1994 hydrologic period. Figures 4-13 and 4-14 show the annual and monthly distribution of these supplies, respectively. These data reflect the system-wide availability of this type of water at the Delta. To determine the minimum amount of this type of water available to the Region, it was assumed that a given contractor’s minimum “share” could be approximated by the contractor’s maximum *Table A* amount divided by the total of the *Table A* amounts for all contractors. Accordingly, these factors are summarized as follows for the Poso Creek RMA:

Cawelo	0.92%
Semitropic	<u>3.75</u>
Total for RMA	4.67%

Applying 4.67 percent to the average annual system-wide availability of about 262,000 acre-feet, results in about 12,000 acre-feet (under *Study 4*).

---

<sup>5</sup> It is understood that an updated report may be available in the fall of 2007.

Table 4-7

Projected SWP Table A Allocations  
Under CalSim II "Study 4" and "Study 5"

Calendar Year	Delivery as a Percentage of Max. Table A (Study 4)	Delivery as a Percentage of Max. Table A (Study 5)
1922	91%	100%
1923	79%	100%
1924	30%	9%
1925	45%	36%
1926	72%	66%
1927	93%	100%
1928	82%	82%
1929	27%	27%
1930	69%	66%
1931	25%	26%
1932	34%	38%
1933	32%	32%
1934	37%	36%
1935	91%	98%
1936	86%	90%
1937	81%	82%
1938	81%	100%
1939	79%	83%
1940	78%	100%
1941	61%	95%
1942	77%	100%
1943	75%	92%
1944	75%	86%
1945	75%	94%
1946	78%	93%
1947	80%	67%
1948	71%	71%
1949	55%	49%
1950	77%	82%
1951	85%	100%
1952	63%	95%
1953	80%	100%
1954	80%	100%
1955	53%	36%
1956	87%	100%
1957	78%	86%
1958	72%	100%

Calendar Year	Delivery as a Percentage of Max. Table A (Study 4)	Delivery as a Percentage of Max. Table A (Study 5)
1959	84%	92%
1960	45%	39%
1961	64%	66%
1962	79%	80%
1963	92%	100%
1964	80%	70%
1965	74%	84%
1966	79%	100%
1967	71%	100%
1968	81%	92%
1969	64%	95%
1970	79%	100%
1971	81%	100%
1972	81%	66%
1973	75%	98%
1974	77%	100%
1975	78%	100%
1976	79%	76%
1977	4%	5%
1978	87%	94%
1979	85%	91%
1980	66%	85%
1981	81%	92%
1982	70%	100%
1983	60%	95%
1984	67%	100%
1985	78%	83%
1986	56%	69%
1987	70%	80%
1988	21%	10%
1989	77%	85%
1990	27%	21%
1991	25%	21%
1992	34%	35%
1993	93%	100%
1994	80%	76%

Average:  
(1922-1994) 68% 76%

**Table 4-8**  
**Projected System-Wide Availability of SWP "Article 21" Water Under CalSim II - "Study 4"**

(values in acre-feet)

Calendar Year	Jan	Feb	Mar	Apr	May	Jun	Jul	Aug	Sep	Oct	Nov	Dec	Total	Calendar Year
1922	0	0	87,900	16,000	0	0	0	0	0	0	0	0	103,900	1922
1923	52,900	53,400	0	0	0	0	0	0	0	0	0	0	106,300	1923
1924	0	0	0	0	0	0	0	0	0	0	0	0	0	1924
1925	0	0	0	0	0	0	0	0	0	0	0	0	0	1925
1926	0	54,300	0	0	0	0	0	0	0	0	0	0	54,300	1926
1927	0	52,800	160,500	0	0	0	0	0	0	0	0	0	213,300	1927
1928	0	0	118,300	15,500	0	0	0	0	0	0	0	0	133,800	1928
1929	0	0	0	0	0	0	0	0	0	0	0	0	0	1929
1930	0	0	116,800	0	0	0	0	0	0	0	0	0	116,800	1930
1931	0	0	0	0	0	0	0	0	0	0	0	0	0	1931
1932	0	97,800	144,600	0	0	0	0	0	0	0	0	0	242,400	1932
1933	179,300	148,800	184,000	0	0	0	0	0	0	0	0	0	512,100	1933
1934	21,700	184,000	0	0	0	0	0	0	0	0	0	0	205,700	1934
1935	0	0	184,000	45,100	0	0	0	0	0	0	0	0	229,100	1935
1936	0	0	0	0	0	0	0	0	0	0	0	0	0	1936
1937	0	0	18,800	59,900	800	0	0	0	0	0	0	0	79,500	1937
1938	0	141,500	184,000	80,600	67,400	0	0	0	0	41,900	17,900	180,300	713,600	1938
1939	184,000	90,400	75,000	0	0	0	0	0	0	0	0	0	349,400	1939
1940	0	0	129,700	24,600	0	0	0	0	0	0	0	0	154,300	1940
1941	0	45,700	100,000	0	0	0	0	0	0	0	0	100,000	245,700	1941
1942	184,000	184,000	184,000	51,900	0	0	0	0	0	58,300	78,000	178,000	918,200	1942
1943	184,000	184,000	184,000	71,100	0	0	0	0	0	0	0	0	623,100	1943
1944	0	0	0	0	0	0	0	0	0	0	0	0	0	1944
1945	0	175,000	184,000	0	0	0	0	0	0	0	0	0	359,000	1945
1946	176,000	0	72,700	0	0	0	0	0	0	0	0	0	248,700	1946
1947	0	0	0	0	0	0	0	0	0	0	0	0	0	1947
1948	0	0	0	0	0	0	0	0	0	0	0	0	0	1948
1949	0	0	0	0	0	0	0	0	0	0	0	0	0	1949
1950	0	0	0	0	0	0	0	0	0	0	0	0	0	1950
1951	20,200	184,000	184,000	0	0	0	0	0	0	0	0	0	388,200	1951
1952	0	75,000	100,000	0	0	0	0	0	0	0	0	100,000	275,000	1952
1953	184,000	144,900	184,000	0	0	0	0	0	0	0	0	0	512,900	1953
1954	144,900	184,000	184,000	9,800	0	0	0	0	0	0	0	0	522,700	1954
1955	0	0	0	0	0	0	0	0	0	0	0	0	0	1955
1956	0	140,300	184,000	0	0	0	0	0	0	0	0	0	324,300	1956
1957	0	72,500	184,000	0	0	0	0	0	0	0	0	0	256,500	1957
1958	178,000	184,000	184,000	80,600	70,600	26,200	0	71,100	78,000	56,300	177,300	1,106,100	1958	
1959	184,000	181,800	0	0	0	0	0	0	0	0	0	0	365,800	1959
1960	0	0	0	0	0	0	0	0	0	0	0	0	0	1960
1961	0	0	97,000	0	0	0	0	0	0	0	0	0	97,000	1961
1962	0	0	0	0	0	0	0	0	0	0	0	0	0	1962
1963	0	0	181,900	20,200	0	0	0	0	0	0	0	0	202,100	1963
1964	0	0	0	0	0	0	0	0	0	0	0	0	0	1964
1965	0	11,400	104,800	60,500	0	0	0	0	0	0	0	0	176,700	1965
1966	149,500	184,000	184,000	0	0	0	0	0	0	0	0	0	517,500	1966
1967	0	127,600	184,000	80,800	78,000	28,700	0	10,000	78,000	78,000	78,000	180,300	923,400	1967
1968	184,000	184,000	184,000	0	0	0	0	0	0	0	0	0	552,000	1968
1969	0	74,600	100,000	0	0	0	0	0	0	0	0	100,000	274,600	1969
1970	184,000	184,000	184,000	0	0	0	0	0	0	0	0	0	552,000	1970
1971	0	0	0	0	0	0	0	0	0	0	0	0	0	1971
1972	73,000	157,000	184,000	0	0	0	0	0	0	0	0	0	414,000	1972
1973	0	67,700	184,000	12,500	0	0	0	0	0	0	0	119,600	383,800	1973
1974	184,000	184,000	184,000	63,800	0	0	0	0	0	0	60,200	178,000	854,000	1974
1975	184,000	184,000	184,000	41,300	0	0	0	0	0	53,400	78,000	178,000	902,700	1975
1976	184,000	5,300	0	0	0	0	0	0	0	0	0	0	189,300	1976
1977	0	0	0	0	0	0	0	0	0	0	0	0	0	1977
1978	100,000	100,000	100,000	0	0	0	0	0	0	0	0	0	300,000	1978
1979	0	0	160,300	0	0	0	0	0	0	0	0	0	160,300	1979
1980	0	38,000	100,000	0	0	0	0	0	0	0	0	0	138,000	1980
1981	178,000	184,000	184,000	0	0	0	0	0	0	0	0	0	546,000	1981
1982	0	114,800	184,000	80,700	78,000	6,800	0	0	0	78,000	78,000	180,300	800,600	1982
1983	100,000	100,000	100,000	0	0	0	0	0	0	0	0	100,000	400,000	1983
1984	184,000	184,000	184,000	0	0	0	0	0	0	0	0	0	552,000	1984
1985	0	0	0	0	0	0	0	0	0	0	0	0	0	1985
1986	0	20,300	100,000	0	0	0	0	0	0	0	0	0	120,300	1986
1987	178,000	184,000	184,000	0	0	0	0	0	0	0	0	0	546,000	1987
1988	0	0	0	0	0	0	0	0	0	0	0	0	0	1988
1989	0	0	0	0	0	0	0	0	0	0	0	0	0	1989
1990	0	0	0	0	0	0	0	0	0	0	0	0	0	1990
1991	0	0	0	0	0	0	0	0	0	0	0	0	0	1991
1992	0	0	0	0	0	0	0	0	0	0	0	0	0	1992
1993	0	0	158,500	0	0	0	0	0	0	0	0	0	158,500	1993
1994	0	0	0	0	0	0	0	0	0	0	0	0	0	1994
<b>Average:</b> <b>(1922-1994)</b>	49,000	66,700	92,400	11,200	4,000	900	0	100	2,000	5,300	6,100	24,300	262,000	

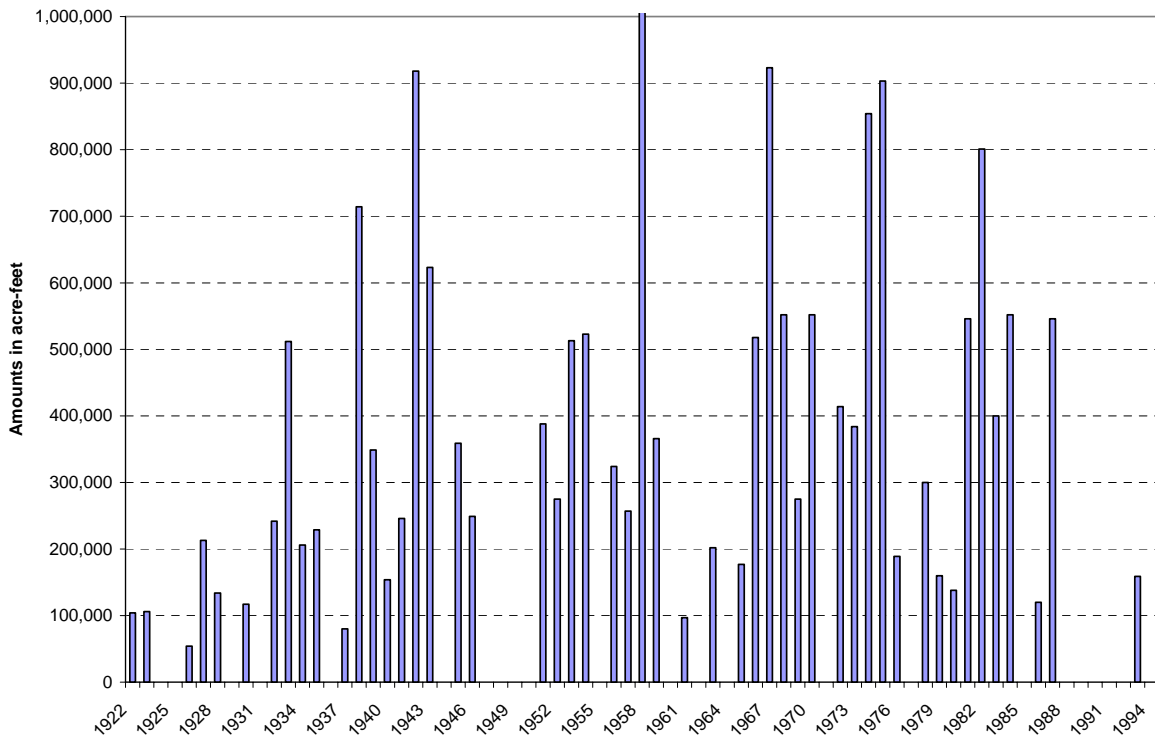

**Table 4-9  
Projected System-Wide Availability of SWP "Article 21" Water Under CalSim II - "Study 5"**

(values in acre-feet)

Calendar Year	Jan	Feb	Mar	Apr	May	Jun	Jul	Aug	Sep	Oct	Nov	Dec	Total	Calendar Year
1922	0	0	20,600	0	0	0	0	0	0	0	0	0	20,600	1922
1923	0	0	0	0	0	0	0	0	0	0	0	0	0	1923
1924	0	0	0	0	0	0	0	0	0	0	0	0	0	1924
1925	0	182,600	0	3,700	4,200	0	0	0	0	0	0	0	190,500	1925
1926	0	181,000	14,200	84,000	0	0	0	0	0	0	0	0	279,200	1926
1927	0	158,200	143,100	0	0	0	0	0	0	0	0	0	301,300	1927
1928	0	0	0	0	0	0	0	0	0	0	0	0	0	1928
1929	0	0	0	0	0	0	0	0	0	0	0	0	0	1929
1930	0	0	140,800	0	0	0	0	0	0	0	0	0	140,800	1930
1931	0	0	0	0	0	0	0	0	0	0	0	0	0	1931
1932	0	0	111,500	0	0	0	0	0	0	0	0	0	111,500	1932
1933	179,200	184,000	184,000	0	0	0	0	0	0	0	0	0	547,200	1933
1934	58,300	184,000	0	0	0	0	0	0	0	0	0	0	242,300	1934
1935	0	0	184,000	34,400	0	0	0	0	0	0	0	0	218,400	1935
1936	0	0	0	0	0	0	0	0	0	0	0	0	0	1936
1937	0	0	0	55,900	14,200	0	0	0	0	0	0	0	70,100	1937
1938	0	0	122,400	78,000	0	0	0	0	0	0	0	0	200,400	1938
1939	0	0	0	0	0	0	0	0	0	0	0	0	0	1939
1940	0	0	113,900	0	0	0	0	0	0	0	0	0	113,900	1940
1941	0	0	0	0	0	0	0	0	0	0	0	0	0	1941
1942	0	0	122,900	0	0	0	0	0	0	0	0	0	122,900	1942
1943	148,800	146,100	161,200	31,200	0	0	0	0	0	0	0	0	487,300	1943
1944	0	0	0	0	0	0	0	0	0	0	0	0	0	1944
1945	0	0	118,100	0	0	0	0	0	0	0	0	0	118,100	1945
1946	0	0	0	0	0	0	0	0	0	0	0	0	0	1946
1947	0	0	0	0	0	0	0	0	0	0	0	0	0	1947
1948	0	0	0	0	0	0	0	0	0	0	0	0	0	1948
1949	0	0	0	0	0	0	0	0	0	0	0	0	0	1949
1950	0	0	0	0	0	0	0	0	0	0	0	0	0	1950
1951	0	101,200	150,500	0	0	0	0	0	0	0	0	0	251,700	1951
1952	0	0	0	0	0	0	0	0	0	0	0	0	0	1952
1953	151,300	0	144,700	0	0	0	0	0	0	0	0	0	296,000	1953
1954	0	0	0	0	0	0	0	0	0	0	0	0	0	1954
1955	0	0	0	0	0	0	0	0	0	0	0	0	0	1955
1956	39,300	159,000	154,000	0	0	0	0	0	0	0	0	0	352,300	1956
1957	0	0	0	0	0	0	0	0	0	0	0	0	0	1957
1958	0	35,100	147,600	46,400	0	0	0	0	0	0	0	0	229,100	1958
1959	0	106,500	0	0	0	0	0	0	0	0	0	0	106,500	1959
1960	0	0	0	0	0	0	0	0	0	0	0	0	0	1960
1961	0	161,000	138,300	0	0	0	0	0	0	0	0	0	299,300	1961
1962	0	0	1,200	0	0	0	0	0	0	0	0	0	1,200	1962
1963	0	0	161,200	0	0	0	0	0	0	0	0	0	161,200	1963
1964	0	0	0	0	0	0	0	0	0	0	0	0	0	1964
1965	0	0	14,100	32,400	0	0	0	0	0	0	0	0	46,500	1965
1966	0	27,000	151,400	0	0	0	0	0	0	0	0	0	178,400	1966
1967	0	0	108,400	48,600	0	0	0	0	0	0	0	0	157,000	1967
1968	143,600	156,300	165,400	0	0	0	0	0	0	0	0	0	465,300	1968
1969	0	0	61,800	0	0	0	0	0	0	0	0	900	62,700	1969
1970	178,000	145,800	169,500	0	0	0	0	0	0	0	0	0	493,300	1970
1971	0	0	0	0	0	0	0	0	0	0	0	0	0	1971
1972	0	0	0	0	0	0	0	0	0	0	0	0	0	1972
1973	0	111,400	147,300	0	0	0	0	0	0	0	0	0	258,700	1973
1974	0	0	69,400	0	0	0	0	0	0	0	0	0	69,400	1974
1975	0	0	133,800	0	0	0	0	0	0	0	0	0	133,800	1975
1976	0	0	0	0	0	0	0	0	0	0	0	0	0	1976
1977	0	0	0	0	0	0	0	0	0	0	0	0	0	1977
1978	100,000	100,000	100,000	0	0	0	0	0	0	0	0	0	300,000	1978
1979	0	0	143,500	0	0	0	0	0	0	0	0	0	143,500	1979
1980	0	0	85,900	0	0	0	0	0	0	0	0	0	85,900	1980
1981	0	0	71,100	0	0	0	0	0	0	0	0	0	71,100	1981
1982	0	0	57,200	60,300	0	0	0	0	0	0	0	53,500	171,000	1982
1983	100,000	91,400	93,800	0	0	0	0	0	0	0	0	72,200	357,400	1983
1984	178,000	162,700	149,200	0	0	0	0	0	0	0	0	0	489,900	1984
1985	0	0	0	0	0	0	0	0	0	0	0	0	0	1985
1986	0	0	83,200	0	0	0	0	0	0	0	0	0	83,200	1986
1987	0	0	183,000	0	0	0	0	0	0	0	0	0	183,000	1987
1988	0	0	0	0	0	0	0	0	0	0	0	0	0	1988
1989	0	0	91,400	0	0	0	0	0	0	0	0	0	91,400	1989
1990	0	0	0	0	0	0	0	0	0	0	0	0	0	1990
1991	0	0	0	0	0	0	0	0	0	0	0	0	0	1991
1992	0	0	101,700	0	0	0	0	0	0	0	0	0	101,700	1992
1993	0	112,400	142,300	0	0	0	0	0	0	0	0	0	254,700	1993
1994	0	0	0	0	0	0	0	0	0	0	0	0	0	1994
<b>Average:</b>														
<b>(1922-1994)</b>	<b>17,500</b>	<b>34,300</b>	<b>63,800</b>	<b>6,500</b>	<b>300</b>	<b>0</b>	<b>0</b>	<b>0</b>	<b>0</b>	<b>0</b>	<b>0</b>	<b>1,700</b>	<b>124,100</b>	

Projected System-Wide Availability of SWP "Article 21" Water Under CalSim II - "Study 4"



Projected System-Wide Availability of SWP "Article 21" Water Under CalSim II - "Study 5"

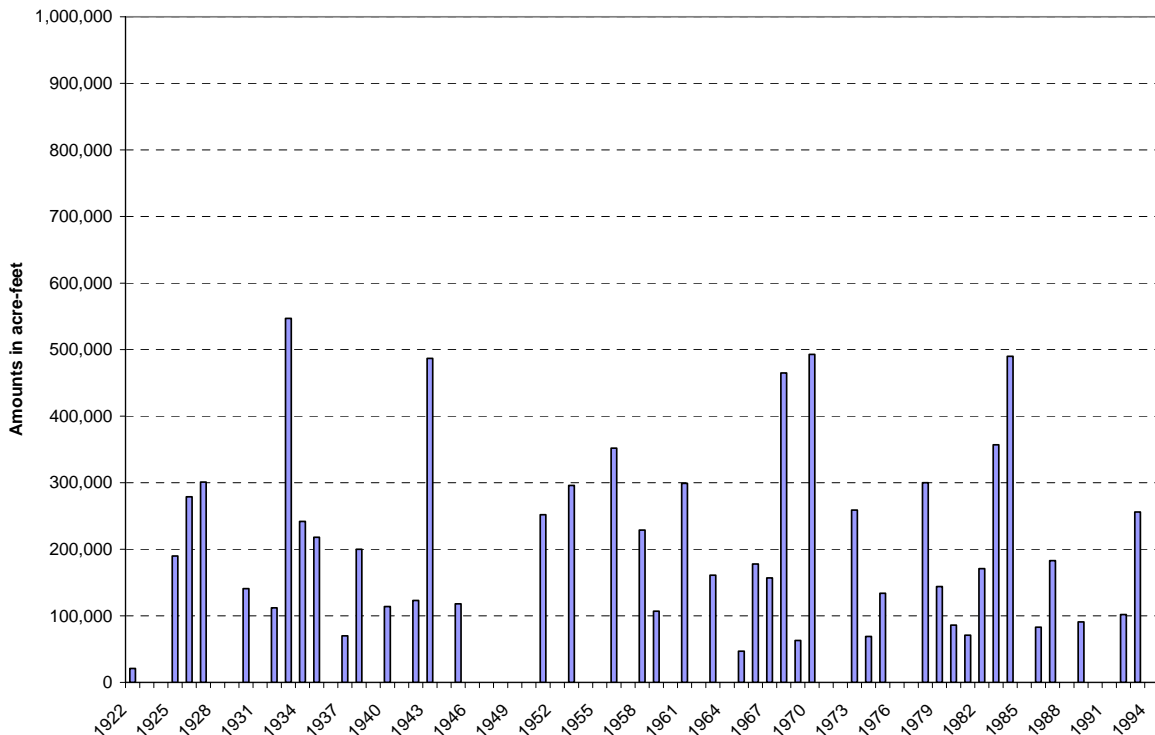

Average Monthly Distribution of SWP "Article 21" Water Under CalSim II - "Study 4"

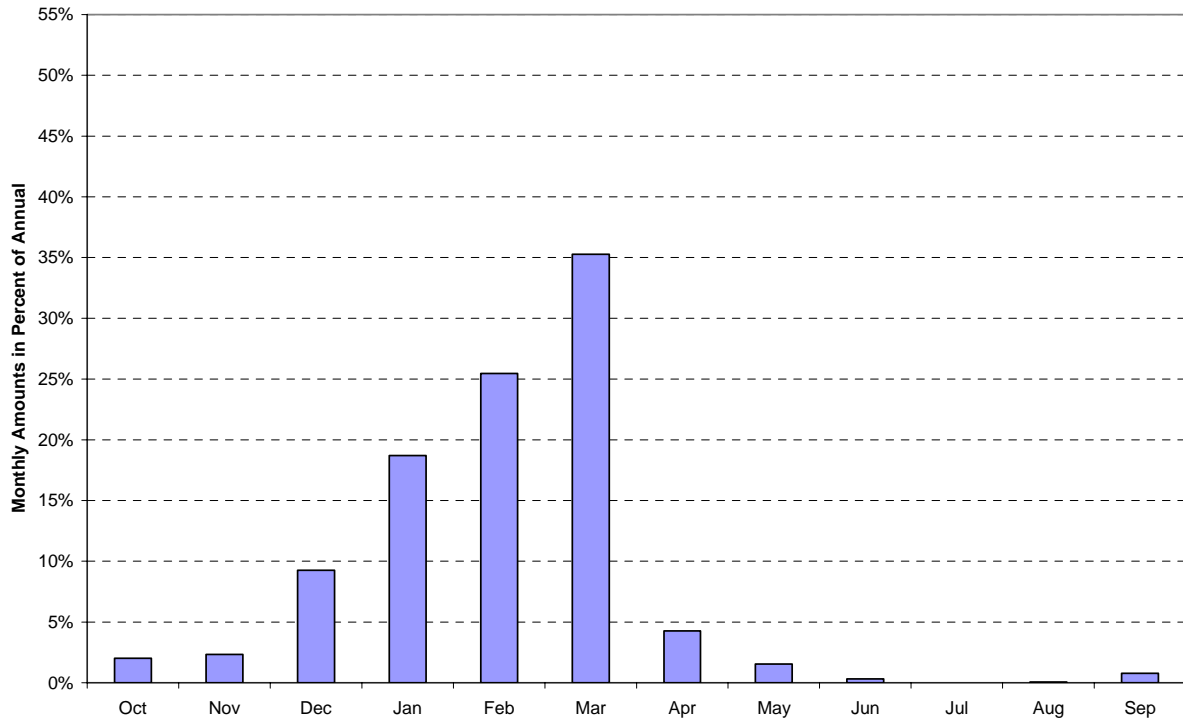

Average Monthly Distribution of SWP "Article 21" Water Under CalSim II - "Study 5"

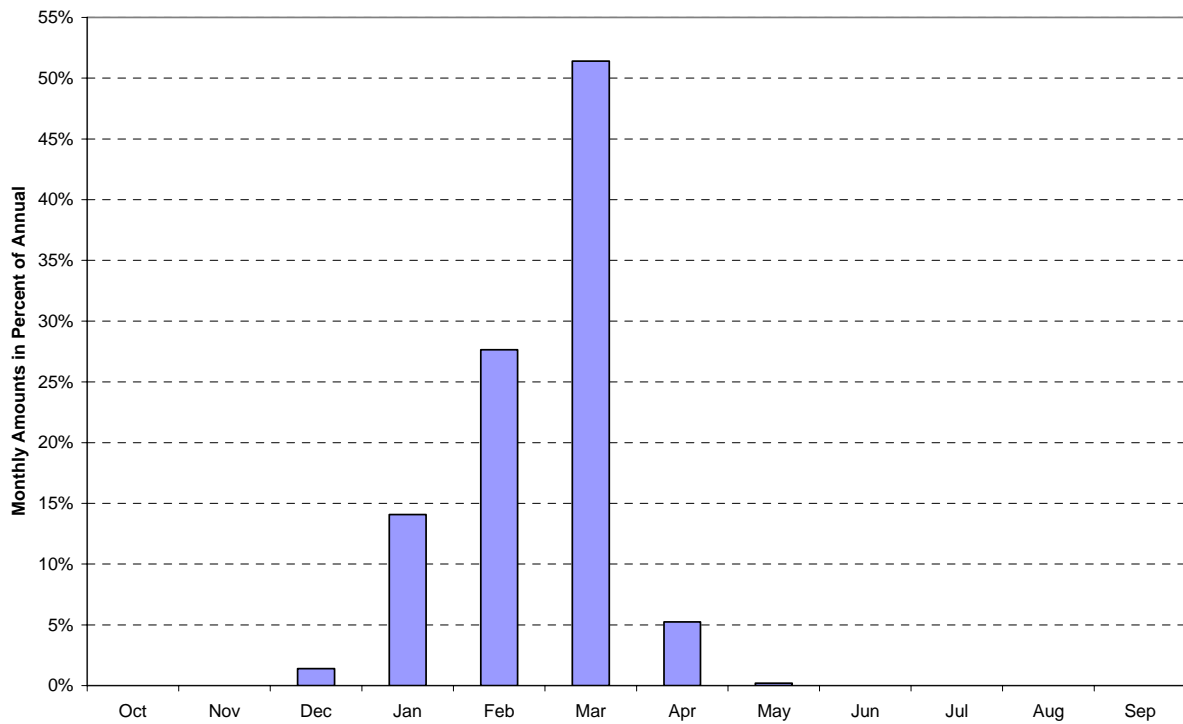

### **4.3.8 Summary**

Based on information presented hereinabove, it is estimated that the long-term average annual availability of surface water supplies to the Region is on the order of 0.7 million acre-feet. This estimate is based on availability at the source of supply and does not reflect consideration of any conveyance or absorptive capability limitations; rather, these limitations are considered in operations studies presented in Chapter 7.

Additionally, this estimate is based on the minimum “share” of unregulated SWP and CVP supplies and does not include third-party banking.

### **4.3.9 Groundwater**

As discussed above, owing to reduced water supply reliability, it is projected that less water will be available to the Region in the future as compared to the past. In addition to having less water available in the future, a portion of the water that is available will not be as “firm” as in the past and will require some form of regulation to be secured for the Region. It is likely that this regulation will have to come from and through water management programs developed cooperatively at the regional level. Just as in the past, it is reasonable to assume that groundwater will satisfy any additional shortages in surface water supplies, i.e., more groundwater will be used in the Region in the future than in the past. Accordingly, any reduction in surface water supplies can be expected to translate to a commensurate increase in the use of groundwater, assuming similar conditions of demand. While the magnitude of the water supply reduction is subject to some speculation, it is not unreasonable to think that the magnitude could be on the order of 100,000 acre-feet, on average over the long term. Given that water levels over the last 25 years have not evidenced an obvious long-term rise or decline, the expected loss of surface water supplies and the corresponding increase in the use of groundwater will induce a long-term decline in water levels. Historical water level fluctuations vis-à-vis historical water supplies provide some insight as to the potential magnitude of future water level declines. These data were presented previously and are reproduced on Figure 4-15.

### Regional Surface Water Diversions and Water Level Changes

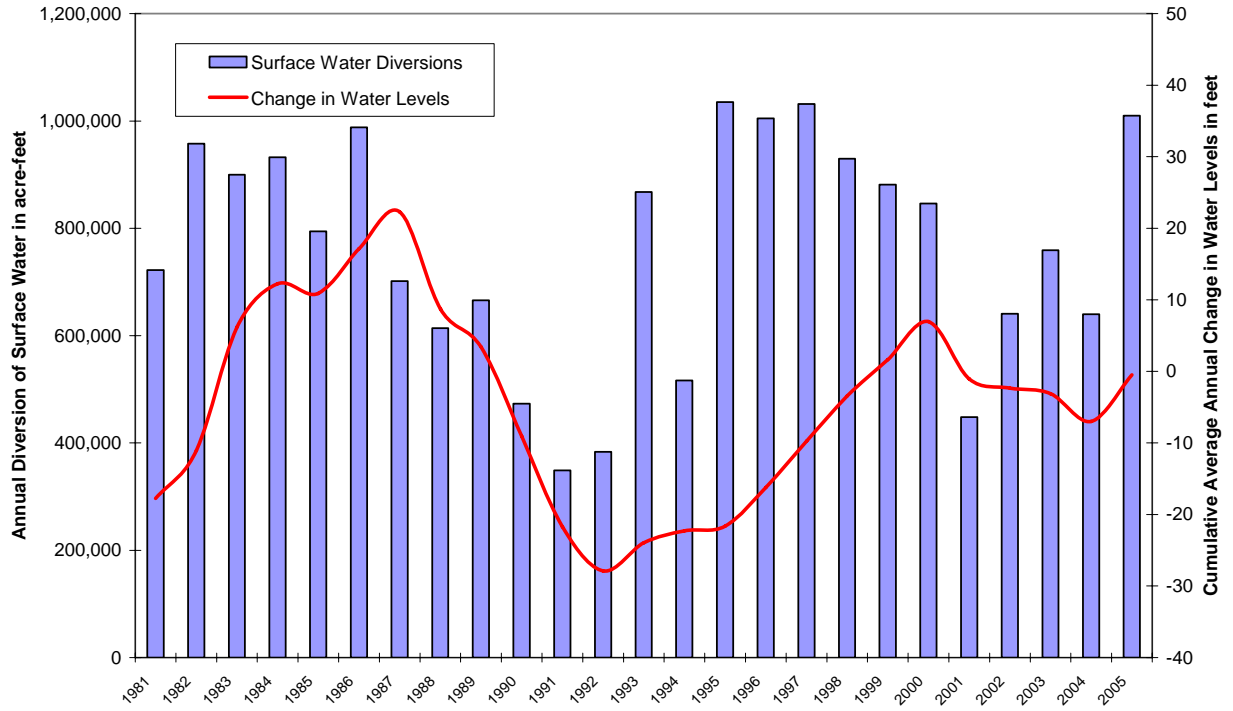

## **APPENDIX F2**

### **Chapter 5: Historical Water Use and Projected Water Demand**

## 5 Historical Water Use and Projected Water Demand

---

The fundamental questions which are addressed in this section are ...

- *What has been the historical “absorptive” capability?*
- *What is the future “absorptive” capability?*

*Absorptive capability* refers to the capability to divert and use surface water when available, where the *use* consists of deliveries to both irrigation and deliveries to spreading.

### 5.1 Overview of Water Demands

The present utilization of water supplies in the San Joaquin Valley portion of Kern County is predominantly for irrigated agriculture, which is also true for the Poso Creek RMA. As a generalization, all of the lands in the Poso Creek RMA are underlain by useable groundwater. Accordingly, to the extent that surface water supplies are inadequate to meet irrigation water requirements, groundwater is used to make up the shortfall. Further, all of the M&I use to date has relied on pumped groundwater. To the extent that surface water is available in excess of then current irrigation demands, and that water cannot be regulated in surface storage or otherwise rescheduled, then water is delivered to spreading for direct groundwater replenishment, up to the capacity of the spreading areas.

### 5.2 Historical Conditions

The historical use of water for irrigation, municipal and industrial, environmental and recreational, and groundwater replenishment is presented in the following paragraphs.

#### 5.2.1 Irrigated Agriculture

Presently, about 60 percent of the Poso Creek RMA is developed to permanent crops, primarily nuts and grapes. This was not always the case; in fact, permanent crops amounted to about 40 percent of the developed acreage 25 years ago. While cotton acreage has declined significantly over the last 25 years, cotton and alfalfa remain the single largest annual crops in terms of acreage. Figure 5-2 illustrates the areal distribution of annual and permanent crops in the Region, while Figure 5-1 illustrates the trends respecting annual and permanent crops, as well as the total irrigated acreage, over the last 25 years.

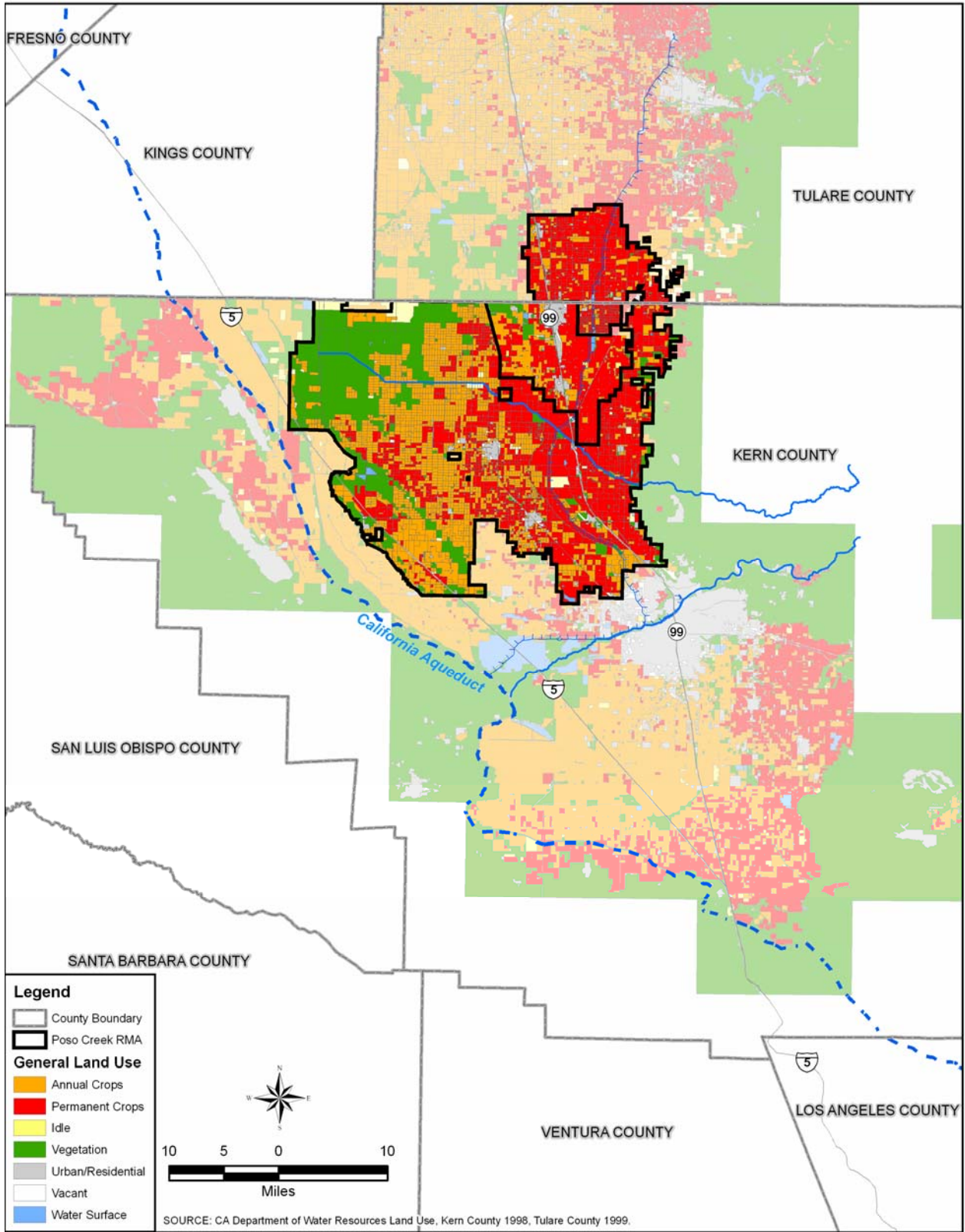



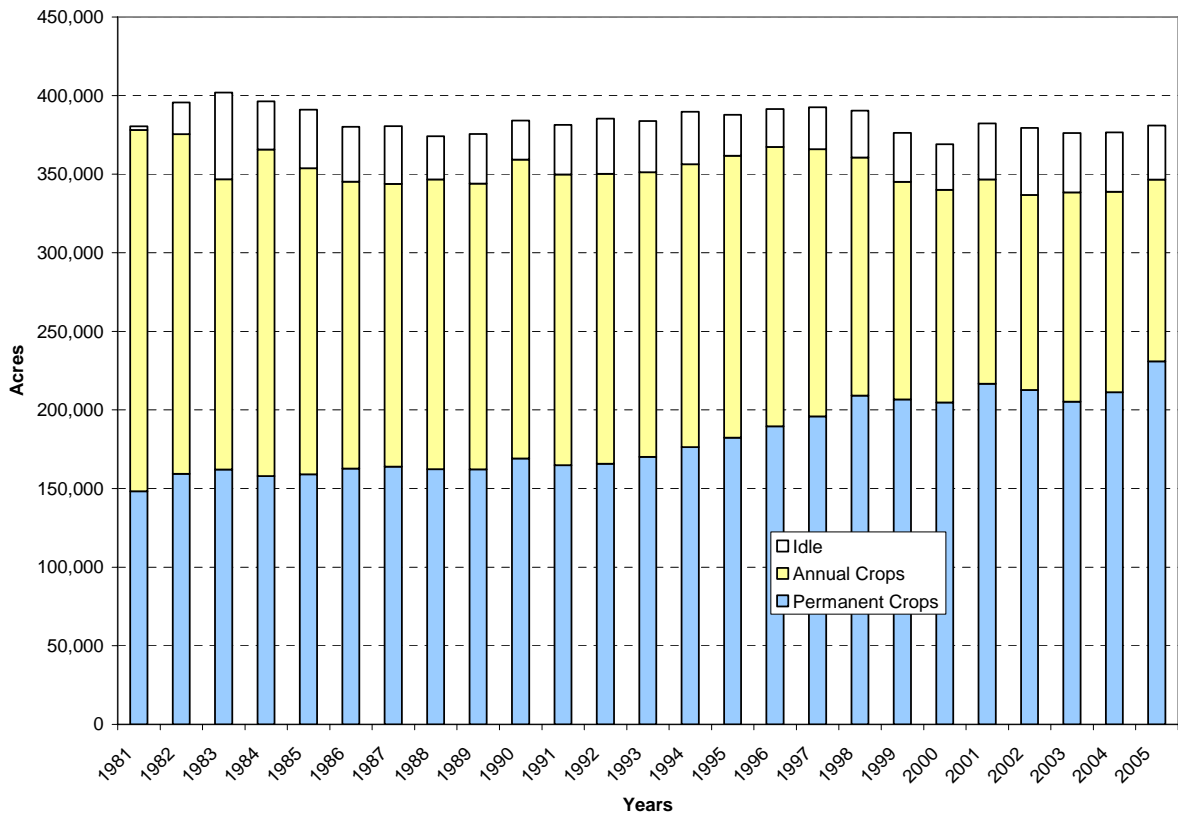

Table 5-1 presents the 2005 crop pattern.

**Table 5-1**

**2005 Crop Pattern  
for the Poso Creek RMA**

Nuts	32%
Vineyard	20%
Citrus	8%
Tree Fruit	2%
Subtotal Permanent Crops	62%
Alfalfa	10%
Cotton	9%
Grain	3%
Corn	3%
Vegetables (Misc.)	3%
Flowers	1%
Idle	9%
Subtotal Annual Crops	38%

The total irrigated acreage has generally ranged from 340,000 to 375,000, with an average of about 350,000 acres over the 1981 - 2005 period. While the majority of the irrigated acreage, is within the districts' surface water service areas (i.e., lands to which available surface water has been delivered), the remaining irrigated lands rely exclusively on pumped groundwater. Insofar as this planning study is concerned, it is important to understand how much water has been delivered to irrigation, because these data are reflective of the *existing* absorptive capability of irrigated agriculture in the Region. While the deliveries are a function of the available surface water supplies, they are also a function of the irrigation demand pattern and any facilities constraints that may exist with regard to conveyance and distribution. In particular, in those instances when available surface water supplies were not limiting, the deliveries only reflect the irrigation demand pattern and facilities constraints or, in other words, the *absorptive capability*. The annual deliveries to irrigation in the Poso Creek RMA are presented on Figure 5-3.

### Total Annual Deliveries to Irrigation within the Poso Creek RMA

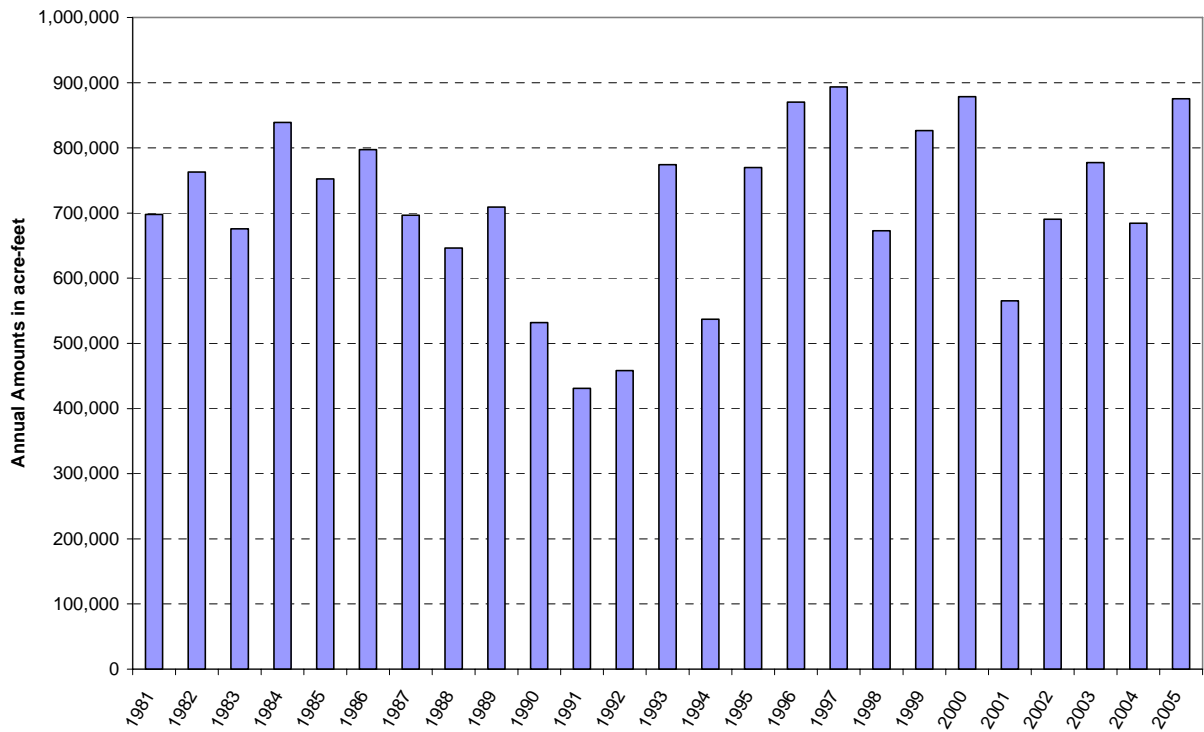

### **5.2.2 Municipal and Industrial**

To date, water for municipal and industrial purposes in the Region has been provided solely by pumped groundwater. These uses are concentrated in the communities of Shafter, Wasco, McFarland, and Delano. Currently, the combined population of these communities is on the order of 120,000, which represents an approximate doubling of the population between 1990 and 2006, or an average growth rate of about 5 percent per year. About 100,000 reside within the city limits, with the remainder in outlying areas. The *gross* use of pumped groundwater under 2006 conditions is estimated at about 40,000 acre-feet per year. While pumping by the principal water purveyors is measured and reported, other pumping is not; accordingly, the total remains an estimate. The return flows (primarily wastewater effluent) from urban uses are either recharged to the underground or applied for irrigation, and *net* water uses are estimated to be equal to the *gross* amount of pumped groundwater less wastewater effluent and any return flow from landscape watering.

### **5.2.3 Environmental and Recreational**

Environmental and recreational water uses within the Poso Creek RMA include the Kern National Wildlife Refuge and duck clubs as well as environmental uses that are incidental to other primary water uses.

*Kern National Wildlife Refuge* - The Kern National Wildlife Refuge (Refuge) is located in the northwestern portion of the Poso Creek RMA, largely within Semitropic. It covers almost 11,000 acres consisting of natural valley grasslands, a riparian corridor, and developed marsh. The Refuge lies just south of the Tulare Lake Bed, which once supported a lake that covered almost one-half million acres during flood years. As a remnant of this once expansive lake, KNWR provides wintering habitat for migrating birds, shorebirds, marsh and waterfowl, as well as upland species. About 6,400 acres are specifically managed for wetland purposes. In general, they will start wetting up the areas by sometime in August, and by February, they will begin to draw the water down. Regarding the drawdown, from 500 to 2,000 acre-feet is recycled by releasing the water from the Refuge and allowing it to be used for irrigation of crops on nearby lands.

When the Refuge was initially developed, its intended source of supply was pumped groundwater. However, it is understood that this was never an adequate supply; accordingly, the Refuge purchased surface water wherever it could do so to supplement whatever groundwater was produced. In the 1990s, with the passage of the Central Valley Project Improvement Act (CVPIA), the Refuge was given access to federal water up to 25,000 acre-feet annually; however, the Refuge has yet to receive that much water. Over the last 25 years, the Refuge has relied almost exclusively on surface water, with groundwater use being negligible during that period. Annual deliveries to the Refuge are shown on Figure 5-4, which highlights the increase in deliveries in the 1990s, as a result of CVPIA.

Surface Water Deliveries to Kern National Wildlife Refuge

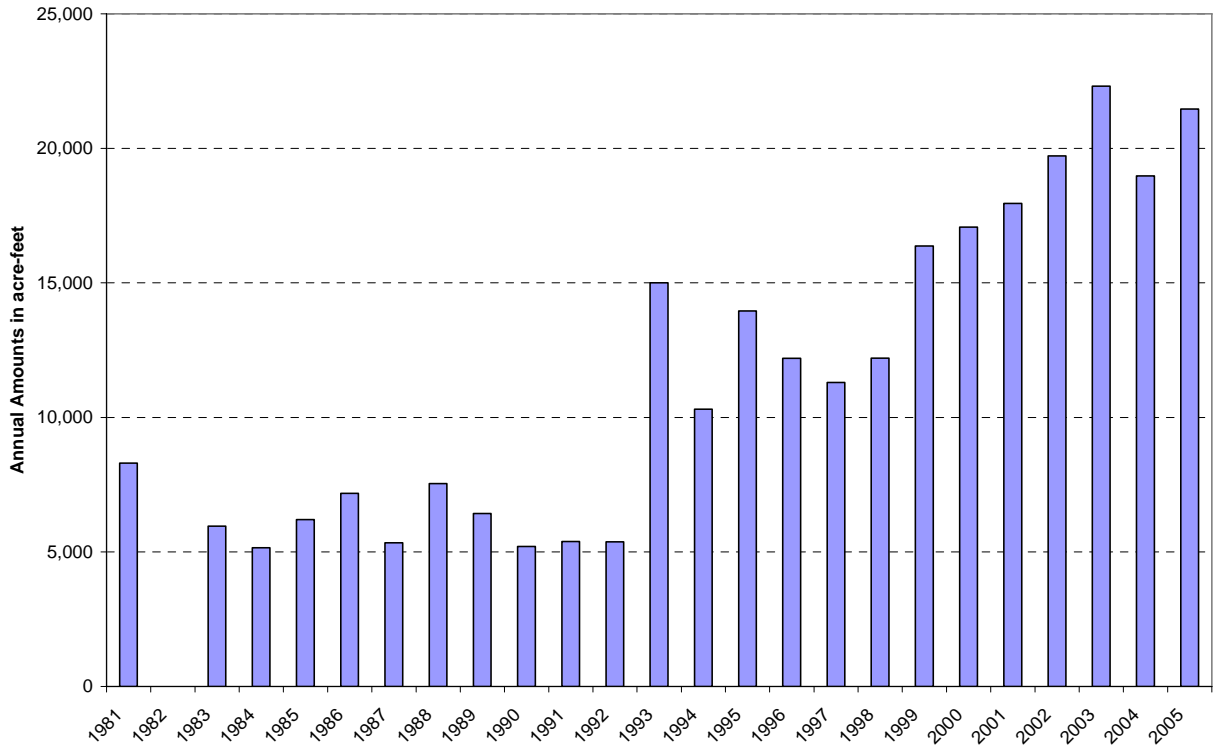

Duck Clubs - There are roughly 2,000 – 3,000 acres of private duck club ponds which are operated specifically for attracting waterfowl, and most of these are located in Semitropic. The primary water source for these ponds is groundwater. These duck club ponds apply an estimated 5,000 – 10,000 acre-feet annually. Semitropic has tracked land use in its area for many years, and the acreage devoted to duck ponds has not fluctuated significantly.

Groundwater Recharge Ponds - Groundwater recharge facilities generate incidental environmental benefits. When recharge ponds are full of water, they attract numerous waterfowl. These typically shallow ponds are not unlike the ponds which are maintained specifically for waterfowl benefits at the KNWR. More than 2,000 acres of spreading ponds are located in the Poso Creek RMA, specifically in North Kern and Cawelo, with individual sites ranging from about 50 acres to about 600 acres. While North Kern has spread a considerable amount of water in *wet* years, they have spread at least some water in almost all years.

#### **5.2.4 Groundwater Replenishment**

Groundwater is replenished through both *direct* and *indirect* means, where *direct* refers to water spreading in constructed ponds or natural channels, and *indirect* refers to surface water deliveries in lieu of pumping groundwater. The latter is often referred to as *in-lieu recharge* and is included in the deliveries to irrigation which is addressed in Section 5.2.1. Respecting direct recharge, North Kern has been operating more than 1,500 acres of spreading ponds to directly replenish the underlying groundwater for over 50 years. In fact, North Kern pioneered the construction and operation of large-scale spreading works in the southern San Joaquin Valley. More recently, Cawelo constructed more than 500 acres of ponds; however, these ponds do not have an operational history. The channel of Poso Creek has also been an important area for intentional recharge.

North Kern constructed its ponds in the 1950s to regulate its highly variable Kern River supply, which it has been doing successfully since that time. In particular, North Kern has recharged up to about 25,000 acre-feet per month and up to about 240,000 acre-feet in a single year, utilizing both its ponds and the channel of Poso Creek. Over the last 25 years (1981-2005), North Kern has recharged a total of more than 1.5 million acre-feet. Figure 5-5 illustrates the annual fluctuations of intentional recharge over this same period.

In addition to groundwater replenishment within the Region, direct recharge has also taken place outside of the Region for the same purpose, i.e., regulation of available surface water supplies. Specifically, Semitropic has caused water to be delivered to the Kern Water Bank from time to time. The Kern Water Bank is located on the Kern fan, immediately south of the Poso Creek RMA. Semitropic’s deliveries to the Kern Water Bank commenced in 1995.

North Kern Deliveries to Spreading

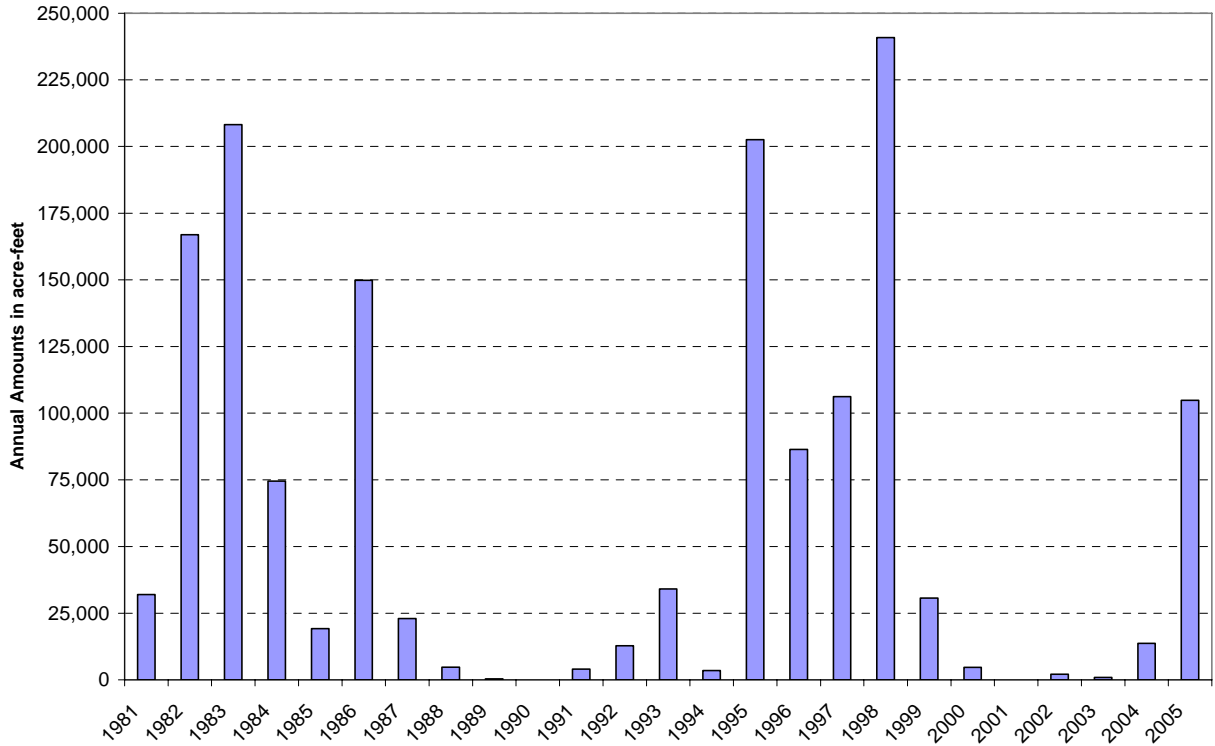

### 5.3 Projected Conditions

Total water requirements for irrigation, municipal and industrial, and environmental and recreation within the Region are expected to change little from that of present conditions, inasmuch as the Region is, for practical purposes, fully developed. While significant population growth has occurred over the last 25 years and is expected to continue, it has typically been accommodated by converting agricultural land to urban uses. While there can be differences in water use between an acre of irrigated farmland and an acre developed to urban uses, it is not unreasonable, for regional planning purposes, to assume that the total water use is comparable.

#### 5.3.1 Irrigated Agriculture

Since, as noted in Section 5.2.1, there have been changes in cropping patterns over the last 25 years, water deliveries in the more recent years are considered to be the best measure of projected conditions. Further, in terms of absorptive capability, it is appropriate to give more weight to years where the available surface water supply was not the most significant limiting factor. Accordingly, inspection of records of historical deliveries yielded the following annual absorptive capabilities for irrigation in the Region, which are considered representative of future conditions for purposes of this planning effort.

**Table 5-2**

**Annual Absorptive Capabilities  
for Irrigation in the Region**

Cawelo	75,000 af
Delano-Earlimart	135,000
Kern-Tulare & Rag Gulch	45,000
North Kern	140,000
Semitropic	310,000
Shafter-Wasco	70,000
Southern San Joaquin	125,000
	<hr/> 900,000 af

These annual amounts have been delivered on an irrigation demand schedule throughout the year. Based on monthly delivery records for recent years, a *typical* monthly pattern was developed for each district within the Region. These patterns are illustrated on Figure 5-6. The most notable difference occurs early in the year and is related to the pre-irrigation of cotton. In particular, those districts with measurable cotton acreage show a relatively greater delivery early in the year.



Monthly Irrigation Delivery Patterns

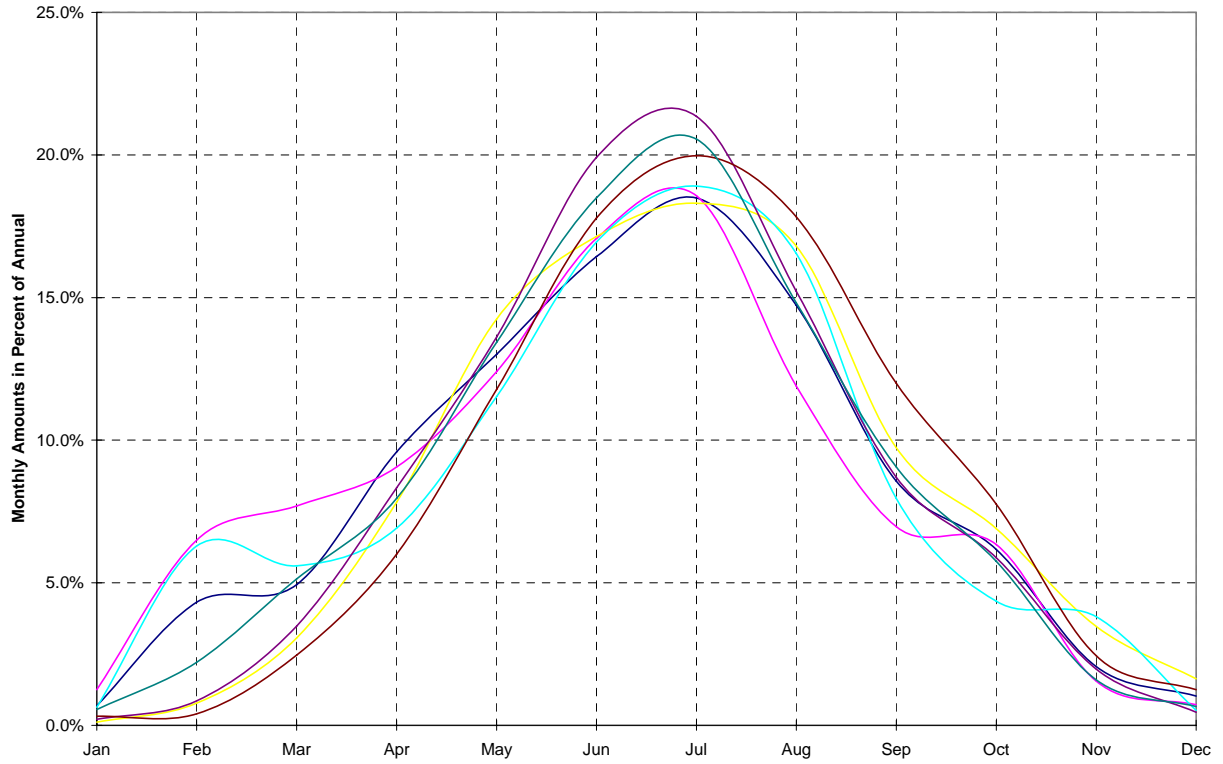

### **5.3.2 Municipal and Industrial**

Recall (from Section 5.2.2) that the observed population growth rate for the Region was about 5 percent annually since 1990. Assuming that this rate continues, the population of the Region could double in the next 15 years. Similarly, gross water use can be expected to double, from the current estimate of 40,000 acre-feet to 80,000 acre-feet, absent additional conservation measures. The monthly pattern of M&I use is illustrated on Figure 5-7 along with the average monthly delivery pattern for agriculture for the Region. While the patterns are generally similar in shape, the overall peak use is relatively less for M&I than for irrigated agriculture.

### **5.3.3 Environmental and Recreational**

Recall that environmental and recreational water uses include the Kern National Wildlife Refuge and duck clubs.

Kern National Wildlife Refuge - While surface water deliveries to the Refuge have averaged about 11,000 acre-feet per year over the last 25 years, annual deliveries have been building up since the mid 1990s, when the Refuge received an allocation of federal water under CVPIA. Accordingly, the more recent deliveries are considered to be more reflective of future conditions, i.e., on the order of 20,000 to 25,000 acre-feet per year. However, unlike irrigated agriculture in the Region, to the extent that surface water supplies are *short*, it is not likely, at least under present conditions, that the shortage would be made up by pumped groundwater. Accordingly, there is not the same relationship between surface water deliveries and groundwater levels that exists with irrigated agriculture.

Duck Clubs - As noted in Section 5.3.3, there have not been appreciable changes in the acreage devoted to duck ponds for many years. Accordingly, it is not unreasonable to assume that about this same acreage would continue to be used for this purpose for the foreseeable future.

Typical Monthly Delivery Patterns for M&I and Agriculture

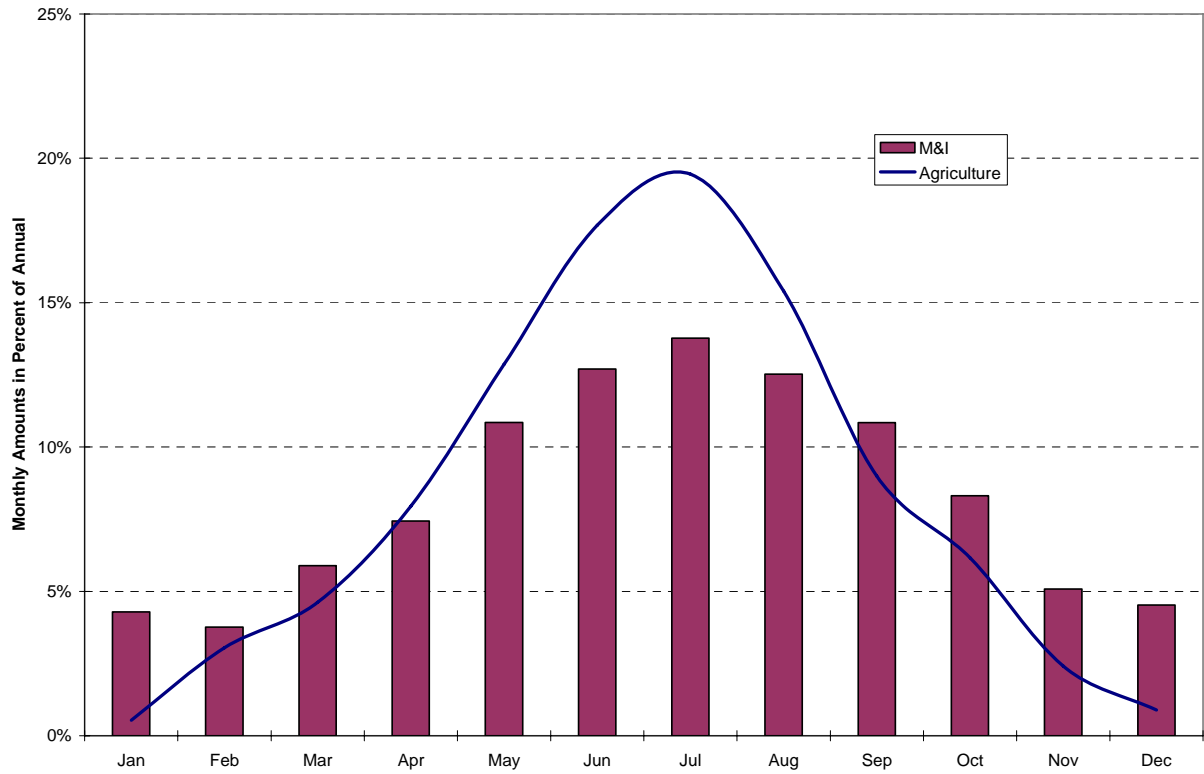

### **5.3.4 Applied Water**

Based on information presented hereinabove, it is estimated that the long-term average annual applied water demand for the Region is on the order of 1.3 million acre-feet. This includes consideration of agricultural (at 3.5 acre-feet per acre), municipal and industrial, and environmental uses.

### **5.3.5 Groundwater Replenishment**

Recall from the discussion of historical conditions, this discussion is limited to direct groundwater replenishment through spreading. To the extent that surface water supplies available to the Region become less reliable in the future, which is the conclusion which is reached in Section 4.2, there will be an increased demand for local regulation through direct recharge to groundwater storage. As noted in Section 5.2.4, Cawelo only recently completed construction of more than 500 acres of ponds; however, these ponds do not have an operational history. In the absence of an operational history, it is not unreasonable to think that Cawelo's spreading ponds will perform in a manner similar to those located in North Kern, inasmuch as they are proximate to two of North Kern's spreading works sites. On this basis, it is estimated that the spreading ponds in Cawelo have added between 7,000 and 8,000 acre-feet per month of spreading capacity in the Region. Collectively, North Kern and Cawelo provide the capability to spread on the order of 32,000 to 33,000 acre-feet per month.

In addition, Semitropic is constructing its first spreading ponds; however, owing to different subsurface conditions, the long-term spreading capacity remains speculative. However, as experience is gained with these yet-to-be completed ponds, they will further increase the Region's absorptive capability with respect to direct recharge.

Finally, recall that water has been recharged and stored on the Kern Fan, located to the south of the Poso Creek RMA, from time to time. In particular, this has involved two of the fan's direct recharge projects; the Kern Water Bank, and the Pioneer Project. Semitropic is a participant in the Kern Water Bank and both Semitropic and Cawelo are participants in the Pioneer Project.

## **APPENDIX F3**

### **Chapter 7: Water Supply Operations Studies**

## 7 Water Supply Operations Studies

---

The fundamental questions which are addressed in this section are ...

- *How much of the surface water supplies which are projected to be available in the future can be “absorbed” under present conditions?*
- *How much of the surface water supplies which are projected to be available in the future cannot be “absorbed” under present conditions?*

### 7.1 Present Conditions

For purposes of this report, *present conditions* refer to the absorptive capability under the current physical and institutional setting. In this section, the surface water supplies which are projected to be available to the Region in the future (reference Section 4.3) are compared with the absorptive capacity under present conditions in order to answer the above-stated questions.

#### 7.1.1 Approach

The hydrologic period extending from 1922 through 1994 was used as the period over which projected surface water supplies were evaluated against the absorptive capacity. Ultimately, the amount of surface water that can be absorbed (i.e., diverted and used) within a given district is a function of the available supply, conveyance capacity from the source of supply to the district, and internal absorptive capacity. The evaluation was conducted on a district-by-district basis, considered only the contract supplies available to that district, and followed these generalized steps:

- (1) On a monthly basis, consider the extent to which unregulated supplies available to a given district satisfy the irrigation absorptive capability of that district.
- (2) On a monthly basis, consider the extent to which any remaining unregulated supplies can satisfy spreading absorptive capability (if any).
- (3) On an annual basis, consider the extent to which regulated supplies available to a given district satisfy the remaining irrigation absorptive capability.

As a result of applying these tests, any remaining irrigation absorptive capacity, spreading absorptive capacity, regulated supplies, and unregulated supplies were quantified for each

---

district. In other words, absent other arrangements, these results reflect the best a given district could do with its own supplies and absorptive capacity.

### **7.1.2 Available Supplies**

The surface water supplies projected to be available in the future were addressed in Section 4.3. Recall that these data reflect the availability at the source of supply and do not reflect conveyance constraints from the source of supply to a given district. Further, while the regulated supplies are district specific, the unregulated supplies are not. In particular, assumptions must be made with respect to how much of the system-wide unregulated supplies can be expected to be available to a given district. On the SWP, this refers to *Article 21 water*, and on the CVP-Friant side, this refers to *Other Friant water*. Certain assumptions in this regard were made and noted in Sections 4.3.5 and 4.3.7. These assumptions are believed to be conservative, i.e., if anything, the available supplies have been underestimated. The extent to which the monthly availability of *Article 21 water* and *Other Friant water* overlap or not is illustrated on Figure 7-1. It is noted that the second chart, which is in acre-feet, reflects the system-wide availability. Figure 7-2 illustrates the annual frequency of availability for each month, for each of these two sources of supply.

### **7.1.3 Conveyance Capacity**

The two main conveyance features are the California Aqueduct and the Friant-Kern Canal. For purposes of this study, conveyance constraints were only considered with respect to the unregulated surface supplies.

*California Aqueduct* - The projections of *Article 21 water* include consideration of pumping capacity at the Banks Pumping Plant; accordingly, no further constraints were considered in conveying the water south in the California Aqueduct.

*Friant-Kern Canal* - The data respecting *Other Friant water* reflect the system-wide availability of this type of water at Friant Dam, i.e., the data do not reflect any conveyance constraints in the Friant-Kern Canal. Based on the knowledge and experience of the CVP-Friant contractors in the Poso Creek RMG, it was assumed that there would not be any capacity to convey *Other Friant water* to the Region during the months of May through August. This is a significant assumption inasmuch as the projections suggest that, depending on the hydrology of a given year, availability of this type of water can include the months of May, June, and July, or about one-third of the average annual availability. Further, given that the recent San Joaquin River settlement has yet to be implemented, the rules which will govern the sharing of Friant-Kern Canal capacity to move this water are uncertain at this time. With regard to the remaining months, September through April, it was assumed that conveyance capacity would not be a constraint. Sensitivity to this latter assumption was also tested.

**Average Monthly Distribution of "Other" Friant Water Under Post-Settlement Conditions and SWP "Article 21" Water Under "Study 4"**

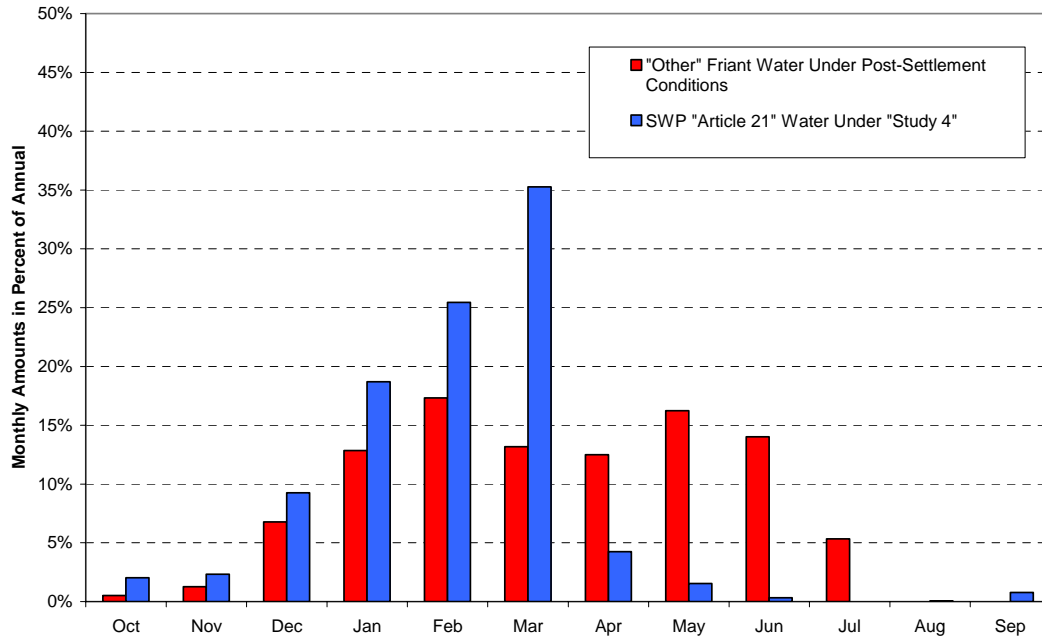

**Average Monthly Distribution of "Other" Friant Water Under Post-Settlement Conditions and SWP "Article 21" Water Under "Study 4"**

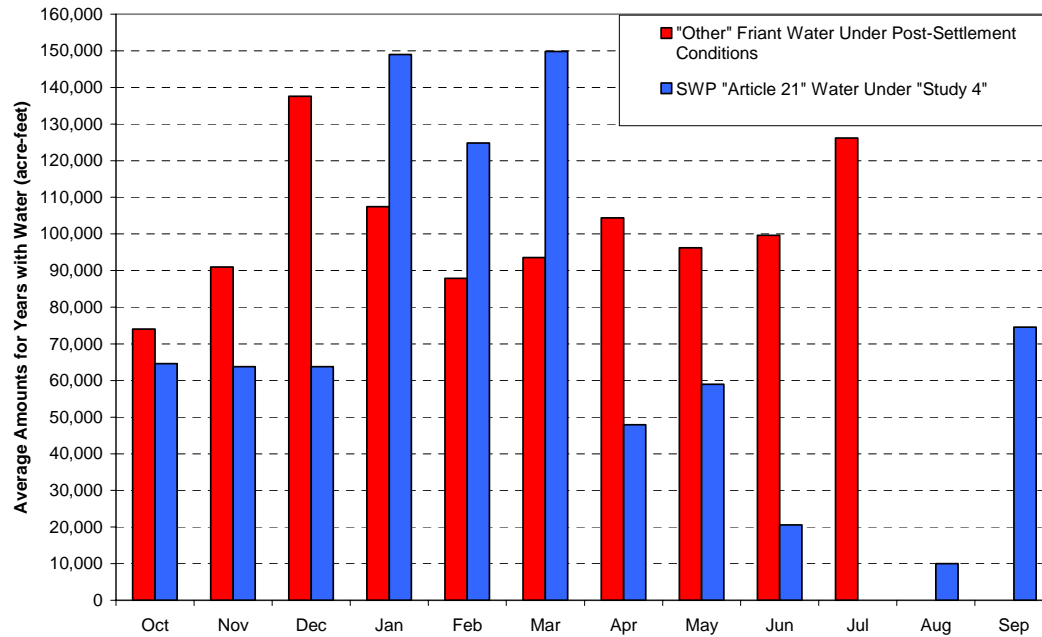



**Frequency of Years with "Other" Friant Water Under Post-Settlement Conditions  
or SWP "Article 21" Water Under "Study 4"**

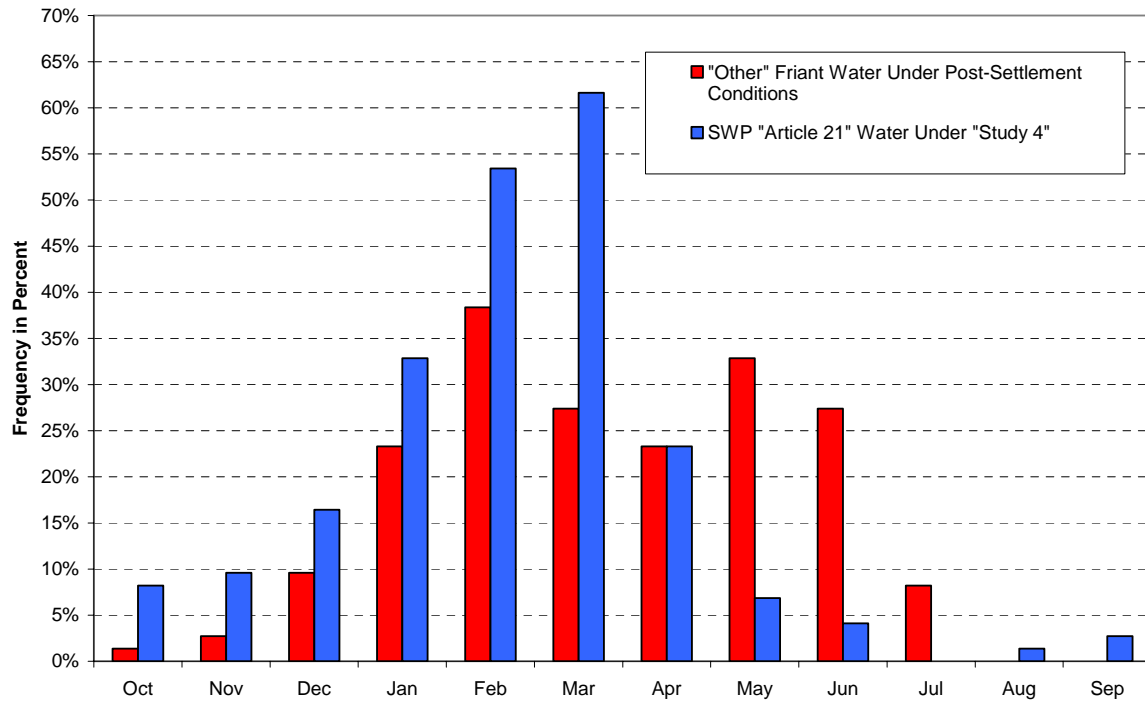

**7.1.4 Absorptive Capacity**

There are two components to absorptive capacity; there is an irrigation component and a spreading component. While the irrigation component is common to all districts in the Region, the spreading component is not. In particular, recall that North Kern and Cawelo are the only districts with significant spreading capability within the Region. Both of these components were addressed in Section 5.3. In particular, the spreading absorptive capacity for North Kern and Cawelo was taken at 20,000 and 2,500 acre-feet per month, respectively. These were reduced from the maximum amounts to be conservative and, in the case of Cawelo, to reflect the fact that there is no history of operations upon which to assess unused capacity, as there was in the case of North Kern. The annual irrigation absorptive capacities are summarized following in Table 7-1.

**Table 7-1**

**Annual Absorptive Capabilities  
for Irrigation in the Region**

Cawelo	75,000	af
Delano-Earlimart	135,000	
Kern-Tulare & Rag Gulch	45,000	
North Kern	140,000	
Semitropic	310,000	
Shafter-Wasco	70,000	
Southern San Joaquin	125,000	
	<u>900,000</u>	af

The total absorptive capability for the Region is illustrated on a monthly basis for both irrigation and spreading on Figure 7-3. The bottom chart on Figure 7-3 provided an illustrative comparison of the irrigation absorptive capability under present conditions to the maximum potential capability, where the maximum assures that conveyance and distribution facilities existed to serve every irrigated acre in the Region.

**7.1.5 Projected Use of Available Surface Water Supplies**

With regard to imported SWP and CVP-Friant water supplies, the projected average annual use within the Poso Creek Region was estimated to be reduced by about 70,000 acre-feet as compared to historical deliveries for the 1981-2005 period, with about one-half of the amount attributable to each of the two sources. In addition, it was assumed that the yield of the contracts for Kern River water with the City of Bakersfield would be reduced by one-half, or about 34,000 acre-feet. Accordingly, the total reduction in use of these sources of supply was estimated at about 105,000 acre-feet, which represents a 14 percent reduction in the total surface supplies to the Region.

**Absorptive Capability for the Poso Creek RMA Under Present Conditions**

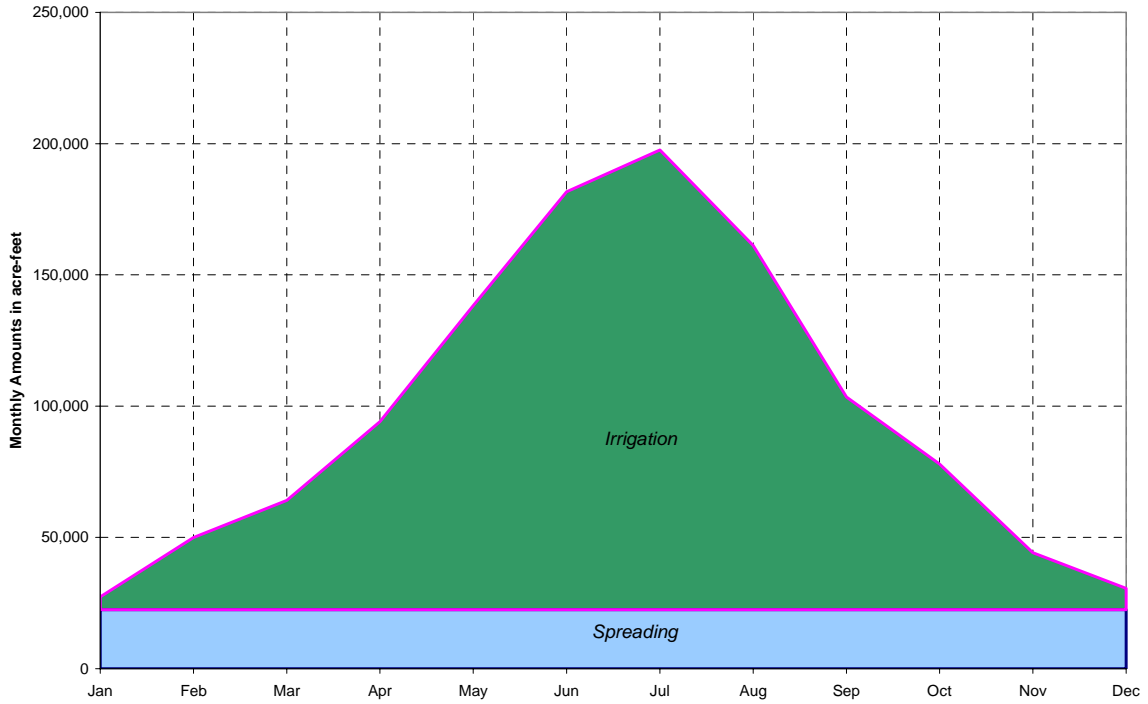

**Irrigation Absorptive Capability for the Poso Creek RMA Under Present Conditions Compared with the Maximum Potential Capability**

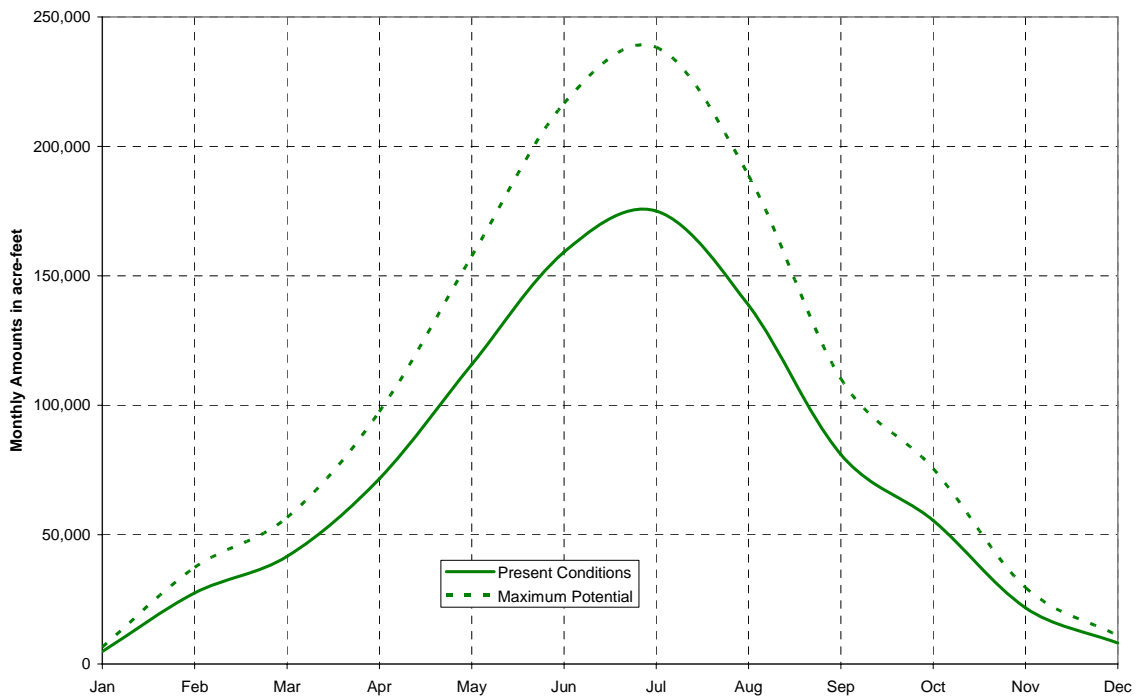

### **7.1.6 Unused Surface Water Supplies**

After consideration of the available supplies, conveyance capacity, and absorptive capacity on a district-by-district basis, a portion of the available surface water supplies remains unused from time to time. The average annual amount that was available but remained unused was estimated at about 31,000 acre-feet over the 1922-1994 hydrologic period. This average principally consists of CVP-Friant water; about 8,000 acre-feet of *Other* Friant water that was constrained by conveyance in the Friant-Kern Canal; about 7,000 acre-feet of *Other* Friant water that was beyond the present absorptive capability; and about 14,000 acre-feet of *Class 1* and *Class 2* water that was also beyond the present absorptive capability. This water typically occurs in the wetter years.

### **7.1.7 Unused Absorptive Capacity**

After considering the available surface water supplies on a district-by-district basis, there is unused absorptive capacity from time to time, including both irrigation and spreading. In particular, there is unused capacity at times when there are unused surface water supplies within the Region.

### **7.1.8 Sensitivity**

These results are sensitive to a number of criteria and assumptions. One of the larger factors is the amount of unscheduled state and federal water that will be available to the Region, i.e., SWP *Article 21* water and CVP-Friant *Other* water. First, there is the estimate of the system-wide availability; then, the estimate of the amount available specifically to districts within the Poso Creek RMA. With regard to the latter, it is believed that the assumptions which are reflected in the results reported in Section 7.2 represent the minimum or worst-case bookend. In other words, it is believed to be likely that more water will be available to the RMA, owing to the inability of others (who have a right to a share of the water) to put the water to use when it is available. While the amount is speculative, the evaluation was repeated under the assumption that the amount of CVP-Friant *Other* water was doubled. This had little effect on the amount of water delivered; however, it increased the undelivered amount from about 21,000 acre-feet to 37,000 acre-feet per year.

### **7.1.9 Summary and Conclusions**

When considered on a district-by-district basis, the surface water supplies available to the Poso Creek RMA are not usable in their entirety because of the timing and magnitude of the occurrence of water quantities in excess of absorptive capacity. Most of the unused supply is CVP-Friant water; *Class 1* and *Class 2*, as well as *Other*, which typically occur in the wetter years. Accordingly, from a regional water management perspective, most important is the occurrence of unused absorptive capacity within the Region coincident with the occurrence of unused surface water supplies available to the Region. As a generalization, there is unused irrigation absorptive capacity in Semitropic and Cawelo at times when there are

unused regulated supplies (primarily CVP-Friant *Class 1* and *Class 2* water). Also as a generalization, there is unused spreading absorptive capacity in North Kern and/or Cawelo at times when there are unused unregulated supplies (primarily CVP-Friant *Other* water). Finally, there is not enough undelivered water to offset more than about one-third of the indicated reduction in deliveries in the best case.

## 7.2 Future Conditions

Similar to the evaluation of present conditions (Section 7.1), the surface water supplies which are projected to be available to the Region in the future are again compared with the absorptive capacity; however, certain changes are reflected in the institutional and/or physical setting. In particular, there is the potential for increasing the Region’s absorption of available surface water supplies through 1) local agreements and institutional approvals respecting movement of water between districts within the RMA, 2) conveyance improvements to link the source of supply to the location of the unused absorptive capacity, and 3) development of new absorptive capacity. It is noted that the comparison of results between present and future conditions was based on the assumed increase in the availability of CVP-Friant *Other* water that was considered in Section 7.1. In other words, each scenario considers how much of the undelivered amount (37,000 acre-feet per year on average) could potentially be absorbed within the Region.

### 7.2.1 Scenario A

Under this scenario, certain changes to the present institutional setting are considered. In particular, it is assumed that SWP water and CVP water can be delivered anywhere within the Region. This scenario is based on the present physical setting, i.e., no facilities improvements are reflected. It is estimated that an additional 16,000 acre-feet per year on average could be used in the Region, which would reduce the undelivered amount to about 30,000 acre-feet per year on average. Development of the 16,000 acre-feet is summarized below:

- 2,000 af ..... Class 1 and Class 2 deliveries to North Kern and Cawelo for irrigation.
- 5,000 af ..... Class 1 and Class 2 deliveries to Semitropic by exchange with Cawelo.
- 2,000 af ..... Semitropic *Article 21* water to North Kern and Cawelo for spreading.
- 7,000 af ..... *Other* Friant water to North Kern and Cawelo for spreading.

### 7.2.2 Scenario B

Under this scenario, certain conveyance improvements to link the source of supply to the location of the unused absorptive capacity are considered, along with the institutional

changes contemplated in Scenario A. In particular, it is assumed that the capacity of North Kern's turnout from the Friant-Kern Canal is increased from 200 cfs to 400 cfs. It is estimated that this would increase the delivery of *Other* Friant water to spreading in North Kern and Cawelo by about 2,000 acre-feet as compared to Scenario A. However, there remains about 10,000 acre-feet per year (on average) of undelivered *Class 1* and *Class 2* water, which could be released into Poso Creek for delivery to Semitropic and/or could be delivered to unused spreading capacity in North Kern and Cawelo. It is noted that this average is the result of water occurring in about one to two years out of ten, i.e., they are the wettest years. Since the *Class 1* and *Class 2* supplies are regulated, it is reasonable to expect that some portion of this water could be absorbed in the Region. It has been very roughly estimated that on the order of one-half of the 10,000 acre-feet could be absorbed in unused spreading capacity. Accordingly, the additional diversion, as compared to present conditions, would be about 18,000 acre-feet per year plus that portion of the remaining 10,000 acre-feet of *Class 1* and *Class 2* water, for a range of 23,000 acre-feet up to a maximum of 28,000 acre-feet per year on average.

## **APPENDIX G**

### **Project Definition and Characterization Form (PDCF) Submission Form<sup>1</sup> for Project/Program inclusion in the Integrated Regional Water Management (IRWM) Plan**

---

<sup>1</sup> Appendix includes PDCF as of June 2019. Contact the IRWM Lead Agency for most up-to-date PDCF form, may be different from the form included in this Appendix.



## **Project Definition and Characterization Form (PDCF)**

### *Project and Program Submission Form for the Poso Creek Integrated Regional Water Management Plan (IRWMP) 2019 Update*

Please mail completed form to the following address, or bring complete form to one of the regular IRWM meetings (as scheduled);

Poso Creek RWMG  
c/o Semitropic WSD  
1101 Central Avenue  
Wasco, CA 93280

For questions or concerns regarding the form, please contact:

Paul Oshel, Poso Creek IRWM Representative  
(661-758-5113)

### **1.0 Background Information**

**Please provide the following information regarding the project/program sponsor.**

Implementing Agency/ Organization / Individual:

---

Agency / Organization / Individual Address:

---

---

Possible Partnering Agencies:

---

---

Contact Person Name:

---

Title:

---

Telephone:

Fax:

---

---

Email:

---



**Please provide the following information regarding the proposed project or program.  
Check the box that applies:**

Project (e.g. structural enhancements,  
infrastructure upgrades, etc.)

Program (e.g. policy updates,  
management suggestions, etc.)

Project or Program Name:

---

---

Project or Program Cooperating Agency/Organization(s), including potential funding sources  
(e.g., Kern County Water Agency, DWR/USBR Funding, environmental or agricultural groups):

---

---

---

---

---

Project Status (e.g., new, ongoing, expansion, new phase with brief description):

---

---

---

**Please provide the following information regarding the location of the project, including  
the name of the District(s) or Agency which has jurisdiction over the project area. If the  
proposal is for a non-structural program, please state the District(s) or Agency where the  
program will be implemented.**

Districts or Agencies (i.e., location corresponding to District or Agency service areas):

---

---

---

---

Description of Proposed Location:

---

---

---

---

---

Latitude (if available):

---

Longitude (if available):

---

## **2.0 Project/Program Description**

**Please provide a general description of the proposed project or program, including an assessment of the potential impacts and benefits of implementing the project or program. This section should provide information regarding the project concept, general project information, and readiness to proceed.**

If applicable, please list the existing water conveyance infrastructure associated with the proposed project or program:

---

---

---

---

Source of assumed increased supply or demand reduction (check all that apply):

- |  |   |   |
|--|---|---|
| <input type="checkbox"/> Surface Water (Supply Management) | <input type="checkbox"/> Groundwater Recharge (Storage/Banking) | <input type="checkbox"/> Conveyance/Delivery Efficiency |
| <input type="checkbox"/> Groundwater (Treatment)           | <input type="checkbox"/> Conservation/Water Use Efficiency      | <input type="checkbox"/> Conjunctive-Use Management     |
| <input type="checkbox"/> Transfer/Exchange                 | <input type="checkbox"/> Other (describe): _____                |   |

If applicable, please list any available documents which contain information specific to the proposed project or program (include conceptual plans, permits, drawings, and any technical documents):

---

---

---

---

For projects or programs ready for construction or implementation, briefly describe the readiness-to proceed:

---

---

---

---

---

Does the project have the potential to reduce dependence on water originating from the Sacramento-San Joaquin River Delta?

- Yes                       No                       Not Sure

Does the project address any known environmental justice issues?

- Yes                       No                       Not Sure

Is the project located within or adjacent to an *economically-disadvantaged community* (DAC)?

Yes  No  Not Sure

Does the project include DAC participation, or involvement from the DAC Representative or Work Group?

Yes  No  Not Sure

If yes, please identify the group, organization, or requested services of the DAC Representative or Work Group:

---

---

---

---

Please describe any benefits that the proposed project or program may have towards preparing the region for the presumed effects of climate change, see Section 13.0 of the 2014 IRWM Plan:

---

---

---

---

---



## **Project Definition and Characterization Form (PDCF)**

*Project and Program Submission Form for the Poso Creek  
Integrated Regional Water Management Plan (IRWMP) 2019 Update*

Please mail completed form to the following address, or bring complete form to one of the regular IRWM meetings (as scheduled);

Poso Creek RWMG  
c/o Semitropic WSD  
1101 Central Avenue  
Wasco, CA 93280

For questions or concerns regarding the form, please contact:

Paul Oshel, Poso Creek IRWM Representative  
(661-758-5113)

### **1.0 Background Information**

**Please provide the following information regarding the project/program sponsor.**

Implementing Agency/ Organization / Individual:

---

Agency / Organization / Individual Address:

---

---

Possible Partnering Agencies:

---

---

Contact Person Name:

---

Title:

---

Telephone:

Fax:

---

---

Email:

---



## **Project Definition and Characterization Form (PDCF)**

*Project and Program Submission Form for the Poso Creek  
Integrated Regional Water Management Plan (IRWMP) 2019 Update*

Please mail completed form to the following address, or bring complete form to one of the regular IRWM meetings (as scheduled);

Poso Creek RWMG  
c/o Semitropic WSD  
1101 Central Avenue  
Wasco, CA 93280

For questions or concerns regarding the form, please contact:

Paul Oshel, Poso Creek IRWM Representative  
(661-758-5113)

### **1.0 Background Information**

**Please provide the following information regarding the project/program sponsor.**

Implementing Agency/ Organization / Individual:

---

Agency / Organization / Individual Address:

---

---

Possible Partnering Agencies:

---

---

Contact Person Name:

---

Title:

---

Telephone:

Fax:

---

---

Email:

---

**Please provide the following information regarding the proposed project or program.  
Check the box that applies:**

Project (e.g. structural enhancements,  
infrastructure upgrades, etc.)

Program (e.g. policy updates,  
management suggestions, etc.)

Project or Program Name:

---

---

Project or Program Cooperating Agency/Organization(s), including potential funding sources  
(e.g., Kern County Water Agency, DWR/USBR Funding, environmental or agricultural groups):

---

---

---

---

---

Project Status (e.g., new, ongoing, expansion, new phase with brief description):

---

---

---

**Please provide the following information regarding the location of the project, including  
the name of the District(s) or Agency which has jurisdiction over the project area. If the  
proposal is for a non-structural program, please state the District(s) or Agency where the  
program will be implemented.**

Districts or Agencies (i.e., location corresponding to District or Agency service areas):

---

---

---

---

Description of Proposed Location:

---

---

---

---

---

Latitude (if available):

---

Longitude (if available):

---

## **2.0 Project/Program Description**

**Please provide a general description of the proposed project or program, including an assessment of the potential impacts and benefits of implementing the project or program. This section should provide information regarding the project concept, general project information, and readiness to proceed.**



If applicable, please list the existing water conveyance infrastructure associated with the proposed project or program:

---

---

---

---

Source of assumed increased supply or demand reduction (check all that apply):

- |  |   |   |
|--|---|---|
| <input type="checkbox"/> Surface Water (Supply Management) | <input type="checkbox"/> Groundwater Recharge (Storage/Banking) | <input type="checkbox"/> Conveyance/Delivery Efficiency |
| <input type="checkbox"/> Groundwater (Treatment)           | <input type="checkbox"/> Conservation/Water Use Efficiency      | <input type="checkbox"/> Conjunctive-Use Management     |
| <input type="checkbox"/> Transfer/Exchange                 | <input type="checkbox"/> Other (describe): _____                |   |

If applicable, please list any available documents which contain information specific to the proposed project or program (include conceptual plans, permits, drawings, and any technical documents):

---

---

---

---

For projects or programs ready for construction or implementation, briefly describe the readiness-to proceed:

---

---

---

---

---

Does the project have the potential to reduce dependence on water originating from the Sacramento-San Joaquin River Delta?

- Yes                       No                       Not Sure

Does the project address any known environmental justice issues?

- Yes                       No                       Not Sure

Is the project located within or adjacent to an *economically-disadvantaged community* (DAC)?

Yes

No

Not Sure

Does the project include DAC participation, or involvement from the DAC Representative or Work Group?

Yes

No

Not Sure

If yes, please identify the group, organization, or requested services of the DAC Representative or Work Group:

---

---

---

---

Please describe any benefits that the proposed project or program may have towards preparing the region for the presumed effects of climate change, see Section 13.0 of the 2019 IRWM Plan:

---

---

---

---

---



## **Project Definition and Characterization Form (PDCF)**

### *Project and Program Submission Form for the Poso Creek Integrated Regional Water Management Plan (IRWMP) 2019 Update*

Please mail completed form to the following address, or bring complete form to one of the regular IRWM meetings (as scheduled);

Poso Creek RWMG  
c/o Semitropic WSD  
1101 Central Avenue  
Wasco, CA 93280

For questions or concerns regarding the form, please contact:

Paul Oshel, Poso Creek IRWM Representative  
(661-758-5113)

### **1.0 Background Information**

**Please provide the following information regarding the project/program sponsor.**

Implementing Agency/ Organization / Individual:

---

Agency / Organization / Individual Address:

---

---

Possible Partnering Agencies:

---

---

Contact Person Name:

---

Title:

---

Telephone:

Fax:

---

---

Email:

---

**Please provide the following information regarding the proposed project or program.  
Check the box that applies:**

Project (e.g. structural enhancements,  
infrastructure upgrades, etc.)

Program (e.g. policy updates,  
management suggestions, etc.)

Project or Program Name:

---

---

Project or Program Cooperating Agency/Organization(s), including potential funding sources  
(e.g., Kern County Water Agency, DWR/USBR Funding, environmental or agricultural groups):

---

---

---

---

---

Project Status (e.g., new, ongoing, expansion, new phase with brief description):

---

---

---

**Please provide the following information regarding the location of the project, including  
the name of the District(s) or Agency which has jurisdiction over the project area. If the  
proposal is for a non-structural program, please state the District(s) or Agency where the  
program will be implemented.**

Districts or Agencies (i.e., location corresponding to District or Agency service areas):

---

---

---

---

Description of Proposed Location:

---

---

---

---

---

Latitude (if available):

---

Longitude (if available):

---

## **2.0 Project/Program Description**

**Please provide a general description of the proposed project or program, including an assessment of the potential impacts and benefits of implementing the project or program. This section should provide information regarding the project concept, general project information, and readiness to proceed.**

If applicable, please list the existing water conveyance infrastructure associated with the proposed project or program:

---

---

---

---

Source of assumed increased supply or demand reduction (check all that apply):

- |  |   |   |
|--|---|---|
| <input type="checkbox"/> Surface Water (Supply Management) | <input type="checkbox"/> Groundwater Recharge (Storage/Banking) | <input type="checkbox"/> Conveyance/Delivery Efficiency |
| <input type="checkbox"/> Groundwater (Treatment)           | <input type="checkbox"/> Conservation/Water Use Efficiency      | <input type="checkbox"/> Conjunctive-Use Management     |
| <input type="checkbox"/> Transfer/Exchange                 | <input type="checkbox"/> Other (describe): _____                |   |

If applicable, please list any available documents which contain information specific to the proposed project or program (include conceptual plans, permits, drawings, and any technical documents):

---

---

---

---

For projects or programs ready for construction or implementation, briefly describe the readiness-to proceed:

---

---

---

---

---

Does the project have the potential to reduce dependence on water originating from the Sacramento-San Joaquin River Delta?

- Yes                       No                       Not Sure

Does the project address any known environmental justice issues?

- Yes                       No                       Not Sure

Is the project located within or adjacent to an *economically-disadvantaged community* (DAC)?

Yes                                       No                                       Not Sure

Does the project include DAC participation, or involvement from the DAC Representative or Work Group?

Yes                                       No                                       Not Sure

If yes, please identify the group, organization, or requested services of the DAC Representative or Work Group:

---

---

---

---

Please describe any benefits that the proposed project or program may have towards preparing the region for the presumed effects of climate change, see Section 13.0 of the 2019 IRWM Plan:

---

---

---

---

---

### 3.0 Proposal Impacts and Benefits to Region

Please provide an estimate (quantitative and/or qualitative) of specific impacts or benefits realized by implementation of the proposed project or program. There does not necessarily have to be a model or study verifying these estimates, however, the applicant should be prepared to justify any of the identified impacts or benefits to the IRWM Group.

Total Project Area (acres)

Annual Yield (AF)

Annual Demand Reduction (AF)

Rehabilitated Land (acres)

Primary benefits/impacts anticipated during specific water-year types (check all that apply):

Median/Average Year       Dry Year (Drought)       Wet Year

Primary benefits/impacts anticipated during specific season (check all that apply):

Summer (Jun – Aug)       Fall (Sept – Nov)

Winter (Dec – Feb)       Spring (Mar – May)

**APPROX. TOTAL COST**

Annual O&M or Mgmt. Costs

Life of Project/Program (years)

Please provide a preliminary description of a schedule for project/program implementation:

---

---

---

---

---

**PROPOSED START DATE**



#### 4.0 IRWM Plan Measurable Objectives

Please indicate below whether the proposed project or program meets any of the Poso Creek IRWM Plan ‘Measurable Objectives’, as stated in Section 4.0 of the Plan. Where necessary/appropriate, please provide a brief explanation of how the proposal meets the objective(s).

		Met (check)	Comments/Description
A	Enhance reliability of surface water supplies delivered to region.		
B	Identify any significant threats to groundwater resources from overdrafting.		
C	Improve regional water conveyance, direct recharge, and in-lieu service areas.		
D	Increase absorptive capacity within the region.		
E	Promote regional conjunctive water-use.		
F	Support groundwater monitoring activities.		
G	Maintain and enhance quality of water supply.		
H	Enhance region-wide flood control measures.		
I	Promote environmental conservation and support wildlife habitat enhancement.		
J	Identify drinking water quality issues of communities, water-related needs of DAC's, and consider improvements.		

**Measurable Objectives (continued):**

		Met (check)	Comments/Description
K	Implement regional opportunities, projects, and programs.		
L	Implement region-wide water management actions.		
M	Maintain compliance with State and Federal planning requirements.		
N	Maintain coordination between Poso Creek RWMG Participants and Interested Parties.		
O	Adapt to changes in the amount, intensity, timing, quality, and variability of runoff and recharge.		
P	Reduce energy consumption, especially the energy embedded in water use, and ultimately reducing GHG emissions.		
Q	Consider strategies adopted by CARB in its AB 32 Scoping Plan 1.		
R	Consider options for carbon sequestration and using renewable energy for IRWM project implementation.		

The Poso Creek IRWM Group has defined the following Region Goals 1 through 7, as set forth in Section 4.4 of the 2019 IRWM Plan:

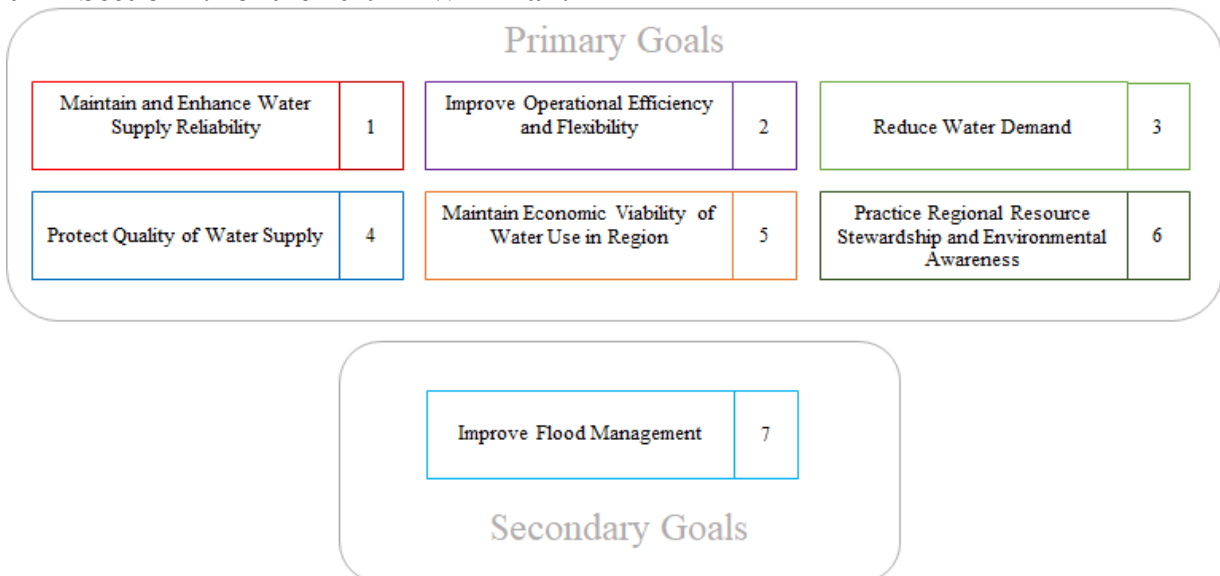

Please briefly describe which of these Regional Goals would be met by the proposed project or program:

---

---

---

---

---

# **Poso Creek IRWM Plan Public Involvement Plan (PIP)**

**Supplement to the 2019 Poso Creek Integrated  
Regional Water Management Plan Update**

**- June 2019 -**

## Table of Contents

PREFACE AND PURPOSE.....	3
PARTICIPANT ROLES AND RESPONSIBILITIES .....	5
APPROACH TO THE PUBIC INVOLVEMENT PLAN .....	7
Process used to identify and involve stakeholders.....	7
Role of disadvantaged communities.....	8
Use of technology and information access in communication.....	8
Stakeholder role in the RWMG decision making process.....	9
Stakeholder involvement in the IRWM Plan.....	10
Identification and coordination with neighboring IRWM Regions .....	11
Coordination with agencies .....	11
Communication Protocols.....	12
Metrics .....	12
Public Involvement Plan documentation.....	12
Appendix A.....	13
Members of the RWMG.....	13
Appendix B .....	14
IRWM Planning Activities within the Tulare Basin Funding Area .....	14
Appendix C .....	15
Initial List: Stakeholders, Plan Participants and Agencies.....	15
Appendix D.....	16
DAC organizations/Communities that have participated and/or benefitted from the Poso Creek IRWM Process .....	16

## PREFACE AND PURPOSE

This document outlines the Public Involvement Plan (PIP) approach used for Stakeholder Involvement and interregional Coordination for the Poso Creek Integrated Regional Management Plan 2019 Update (IRWM Plan Update). The IRWM Plan for the Poso Creek Region was first adopted in 2007. It was prepared by local interests who received grant funding through a California Department of Water Resources (DWR) Proposition 50 Planning Grant. The initial IRWM Plan was completed pursuant to a grant contract and Memorandum of Understanding (MOU) allowing time to establish mutual understandings among the Poso Creek Region IRWM participants and established the Regional Water Management Group (RWMG). Following the initial IRWM Plan development, the RWMG initiated implementation which included development of a Governance MOU designating roles for implementing the IRWM Plan over time and established the decision-making process. The Governance MOU contains the signatures of eligible agencies and organizations who serve as the Poso IRWM Plan “Regional Water Management Group” members. The RWMG is responsible for periodically updating the IRWM Plan. Since the original adoption, the 2007 Plan was updated in 2014 in compliance with the IRWMP Proposition 84 Program Guidelines and in 2019 per 2016 Proposition 1 IRWMP Program Guidelines. A second MOU has also been developed to formalize a change in governance in the form of the addition of the Southern San Joaquin Municipal Utility District (SSJMUD) to the RWMG.

The purpose of this PIP is to identify and document how participation and information sharing occurs throughout this IRWM Plan process. Implementation of the PIP documents the IRWM Plan’s efforts to meet DWR outreach requirements and promote agency, stakeholder, and disadvantaged community (DAC) involvement in this IRWM Plan. This PIP continues the successful IRWM process initiated by the RWMG that involved Stakeholder and DAC interests in the IRWM Plan development and includes these entities in the implementation activity. The PIP describes the timing and nature of communications that occur among the parties involved in the IRWM Plan process. The PIP is not intended to prescribe new protocol for the entities, i.e. the PIP does not establish communication guidelines for the RWMG. Rather the PIP describes the kinds and timing of communication used to facilitate both public involvement and coordination among the Poso IRWM Plan participants, among neighboring IRWMPs within the Tulare Basin Funding Regions, and among the IRWM state program. The PIP discusses:

- Scheduled meetings and public forums and the nature of materials used;
- RWMG response procedure to requests for information;
- Schedule of communications;
- Responsible entities for providing and circulating information; and
- Documentation of meetings and other communications.

In order to provide consistent and effective communication over time in the face of changing conditions, implantation of the PIP’s Communication and Outreach Plan identifies the procedures used to manage communication for the IRWM Plan. This Stakeholder Outreach Plan is an integral part of the overall IRWM Plan and is used as guidance for stakeholder engagement by the Poso Creek RWMG. The PIP identifies formal communication elements. Other communication channels exist on informal levels and enhance

those discussed within this PIP. Informal communications will enhance communication and are not intended to be limited by this PIP.

DWR has expanded the IRWM Plan standards since adoption of the 2007 Poso Creek IRWM Plan, and since adoption of the 2014 Poso Creek IRWM Plan Update. A revision of the IRWM plan is needed to address these expanded standards and to meet the contractual obligations of several of the Poso Creek RWMG members. DWR has listed 16 “Plan Standards” that must be addressed in developing or updating an IRWM Plan. Two of these standards, Stakeholder Involvement and Coordination, are directly addressed by this document. The specific Standards are contained in the January 2016 IRWM Grant Program Guidelines available at: <http://www.water.ca.gov/irwm/grants/>.

The IRWM Plan guidelines state “the intent of the [...] Stakeholder Involvement Standard is to ensure the RWMGs give the opportunity to all interested parties to actively participate in the IRWM decision-making process on an on-going basis.” In the guidelines, this is also meant to extend to Native American Tribes in addition to Stakeholders, but since there are no known Native American tribes in the Region, this is not applicable. To assure that the guidelines’ intent is met, they list a number to topics to address:

- Process used to Identify Stakeholders
- Involvement of Disadvantaged Communities
- Use of Technology and Information Access
- Decision Making Process
  - The groups or committees involved
  - The constitution of those groups
  - The opportunities to contribute to those groups or the decision-making process
- Stakeholder Involvement

The intent of the Coordination Standard is to ensure the following items:

- Coordination of activities with local agencies and stakeholders to avoid conflict within the region and to best utilize resources,
- Planning efforts and coordinating with RWMGs in adjacent Regions, and
- State, federal, and local agency resources and roles are considered in the implementation of their plans and projects.

The DWR Standards provide direction for three topics:

- Coordination of activities within an IRWM Region,
- Identification and coordination with neighboring IRWM Regions, and
- Coordination with agencies.

While the guidelines do not require a Public Involvement Plan, development of a PIP is a method to assure that elements of the Stakeholder Involvement and Coordination requirements are met. In addition, it is useful for documenting this activity to meet the DWR’s plan requirements.

## PARTICIPANT ROLES AND RESPONSIBILITIES

This section describes the organization, roles and responsibilities, communication, and established relationships among of the participating entities involved in the Poso Creek IRWM Plan. The participating entities include the Poso RWMG, Semitropic Water Storage District (WSD) as the Lead Agency, the DAC Representative, the DAC Working Group, and Interested Stakeholders.

1. The **Regional Water Management Group (RWMG)** is responsible for the IRWM Plan development and implementation. According to DWR, a RWMG must meet the definition per CWC §10539 which states,

*RWMG means a group in which three or more local agencies, at least two of which have statutory authority over water resources or water management, as well as those persons who may be necessary for the development and implementation of a plan that meets the requirements of the CWC §10540 and §10541, participate by means of a joint powers agreement, Memorandum of Understanding (MOU), or other written agreement, as appropriate, that is approved by the governing bodies of those local agencies.*

In the Poso Creek IRWM Region, the RWMG members must be either local agency as required by the CWC or an IRS defined 501 (c) 3 non-profit organizations. The RWMG members are signatories to the Governance MOU and will consider adopting the 2019 IRWM Plan Update. The RWMG comprises:

- Semitropic Water Storage District
- Cawelo Water District
- Delano-Earlimart Irrigation District
- Kern-Tulare Water District
- North Kern Water Storage District
- North West Kern Resource Conservation District
- Shafter-Wasco Irrigation District
- Southern San Joaquin Municipal Utility District
- DAC Representative

The RWMG member agencies and/or organizations' roles and responsibilities include:

- Execute and maintain Governance MOU
- Maintain, update, and adopt the IRWM Plan
- Designate a Chairman as representative with clear authority to represent agency/organization
- Attend public meetings/workshops
- Submit planning/implementation projects/programs for IRWM Plan and grant funding
- Compile and as necessary, submit data on planning/implementation projects/programs

The RWMG holds a public meeting on the first Tuesday of the month, as necessary. A list of RWMG representatives is shown in Appendix A.



Semitropic Water Storage District (Semitropic) acts as the **Lead Agency** that manages the IRWM Plan, submittal of the grant applications on behalf of the Region and acts as a liaison with DWR. Specifically, the roles and responsibilities of the Lead Agency are:

- Review and approval of IRWM Plan
- Coordinate re-adoption of IRWM Plan as needed
- Execute MOU
- Act as Lead Agency for Region
- Communicate decision on IRWM activities with RWMG
- Authorize grant applications
- Enter into agreements with DWR on behalf of RWMG
- Approve implementation agreements
- Approve funding for IRWM planning
- Approve contracts with consultant(s)

Semitropic hosts a public meeting of the RWMG on the first Tuesday of the month, as necessary; occasionally, the public meeting may be held at one of the other RWMG member locations to accommodate members of the RWMG, IRWM Plan participants, and the public.

2. **Interregional Coordination** occurs through engaged interaction of the RWMG with other representatives of adjacent IRWM Regions who meet on the first Monday of the Month in order to understand the specific water resources needs and priorities of the overall Funding Area Region, explore common Resource Management Strategies, and consider regional programs. A list of IRWM and other regional planning activities in the Tulare Basin Funding Area is shown in Appendix B.

3. **DAC Representation** is provided by an elected DAC Representative. The DAC Representative has a vote on the RWMG and coordinates with key DAC stakeholders who guide identification and development of DAC water related projects for inclusion on the IRWM Plan and grant proposals.

4. **Interested Stakeholders** provide valuable input into the planning process and inform the RWMG of potential project opportunities. In specific, the roles and responsibilities of the Interested Stakeholders are:

- Provide input into development of IRWM Plan
- Attend public meetings/ workshops
- Comment on Draft Sections of the Plan
- Provide letters of support for the Plan and Projects

Stakeholders are informed of the monthly RWMG meetings. A list of current Stakeholders in provided in Appendix C.

## **APPROACH TO THE PUBIC INVOLVEMENT PLAN**

This PIP includes communication and involvement with two groups of interests:

- Stakeholder interests within the Poso Creek IRWM Region, and
- Agency and other interests both within and outside the IRWM from adjacent Regions.

Differentiating between communication and involvement approaches for these two groups in the standards is in many ways an artificial construct; they are not mutually exclusive. However, the DWR guidelines do contain two distinct sets of standards. Therefore, this PIP discusses a series of approaches, some focusing on stakeholders within the Poso Creek Region and some focusing on coordination with interests and will generally use DWR terminology.

The discussion below will first focus on involvement of Stakeholder interests, specifically:

- Process used to identify and involve stakeholders
- The role of disadvantaged communities
- Use of technology and information access in communication
- Stakeholder role in the RWMG decision making process
- Stakeholder involvement in development of the IRWM Plan update

These topics comprise the first element of the coordination Standard:

- Coordination of activities within an IRWM Region.

The last two sections of the Approach discussion will address the second and third elements of the Coordination standard:

- Identification and coordination with neighboring IRWM Regions, and
- Coordination with agencies.

### **Process used to identify and involve stakeholders**

The RWMG developed an initial list and maintains an existing list of all relevant agencies and interest groups, including those statutorily required stakeholders (Appendices A, B and C). The list is augmented through formal and informal communications with stakeholders already on the list and through outreach communications. Communications include word of mouth, e-mail communication, requests for involvement through organizations such as Self-Help Enterprises, and Pubic Announcements.

The stakeholder outreach list informs the public and maintains a link for a consistent outreach process. It also serves as a tool moving forward into other media.

Stakeholders receive updates on the project and plan milestones, funding information, and other appropriate and relevant information. The stakeholder list was built from a considered list:

- Wholesale and retail water purveyors
- Wastewater agencies
- Flood control agencies
- Municipal and county governments and special districts
- Electrical corporations
- Native American tribes (None are within this IRWM Area)
- Self-supplied water users
- Environmental stewardship organizations
- Community organizations
- Industry organizations
- State, federal, and regional agencies or universities
- Disadvantaged community members
- Any other interested group appropriate to the region.

The stakeholder list is updated throughout the process and is open to new participants.

## Role of disadvantaged communities

The IRWM Plan relies on the DAC Representative of the RWMG to coordinate community needs; the DAC Representative coordinates the smaller disadvantaged community needs through Self Help Enterprises. This process incorporates the wealth of local knowledge, input, and priorities of the DACs in the region to identify the needs, priorities, actionable water management strategies, and potentially fundable projects. Other DAC representatives are encouraged to participate in the monthly RWMG meetings. However, the participation by the DAC Representative and by the key stakeholder, Self Help Enterprises, has led to a reliable and effective process to identify and address DAC water related needs.

The RWMG encourages identification of relevant Resource Management Strategies determined by the DAC representatives and development of projects specifically to benefit DACs. The Poso Creek RWMG continues to support the advancement of DAC projects within and in some cases, just outside the Region's boundaries. The RWMG is open to address any technical barriers to communication to assure the DAC issues are identified and defined in the IRWM update. A list of Disadvantaged Communities that have participated and, in many cases, benefitted from the Poso Creek IRWM process as provided as Appendix D of this document.

## Use of technology and information access in communication

**Methods of communication** – The RWMG relies on communication systems that are commonly utilized in the Region:

**E-Mail** - Each stakeholder is encouraged to provide an e-mail address. An E-mail list is used to circulate all notices and other relevant information including alerting entities to meetings, meeting changes, alerting entities to key documents that have been posted on the Poso IRWM website (<http://semitropic.com/PubsArchive.htm>). General questions and answers from the public are directed to the appropriate RWMG representative for information on the IRWM Plan.

**Conference calls** - Conference calls or other means are used for communication with entities such as DWR or to provide remote access to public meetings.

**Website** - The existing website is to be restructured to accommodate the IRWM Plan update and implementation process; once restructured, it will enhance existing communication.

**Published notices** - In addition to e-mail and web postings, the RWMG publishes notices to advise the public of certain formal actions such as the Notice of Intent to update the IRWM Plan.

**Formal Communication** - RWMG will use formal communications for certain items:

**Notice of Intent** – An example of a formal “Notice of Intent” (NOI) is an NOI to update the Poso Creek IRWM Plan. The NOI is publicly noticed in media publications in the County. The NOI is posted on the Poso Creek IRWM website and websites of RWMG members to provide widespread notice. In addition, the NOI is circulated to the Stakeholder list by e-mail.

**Public Meeting Notices** – Hearings, such as, for adoption of the revised Plan and certain meetings are publicly noticed to allow for public and stakeholder input. Routine meeting Notices are posted on the Poso Creek IRWM website ([Address here](#)) for public access.

**RWMG Meeting Notices** – RWMG meetings are held the first Tuesday of the month. Reminder notices are generated and sent out by email to the RWMG in advance of the actual meeting. The stakeholder list is copied on RWMG meeting notices to ensure the all interested parties are kept abreast of the progression on the Plan. Meeting Notices, Agendas and Meeting Minutes are posted on the Poso Creek IRWM website ([Address here](#)) for public access.

**Informal communications** - Informal communications occur during the IRWM Plan activities, update, and implementation. This informal process may consist of e-mail, conversations or phone calls and serve to supplement and expand communications. Informal communication is not intended to replace formal communications.

## **Stakeholder role in the RWMG decision making process**

Individual stakeholders and stakeholder organizations are critical to informing the IRWM process and supporting the RWMG in their development, update, and implementation of the Poso Creek IRWM Plan. Stakeholders provide input on matters pertaining to development, updating, and implementation of the IRWM Plan. In RWMG meetings, stakeholders may participate on discussion of agenda items and may provide comment on other matters on the agenda.

Stakeholders are expected to participate in development of regional Objectives and Resource Management Strategies. Stakeholders nominate projects for inclusion in the IRWM Plan through a district sponsor, the DAC Representative, and/or through a DAC Working Group that includes Self-Help Enterprises. DWR guidelines allow those stakeholder organizations, such as public agencies, to sponsor projects that address Plan objectives and with the concurrence of the RWMG.

## Stakeholder involvement in the IRWM Plan

Stakeholder involvement in development, updating, and implementing the IRWM Plan is encouraged and supported in several ways, including:

### RWMG Meeting Protocol

- Meeting agendas are prepared and distributed prior to the meeting.
- Meetings are coordinated by and facilitated by the RWMG Chairman and/or its designee.
- Meetings operate according to a set of ground rules.
- Progress toward completing work plan tasks is assured by adherence to time frames identified on meeting agendas.
- Meeting materials are coordinated and distributed ahead of the meeting time.
- Public comments are scheduled at the beginning of meetings.

### Stakeholder Involvement and Input with the RWMG to the IRWM Plan Process

- Clear and complete schedule
- Materials easily accessible and available on time
- Encourage Stakeholder input through review of interim work products and recommending actions and decisions to the RWMG.

**Encourage broader dissemination of IRWM related materials** - The RWMG encourages participants to utilize existing groups and communication systems to disseminate information about the IRWM plan, in part relying on groups that have dedicated involvement and similar concerns and/or issues as those addressed in the IRWM Plan.

**External Communications - Public Inquiries** - The public is encouraged to participate in the IRWM Plan development, update, and implementation. The NOI, as described above, is publicly distributed and both RWMG meetings and each district's Board hearings on the Plan are publicly noticed. In addition, all meeting information is posted on the website and available for public viewing and comments. Public comments are received via an e-mail address posted on the website and are answered by designated RWMG member or their authorized agents.

## Identification and coordination with neighboring IRWM Regions

Regular meetings of regional water planning entities within the Tulare Lake Funding Area are held the first Monday of the month. The entities involved are listed in Appendix B. The meetings are hosted by a coordinating group for Tulare Lake Hydrologic Region Water-Related Entities. Each participating Region provides participation by District staff involved directly in the IRWM process.

Participating parties in the monthly meetings include representatives of the Kings River Conservation District, Kings IRWM, Southern Sierra IRWM, Poso Creek IRWM, Tule IRWM, Kaweah IRWM, Westside IRWM, and the Kern IRWM. Meeting agendas are prepared by a consultant for the Tulare Lake Hydrologic Region Water-Related Entities.

## Coordination with agencies

The RWMG continues to foster and build relationships with other planning groups within the Central Valley; coordinating efforts include:

1. Meeting regularly as a RWMG focused on the Poso Creek IRWM Plan Implementation provides other IRWM groups with a functional implementation group to communicate with for implementing water management strategies that are larger than one planning group, such as, managing flood water from rivers adjacent to the Friant-Kern Canal in the Tulare Basin. These regular implementation meeting notices are distributed to a large group of districts and stakeholders and provide a designated time for the RWMG to listen to any interested parties.
2. Meeting regularly with neighboring established and developing IRWM groups within the Tulare Lake Hydrologic Region Water-Related Entities.
3. Supported the efforts of the *Partnership for the San Joaquin Valley* to develop an Action Plan that is a framework for planning for an eight-county area of the Central Valley. (<http://www.sjvpartnership.org/>).
4. Encouraging the DACs and Cities within the Poso Creek Region who are within the “North Group” of the Kern IRWM to join the Kern IRWM process and help build working relationships between the Kern IRWM and the Poso Creek IRWM Plan implementation groups.
5. Offering in-kind services and participating as a Stakeholder in the Kern IRWM process. Participating in the “Round Table of Regions” conference calls and IRWM coordination meetings.
6. Participating in semi-annual Tulare Lake Basin Working Group meeting that are led by Carole Combs, Executive Director, Tulare Basin Wildlife Partners and working with the TBWP to develop and implement wildlife projects in the Poso Creek Region.
7. Attending Reclamation’s Mid-Pacific Conference and presenting Plan materials at meetings with Reclamation planning staff.
8. Attending CA Irrigation Institute Annual Meeting and presenting projects.
9. Support of CV SALTS Program.
10. Presenting Plan information at technical conferences, such as, the United States Committee on Irrigation and Drainage.

The RWMG will continue to engage all water planning agencies within the region through these efforts. In addition, the RWMG will expand its coordination efforts through discussions with agencies responsible for Land Use Planning within the Region as the part of the Poso IRWM Plan.

## **Communication Protocols**

All IRWM Plan communications related to project-wide status is directed to the Poso RWMG Chairman, Dana Munn, unless otherwise specified. Because of the broad scope of this project, only those individuals at the project management level can provide a comprehensive and accurate status update on the project. Project status updates will be disseminated periodically through e-mail, as needed, to all entities or sub-groups. All meeting agendas, materials, and action items will be posted on the IRWM website for public review.

## **Metrics**

Appropriate metrics will be used to measure the Stakeholder involvement and communications to measure the success of this Public Involvement Plan. The metrics may include:

- Numbers of organizations or individuals involved (e.g. attending meetings)
- Range of interests shown by stakeholders
- Number of comments
- Scope of projects suggested to the RWMG
- Compliance with information/data requests
- Review of TMs, draft, and final drafts of plan according to schedule
- Agency participants provide current and accurate information about the Plan

The RWMG will consider a range of metrics for measuring the success of the overall IRWM planning process. A subset of those will be used by the RWMG to document success of the PIP.

## **Public Involvement Plan documentation**

Written communications received or generated by the project will be retained and stored in the IRWM Plan records and key communications posted on the IRWM website. Documents that document decisions will be posted on the IRWM website, archived, and retained for historical purposes. The Public Involvement Plan will be included in the updated IRWM Plan.

## Appendix A

### Members of the RWMG

Semitropic Water Storage District  
Isela Medina, District Engineer, Secretary/Treasurer RWMG

Shafter-Wasco Irrigation District  
Dana Munn, General Manager, Chairman RWMG

North Kern Water Storage District  
Ram Venkatesan, District Engineer, Vice-Chairman RWMG

Cawelo Water District  
David R. Ansolabehere, General Manager

Delano-Earlimart Irrigation District  
Eric E. Quinley, General Manager

Kern-Tulare Water District  
Steven C. Dalke, General Manager

Southern San Joaquin Municipal Utility District  
Roland Gross, Secretary/General Manager

North West Kern Resource Conservation District (NWKRCDD)  
Brian Hockett, District Manager

DAC Representative



## Appendix B

### IRWM Planning Activities within the Tulare Basin Funding Area

Westside Drainage – Functional equivalent IRWMP developed over years with assistance from Reclamation, received \$25M Implementation Grant

Kings Basin – Prop-50/84/1 Compliant IRWMP developed over years with assistance from DWR

Kaweah Delta – Prop-50 Compliant IRWMP, Prop 84/1 update in progress

Poso Creek – Prop-50 Compliant IRWMP, Prop 84/1 update in progress

Tule River – Prop 84/1 Compliant IRWMP in development

South Sierra – Prop 84/1 Compliant IRWMP in progress

Kern – Prop 84/1 Compliant IRWMP in progress

IRWM Coordination Group for Tulare Lake Hydrologic Region Water-Related Entities

## Appendix C

### Initial List: Stakeholders, Plan Participants and Agencies

#### Stakeholders and Plan Participants

- Allensworth Community Services District
- Buena Vista Water Storage District
- California Water Institute, CSU Fresno
- City of Buttonwillow
- City of Delano
- City of McFarland
- City of Shafter
- City of Wasco
- Community Water Center
- Friant Water Users Authority
- Lost Hills Water District
- Kern County Water Agency
- Kern County Board of Supervisors
- Kern National Wildlife Refuge
- Lost Hills Utility District
- Wonderful Farms
- R.L. Schafer and Associates
- Rosedale-Rio Bravo Water Storage District
- Semitropic Wildlife Improvement District
- Sequoia River Lands
- Southern San Joaquin Municipal Utility District
- Tulare Basin Wildlife Partners

#### State and Federal Agencies

- California Department of Fish and Game
- California Department of Water Resources
- U.S. Bureau of Reclamation

## Appendix D

### **DAC organizations/Communities that have participated and/or benefitted from the Poso Creek IRWM Process (See Table 3.7 in Chapter 3 for all entities)**

- Allensworth
- City of Buttonwillow
- City of Delano
- City of McFarland
- City of Shafter
- City of Wasco
- Community Water Center
- Lost Hills Utility District
- Self-Help Enterprises

## **APPENDIX I**

### **Kern County Storm Water Resource Plan December 2016**

# Kern Storm Water Resource Plan



**Kern County, California**

December 2016

Report prepared by:

EST. 1968

**PROVOST &  
PRITCHARD**

**CONSULTING GROUP**

*An Employee Owned Company*

# Kern Storm Water Resource Plan

Kern County, California  
December 2016

Prepared by:  
Provost & Pritchard Consulting Group  
1800 30<sup>th</sup> Street, Suite 280, Bakersfield, California 93301

**COPYRIGHT 2016 by PROVOST & PRITCHARD CONSULTING GROUP  
ALL RIGHTS RESERVED**

Provost & Pritchard Consulting Group expressly reserves its common law copyright and other applicable property rights to this document. This document is not to be reproduced, changed, or copied in any form or manner whatsoever, nor are they to be assigned to a third party without first obtaining the written permission and consent of Provost & Pritchard Consulting Group. In the event of unauthorized reuse of the information contained herein by a third party, the third party shall hold the firm of Provost & Pritchard Consulting Group harmless, and shall bear the cost of Provost & Pritchard Consulting Group's legal fees associated with defending and enforcing these rights.

**Report Prepared by:**

**Provost & Pritchard Consulting Group**

Jeff Eklund, PE

Len Marino, PE

Mike Day, PE

Gretchen Heisdorf, PE

Hilary Reinhard, PE

Trilby Barton

Cheryl Hunter

**Contact:**

Jeff Eklund, PE

Telephone: (661) 616-5900

# Table of Contents

List of Tables .....iv

List of Figures.....iv

Abbreviations ..... v

Executive Summary ..... ES-1

1 Introduction..... 1-1

    1.1 Background ..... 1-1

    1.2 Purpose and Need..... 1-1

    1.3 Goals and Objectives..... 1-2

2 Watershed Identification..... 2-1

    2.1 Watershed Boundaries..... 2-2

    2.2 Internal Boundaries/Neighboring Watersheds not included in the Plan ..... 2-2

    2.3 Water Quality Priorities..... 2-3

    2.4 Surface and Groundwater Resources ..... 2-4

    2.5 Local Water Suppliers..... 2-4

    2.6 Native Habitat, Water Bodies, and Open Space..... 2-1

    2.7 Natural Watershed Process Interruptions ..... 2-3

3 Compliance with Water Quality Standards ..... 3-1

    3.1 Compliance Requirements for Plan Implementation ..... 3-1

        3.1.1 CEQA Compliance..... 3-2

        3.1.2 California Health and Safety Code ..... 3-3

        3.1.3 Water Rights ..... 3-4

        3.1.4 Local Water Quality ..... 3-5

    3.2 Proposed Modification(s) of an Existing Stream Bed or Channel ..... 3-7

    3.3 Monitoring Plan Requirements ..... 3-7

        3.3.1 Data Collection..... 3-7

        3.3.2 Integration into Existing Monitoring Efforts ..... 3-8

        3.3.3 Multiple Separate Storm Sewer System (MS4) Projects ..... 3-9

4 Organization, Coordination and Collaboration..... 4-1

    4.1 Introduction and Overview ..... 4-1

    4.2 Regional Water Management Groups Implementing Existing IRWM Plans ..... 4-1

        4.2.1 Overview of Kern IRWMP ..... 4-1



4.2.2	Overview of Poso Creek IRWMP .....	4-1
4.3	Stakeholder Agencies that Participated in Plan Development .....	4-2
4.3.1	Stakeholder Agencies.....	4-2
4.4	Nonprofit Organizations .....	4-4
4.5	Public Engagement/Communication Plan and Coordination .....	4-4
4.5.1	Overview of Public Engagement/Communication Plan .....	4-4
4.5.2	Public Meetings during Plan Development.....	4-5
4.6	Local, State, Federal Decisions, Code Changes or Legislations Needed for Plan Implementation .....	4-7
4.6.1	Local, State and Federal Decisions, Code Changes or Legislations .....	4-7
4.6.2	Federal, State or Local Agency Interaction for Permitting and Environmental Processes.....	4-8
4.7	Planning and Coordination among Existing Local Government Agencies for Plan Implementation .....	4-10
4.8	Relationship of Plan with Other Existing Planning Documents .....	4-10
4.8.1	Projects within the Kern Region & Relationship with Existing IRWMP Documents .....	4-10
4.8.2	DAC Studies within Kern Region .....	4-11
4.8.3	Other Existing Planning Documents, Ordinances and Programs.....	4-13
5	Identification and Prioritization of Projects .....	5-1
5.1	Introduction .....	5-1
5.2	Project Submittal Form – Purpose and Use .....	5-1
5.3	Project List Unranked – Side-by-Side Comparison of Submitted Projects.....	5-2
5.4	Project Scoring Form – Description of Scoring Methodology .....	5-8
5.4.1	Main and Additional Benefits Scoring .....	5-8
5.4.2	Project Readiness Scoring.....	5-9
5.5	Prioritized List of Projects .....	5-10
5.6	Process for Submitting New or Modifying Existing Project Proposals.....	5-13
5.6.1	New Project Proposals .....	5-13
5.6.2	Modifications or Revisions to Existing Project Proposals.....	5-13
6	Implementation Strategy and Schedule .....	6-1
6.1	Resources for Plan Implementation.....	6-1
6.1.1	Project Funding.....	6-1
6.2	Implementation .....	6-7

6.2.1	SWRP Project Monitoring.....	6-8
6.3	Adaptive Management.....	6-8
7	Education, Outreach and Public Participation.....	7-1
7.1	Public Outreach and Participation Opportunities.....	7-1
7.1.1	Identifying Key Stakeholders .....	7-1
7.1.2	Public Outreach/Participation Actions .....	7-1
7.2	Involvement of Disadvantaged and Climate Vulnerable Communities.....	7-4
7.2.1	Communicating with and Educating DACs .....	7-4
7.3	Addressing Environmental Injustice Issues.....	7-5
7.4	Public Engagement and Education Schedule .....	7-5
8	SWRP Checklist and Self-Certification.....	8-1
8.1	Checklist Instructions .....	8-1
8.2	Declaration and Signature.....	8-9
9	References.....	9-1
	Figures .....	F-1
	Appendix A: Project Submittal Form Template .....	A-1
	Appendix B: Project Submittal Forms.....	B-1
	Appendix C: Project Scoring Forms.....	C-1
	Appendix D: Recharge to Groundwater, Groundwater Quality Assessment Report.....	D-1
	Appendix E: List of Individuals and Entities that Provided Comments on Draft SWRP .....	E-1

# List of Tables

Table 2-1. Kern County RWMG Participants .....	2-1
Table 2-2. Poso Creek RWMG Participants.....	2-2
Table 2-3. 2010 303(d) List of Impaired Water Bodies within Kern County .....	2-3
Table 2-4. Urban Water Suppliers within the Kern SWRP .....	2-5
Table 2-5. Non-Potable Water Suppliers within the Kern SWRP .....	2-1
Table 2-6. Kern IRWMP Table 2-20, Summary of Agricultural Water Demand (AFY).....	2-4
Table 3-1. Phase II Traditional and Non-Traditional Permittes.....	3-10
Table 4-1. Stakeholder Agencies and Organizations .....	4-2
Table 4-2. Board Actions, Code Changes, or Legislation Required for SWRP Projects .....	4-8
Table 4-3. Storm Water Resource Projects .....	4-11
Table 4-4. Disadvantaged Communities within the SWRP Boundary.....	4-12
Table 4-5. DAC Involvement .....	4-13
Table 4-6. Other Existing Planning Documents Associated with Kern SWRP Projects .....	4-14
Table 5-1. Summary of Proposed Projects .....	5-3
Table 5-2. Prioritized List of Projects.....	5-11
Table 5-3. IRWMP Group Contacts for Project Submittals.....	5-13
Table 7-1. DACs Affected by Potential Projects .....	7-4
Table 8-1. Storm Water Resource Plan Checklist and Self-Certification .....	8-1

# List of Figures

Figure 1. Kern SWRP Watershed Boundary Map .....	F-1
Figure 2. Water Agencies within the Kern Region .....	F-2
Figure 3. Major Water Management Facilities within the Kern Region .....	F-3
Figure 4. IRWMPs Surrounding the Kern Region .....	F-4
Figure 5. Groundwater Basins within the Kern Region.....	F-5
Figure 6. Groundwater Recharge Areas of the Kern Region.....	F-6
Figure 7. Flood Water Capture and Distribution Infrastructure for Poso Creek IRWM Group.....	F-7
Figure 8. Cities and Communities within the Kern Region .....	F-8
Figure 9. Disadvantaged Communities within the Kern Region.....	F-9

# Abbreviations

AB	Assembly Bill
ADWT	Advanced Water Treatment Grant
AF	Acre Foot
AF/yr, AFY	Acre-feet/year
Air District	San Joaquin Valley Air Pollution Control District
AWMC	Ag Water Management Council
Basin Plan	Water Quality Control Plan for Tulare Lake Basin
BMP	Best Management Practices
Bulletin 160	California Water Plan
BVWSD	Buena Vista Water Storage District
CASGEM	California Statewide Groundwater Elevation Monitoring
CDFW	California Department of Fish and Wildlife
CEQA	California Environmental Quality Act
CERES	California Environmental Resources Evaluation System
CESA	California Endangered Species Act
cfs	Cubic-foot per second
Comm	Community
CPUC	California Public Utilities Commission
CSD	Community Services District
CUWCC	California Urban Water Conservation Council
CV	Central Valley
CVC	Cross Valley Canal
CVCAC	Cross Valley Canal Advisory Committee
CVP	Central Valley Project
CVRWQCB	Central Valley Regional Water Quality Control Board
CV-SALTS	Central Valley Salinity Alternatives for Long-term Sustainability
CWA	Clean Water Act
CWSRF	Clean Water State Revolving Fund
DAC	Disadvantaged Communities
DCP	Dust Control Plan
DDW	State Water Resources Control Board Department of Drinking Water

# Kern Storm Water Resource Plan

---

DOI.....	U.S. Department of Interior
DWR .....	Department of Water Resources
EDA.....	Economically Distressed Areas
Env .....	Environmental
EPA .....	U.S. Environmental Protection Agency
FEMA.....	Federal Emergency Management Agency
FM .....	Flood Management
GAMA .....	Groundwater Ambient Monitoring and Assessment
GAR.....	Groundwater Quality Assessment Report
GHG .....	Greenhouse Gas Emissions
Ledger .....	11-inch by 17-inch
ILRP.....	Irrigated Lands Regulatory Program
IPR .....	Indirect Potable Reuse
IRWM .....	Integrated Regional Water Management
IRWMP .....	Integrated Regional Water Management Plan
ISR.....	Indirect Source Review
KCWA .....	Kern County Water Agency
Kern Region .....	Combined geographic Kern and Poso Creek IRWMP areas
KFMC .....	Kern Fan Monitoring Committee
M&I.....	Municipal & Industrial
MEP .....	Maximum Extent Practicable
MGD .....	Millions of gallons per day
MOU .....	Memorandums of Understanding
MS4 .....	Municipal Separate Storm Sewer System
MWH .....	Megawatt-hour
NEPA .....	National Environmental Policy Act
NGO.....	Non-Government Organization
No. ....	Number
NOI .....	Notice of Intent
NPDES .....	National Pollutant Discharge Elimination System
NPS .....	Non-point sources
NRCS.....	Natural Resources Conservation Service
O&M.....	Operations & Maintenance

P2.....	Pollution Prevention
Plan .....	Kern Storm Water Resource Plan
PSF .....	Project Submittal Form
PSP .....	Proposal Solicitation Package
RWMG .....	Regional Water Management Group
SB .....	Senate Bill
SDWA .....	Safe Drinking Water Act
SDWSRF .....	Safe Drinking Water State Revolving Fund
SRA .....	Source Reduction Assistance
SRF .....	State Revolving Fund
SWAMP .....	Surface Water Ambient Monitoring Program
SWGP .....	Storm Water Grant Program
SWP .....	State Water Project
SWPAO .....	State Water Project Analysis Office
SWPPP .....	Storm Water Pollution Prevention Plan
SWRCB .....	State Water Resources Control Board
SWRP.....	Storm Water Resource Plan
TDS.....	Total Dissolved Solids
TMDL.....	Total Maximum Daily Load
USACE .....	U.S. Army Corps of Engineers
USBR .....	U.S. Bureau of Reclamation
USDA .....	U.S. Department of Agriculture
USFS .....	U.S. Forest Service
USFWS .....	U.S. Fish & Wildlife Service
USGS.....	United States Geological Survey
Ventura .....	Watersheds Coalition of Ventura County
WaterSMART .....	Sustain and Manage America’s Resources for Tomorrow
WD .....	Water District
WDR .....	Waste Discharge Requirements
WQ .....	Water Quality
WS .....	Water Supply
WSD .....	Water Storage District
WWTP.....	Wastewater Treatment Plant

# Executive Summary

This Storm Water Resource Plan (SWRP or Plan) was written to begin the process of formulating a regional plan for storm water and dry weather run-off (referred to collectively as “storm water”) projects for augmenting surface water supplies, improving water quality, and reducing the need for groundwater pumping. The capture and use of storm water is now considered to be a new way of looking at a resource previously regarded as negatively impacting people and property and addressed by quick disposal through drainage control structures and, in some cases, eventual routing out to sea. In the drought-stricken State of California, the State Legislature has made changes to the Water Code to encourage use of storm water as a resource rather than a nuisance. To that end, the state has developed programs under Proposition 1 which directs grant funding to programs designed to encourage development of projects which capture and re-use storm water for groundwater recharge, banking, and other beneficial uses.

The Plan was developed for the benefit of the Kern and Poso Creek Integrated Regional Water Management (IRWM) Groups and encompasses their combined boundaries. The Plan includes a comprehensive review and description of watersheds located within the Plan boundaries. It describes both surface and groundwater resources, water suppliers, and watershed priorities. Following the State Water Resources Control Board (SWRCB) Guidelines, natural habitat, existing water bodies, open space and watershed processes are reviewed and presented. The Plan addresses how water quality standards will be complied with and includes provision for modification of stream channels or lake beds and addresses Plan requirements for monitoring, data collection and management.

The Plan includes a section on collaboration and coordination amongst the member agencies and stakeholder entities that may have an interest in the Plan development. The original communication mechanism set forth in the Kern and Poso Creek IRWMP groups was retained and will continue to make use of these two groups’ websites, email list-servers, and meeting protocols familiar to many stakeholders within Plan boundaries. None of the communication or governance protocols codified by Memorandum of Understanding (MOU) of the participating IRWMP groups would be affected by implementation of the Plan.

The Plan authors encouraged participants to submit proposed projects using a Project Submittal Form (PSF) template designed with guidance from SWRCB Guidelines for capturing proposed project concepts and quantifying project benefits. The PSFs were developed specifically for this Plan, and stakeholders provided reviews and constructive comments to the PSF format and content during the first of two public meetings. A total of 12 project proposals were submitted for inclusion in the Plan. The Plan contains an explanation of the project scoring, ranking, and prioritization rubric. The rubric methodology was submitted for review and comment to stakeholders during the second public meeting. A project implementation strategy and schedule was developed, which encourages the submission of additional projects or modification of existing proposed projects for future updates to the Plan. One of the Plan goals and requirement of the guidelines is to produce a living document which can be used for many years and adapted to the changing needs and resource goals for the Kern Region.

# 1 Introduction

## 1.1 Background

Increasing development and environmental demands on water availability, coupled with curtailments of imported State Water Project (SWP) and Central Valley Project (CVP) deliveries due to drought and regulatory restrictions, have intensified the competition for available water supplies in the Kern Region. There is a continuing need to maintain a water resources management plan and strategy that addresses the needs of both municipal and industrial (M&I) purveyors and agricultural water users. Reliable, high quality water supplies are necessary to serve continually expanding urban needs as well as agricultural demand for reasonably-priced irrigation and groundwater recharge water.

With the exception of a few areas, the Tulare Lake Hydrologic Region of Kern County is a closed basin in that water entering the basin does not return to a salt sink after use, thus allowing opportunities for robust recycling, capture, and conjunctive use programs. A few years ago, several water storage districts and local government agencies formed Integrated Regional Water Management Plan (IRWMP) areas in contiguous parts of Kern and Tulare counties. The purpose of the IRWMPs is to develop a cooperative regional framework, implementation plan, and regional context for managing water resources in the Kern Region. The region is ideal for ongoing integrated regional water management. Water districts and government agencies in Kern County have successfully implemented regional projects and are interested in continuing to build projects to increase available water supply, improve water quality, reduce local flood risk, and enhance the natural habitat and the community's open space resources.

Senate Bill (SB) 985, the Storm Water Management Planning Act, implemented through Water Code section 10563, substantively focuses on diverting runoff from existing storm drains, channels, or conveyance structures to sites (particularly publicly owned sites) that can clean, store, infiltrate and/or use the runoff. A watershed-based Storm Water Resource Plan must comply with the relevant Water Code provisions enacted by SB 985, in order for individual storm water and dry weather runoff capture projects in the Plan to be eligible for bond funds. Funding for construction of watershed projects is available from the State of California through Proposition 1, the water bond measure approved by voters in November 2014, which authorized \$200 million in grant funding for multi-benefit storm water management projects. Water code section 10563, subdivision (c) (1) requires a SWRP as a condition for receiving funds for storm water and dry weather runoff capture projects from any bond measure approved by voters after January 2014. Agencies within two local IRWMPs, the Kern IRWMP and Poso Creek IRWMP, agreed to jointly develop this Plan as a collaborative means for securing grant funds for constructing watershed projects beneficial to many stakeholders.

## 1.2 Purpose and Need

Effective storm water planning and management on a watershed basis involves collaboration of local and regional governments, utilities, and other stakeholder groups to analyze the hydrology, storm drain/runoff conveyances systems, opportunity sites, as well as habitat or community needs



within sub-watersheds. The intent of a SWRP is to use a watershed-based approach to integrate storm water management and dry weather runoff capture to accomplish watershed goals and objectives. The watershed approach is essential to integrate storm water management with other basic aspects of aquatic resource protection and overall water management including flood control, water supply, and habitat conservation.

This Plan addresses existing regional watershed issues, identifies natural watershed processes and problems, and presents solutions to problems by proposing projects including those that are connected to regional water conveyance facilities. For the Kern SWRP, agencies within the Kern and Poso IRWMPs were called upon to propose projects using a standardized Project Submittal Form for inclusion in the Kern SWRP (see **Appendix A: Project Submittal Form Template**). The proposed projects submitted by these agencies are described conceptually in the Project Submittal Forms included in **Appendix B: Project Submittal Forms**. The Project Submittal Forms provide high-level project profiles, enabling each project to be evaluated and ranked for prioritization of implementation.

When the initial Plan was published in December 2016, 12 proposed projects were incorporated. Nine of the 12 projects present groundwater recharge proposals varying from 577 to 20,000 acre-foot/year (AF/yr) average annual water supply yield gained by storm water runoff capture. These nine projects have the potential of reducing dependence Delta imports as well as reduce flood risk, while enabling seasonal wetlands to thrive on land which would otherwise be dry and fallow. The remaining three projects are stream restoration and habitat production projects. These projects improve existing watershed processes by enhancing flows, reducing water temperature, and improving water quality at receiving reservoirs.

The Plan is intended to be structured as a living document in which new projects can be proposed while existing projects can be modified to adapt to changing conditions in the Kern Region. The Project Submittal Form template is included as **Appendix A: Project Submittal Form Template** and will be used for future submittals following publication of this Plan document.

## 1.3 Goals and Objectives

Adoption of this Plan will improve water supply availability and water quality by enhancing the natural processes resulting in ground water recharge and aquifer replenishment. Also, the reduction of downstream hydromodification and destabilization of surface water bodies will be realized due to control of unchecked runoff. The Plan goals include, but are not limited to:

- Implement a watershed-based approach to managing storm water and dry weather runoff by replicating natural hydrology and watershed processes onsite where rainfall occurs
- Realize multiple benefits by reducing runoff volume to receiving waters, thus reducing the pollutants discharged
- Realize non-measurable social and community benefits not obtained with traditional projects

Objectives for achieving the goals include:

- Augment the supply of freshwater to surface water bodies and enhance stream flows (that are hydrologically connected to groundwater aquifers) by developing projects consistent with the Plan goals
- Improve conditions for aquatic life and wildlife habitats
- Recharge groundwater aquifers through pervious urban or agricultural areas to support sustainable groundwater levels and increase local water supplies by developing projects consistent with the Plan goals
- Provide a supply of freshwater to increase recreational uses
- Harvest rainwater for augmenting groundwater and local water supplies
- Reduce or minimize erosion and land destabilization caused by runoff
- Reduce or minimize hydromodification of streams, rivers, wetlands, lakes caused by runoff

## 2 Watershed Identification

The Kern Region watershed includes watersheds of the member agencies of the Regional Water Management Groups (RWMG) that developed and that are implementing the Kern County and Poso Creek IRWMPs, which are located in the Tulare Lake Basin hydrologic region. The Tulare Lake Basin includes portions of Fresno, Tulare and Kings Counties.

The Kern County RWMG includes the following participants:

Table 2-1. Kern County RWMG Participants

Kern County RWMG Participants		
City of Arvin	Arvin Community Services District	Arvin-Edison Water Storage District
City of Bakersfield Water Resources Division	Bear Valley Community Services District	Belridge Water Storage District
Berrenda Mesa Water District	Buena Vista Water Storage District	Buttonwillow County Water District
California Water Service, Bakersfield	California Water Service, Kern River Valley District	Casa Loma Water Company
City of Delano	Desert Mountain Resource Conservation and Development Council	Dudley Ridge Water District
East Niles Community Service District	Frazier Park Public Utility District	Golden Hills Community Services District
Greenfield County Water District	Henry Miller Water District	Kern County Water Agency (KCWA)
Kern County Resource Management Agency	KCWA Improvement District No.4 (ID4)	Kern Delta Water District
Kern Water Bank Authority	Lamont Public Utility District	Lamont Stormwater Utility District
Lebec County Water District	Long Canyon Water Company	Lost Hills Utility District
Lost Hills Water District	City of Maricopa	City of McFarland
Mettler County Water District	Mountain Mesa Water Company	North of the River Municipal Water District
North West Kern Resource Conservation District	Oildale Mutual Water Company	Olcese Water District
Rainbird Valley Mutual Utility Company	Rosedale Rio Bravo Water Storage District	City of Shafter
Stallion Spring Community Services District	City of Taft	City of Tehachapi
Tehachapi-Cummings County Water District	Tehachapi Resource Conservation District	Tejon-Castac Water District
Valley Estates Property Owners Association	Vaughn Water Company	City of Wasco
West Kern Water District	Wheeler Ridge Maricopa Water Storage District	

The Poso Creek RWMG includes the following agencies:

**Table 2-2. Poso Creek RWMG Participants**

Poso Creek RWMG Participants		
Semitropic Water Storage District	Cawelo Water District	Delano-Earlimart Irrigation District
Kern-Tulare Water District	North Kern Water Storage District	Shafter-Wasco Irrigation District
North West Kern Resource Conservation District	Disadvantaged Community (DAC) Representative*	Southern San Joaquin Municipal Utilities District

\*See Section 4, Table 4-4.

## 2.1 Watershed Boundaries

The overall watershed boundary (shown on **Figure 1**) is the portion of the Tulare Lake Basin hydrologic region that is within Kern County, plus Dudley Ridge Water District in Kings County and portions of Tulare County within Delano-Earlimart Irrigation District and Kern-Tulare Water District (see **Figure 2**). The boundary within Kern County is consistent with the Tulare Lake Hydrologic Basin Planning Area boundary delineated by the Central Valley Regional Water Quality Control Board (CVRWQCB), and the California Water Plan (Bulletin 160) Hydrologic Region. The overall boundary is consistent with the combined boundary of the Kern County and Poso Creek IRWMP boundaries.

A large portion of the San Joaquin Valley groundwater basin underlies the watershed boundary. The San Joaquin Valley groundwater basin is in a critical state of overdraft. Therefore beneficial storm water management by member agencies that recharge the groundwater basin or otherwise contribute positively to groundwater balance will potentially benefit others within the region (see **Section 2.4**).

A network of regional and agency water conveyance systems plus wells, reservoirs, groundwater recharge and banking projects have been developed and are employed to conjunctively manage surface water and groundwater. Major water management facilities are shown on **Figure 3**.

## 2.2 Internal Boundaries/Neighboring Watersheds not included in the Plan

**Figure 4** shows the surrounding IRWMPs. The Kern SWRP boundary is adjacent to eight other IRWM planning regions: Southern Sierra, Inyo-Mono, Antelope Valley, Fremont Basin, Upper Santa Clara River, the Watersheds Coalition of Ventura County (Ventura), Santa Barbara, and San Luis Obispo. Overlapping areas exist within two of these Regions: (1) San Luis Obispo, and (2) Antelope Valley.

Members of the Kern and Poso Creek IRWMPs have a long history of open communication and coordination of storm water, surface water, and groundwater management on inter-regional, regional and local scales, which predate the IRWM program. Inter-regional and regional coordination and communication is evident in the development and operations of water management facilities, numerous joint groundwater recharge and banking programs, plus the many exchanges and transfers of water supplies between various agencies, including urban and agricultural purveyors, as well as

participation in local and state programs including many water management committees and meetings.

A number of cities, water districts, irrigation districts and other agencies have not opted to participate in the Kern SWRP but will be able to submit projects for consideration. The reasoning for non-participation ranged from non-applicability to lack of defined projects at this time. These agencies are free to ask for inclusion at a later date.

## 2.3 Water Quality Priorities

Pollution can enter a water body from point sources like wastewater treatment plants (WWTP) and/or other industries that directly discharge to the streams and from nonpoint sources over a broad area, such as runoff from a city and/or agricultural farmland or grazing areas located adjacent to stretches of a stream. Some non-point source (NPS) contaminants are naturally occurring in local rocks and soil, such as salts, boron, and heavy metals, (arsenic, chromium, selenium). Natural sources of nitrates also occur. The Federal Clean Water Act (CWA) contains two strategies for managing water quality including: (1) a technology-based approach that envisions requirements to maintain a minimum level of pollutant management using the best available technology; and (2) a water quality-based approach that relies on evaluating the condition of surface waters and setting limitations on the amount of pollution that the water can be exposed to without adversely affecting the beneficial uses of those waters. Section 303(d) of the CWA requires that the states make a list of waters that are not attaining standards after the technology-based limits are put into place. Impaired water bodies, with Total Maximum Daily Load (TMDL) assignments, within Kern County are listed in **Table 2-3** below.

The federal CWA, as well as the State Porter-Cologne Water Quality Control Act, requires water quality control plans to establish water quality standards which address beneficial uses of water sources. The CVRWQCB has established and adopted the Water Quality Control Plan for the Tulare Lake Basin (Basin Plan). The Basin Plan describes designated beneficial uses to be protected, water quality objectives to protect those uses, and a program of implementation needed for achieving the objectives. Beneficial uses, together with their corresponding water quality objectives, address federal regulatory criteria for water quality standards. Hence, the Basin Plan serves as regulatory references for meeting both state and federal requirements for surface and groundwater water quality control in the Tulare Lake Basin.

Table 2-3. 2010 303(d) List of Impaired Water Bodies within Kern County

2010 303(d) List of Impaired Water Bodies within Kern County (TMDL only)					
Water Body	Pollutant	Typical Data Range	Basin Plan Objective	Size	TMDL Completion
Isabella Lake	Dissolved Oxygen	0.8-11.0 mg/L	No Sample < 5.0 mg/l	123 acres	2021
	pH	7.3-9.6	6.5 – 8.5		

State Water Resources Control Board, 2010, [http://www.waterboards.ca.gov/water\\_issues/programs/tmdl/integrated2010.shtml](http://www.waterboards.ca.gov/water_issues/programs/tmdl/integrated2010.shtml)

Local surface water is supplied primarily by the Kern River and is considered to be high in quality. The only area with a surface water concern, within Kern County, is Lake Isabella for dissolved

oxygen and pH. Both pollutants are listed on the 303(d) Impaired Water Body List. There are other impairments identified for both Lake Isabella and the Kern River but are not listed on the 303(d) list.

The water quality of imported water is governed by the California Department of Water Resources (DWR) via the SWP and by the United States Bureau of Reclamation (USBR) via the CVP. Water provided by the SWP currently meets the applicable water standards as determined by DWR, but is occasionally compromised by seawater intrusion in the Delta and by impaired runoff from west side streams. Water provided by the CVP is a blend of water sources and can have water quality concerns due to impairment of the sources or conveyance facilities. Currently, the water meets the applicable water quality standards as determined by USBR, but is occasionally compromised by exchanges of their source water.

Groundwater quality is considered acceptable for most of the beneficial uses in much of the area. Some areas have impairments that affect beneficial uses. In some areas, these can be mitigated through blending water sources or treatment. Salinity and nitrates are the region's biggest concerns. Agricultural crops can be highly sensitive to high concentrations of salt and therefore require larger quantities of water to flush excess salt from the crop root layers.

Other pollutant concerns include arsenic, metals, and pesticides. Treatment options for these constituents, as well as salts and nitrates are usually very costly, so blocking impairment sources and/or blending with higher quality water are often employed as options before treatment.

## 2.4 Surface and Groundwater Resources

Water supplies utilized in the region are from the SWP via the California Aqueduct, the CVP via the Friant-Kern Canal, and local surface supplies from the Kern River and other local streams including Poso Creek, as well as the groundwater basin. Other groundwater basins in the Kern Region include the Kern River Valley groundwater basin to the east; Walker Basin Creek Valley groundwater basin to the southeast; Cummings Valley, Brite Valley, and Tehachapi Valley West/East Basins on the eastern side of the Region; and Cuddy Canyon Valley, Cuddy Ranch Area, Cuddy Valley; and Mil Potrero Area basins to the south. All of these groundwater basin boundaries are within the watershed boundary of the Kern Region (see **Figure 5**). Recently, the White Wolf groundwater sub-basin (a portion of the Kern basin isolated by the White Wolf fault) has been recognized as its own groundwater basin for groundwater sustainability planning purposes. **Figure 6** shows existing groundwater recharge sites, many of which are hydraulically connected to the groundwater basins and will be linked to the proposed projects included in Section 5.

A complete discussion on groundwater basins and groundwater recharge capability within the region is included in **Appendix D: Recharge to Groundwater**, which was excerpted from the Kern River Watershed Coalition Authority Groundwater Quality Assessment Report (GAR).

## 2.5 Local Water Suppliers

The wholesale and retail water purveyors, wastewater agencies, flood management agencies, and special districts of the Kern Region are involved in the development and implementation of the objectives and projects for this SWRP. Many agencies function as both water purveyors and flood

management agencies. Their participation was focused particularly on the water supply and flood management issues pertaining to the region. These agencies include, but are not limited to SWP districts (Kern County Water Agency [KCWA] and its 13 member units plus Dudley Ridge Water District), Kern River districts (i.e., North Kern Water Storage District, Kern Delta Water District), CVP districts (i.e., Delano-Earlimart Irrigation District, Arvin-Edison Water Storage District, Shafter-Wasco Irrigation District, etc.), groundwater supplier districts (cities and smaller water suppliers like the Vaughn Water Company and Casa Loma Water Company, and community services districts such as Bear Valley Community Services District and Golden Hills Community Services District). Municipal and county governments and special districts include local jurisdictions and land use planning agencies that were involved in the identification of issues, formation of objectives, and development of projects of this SWRP.

**Table 2-4** below lists the potable water suppliers within the Kern Region. Non-potable water suppliers within the Kern Region are listed in **Table 2-1** and are shown geographically in **Figure 2**.

**Table 2-4. Urban Water Suppliers within the Kern SWRP**

Potable Water Use within the Kern SWRP			
Water Supplier	2010 Volume (Est.)*	Water Supplier	2010 Volume (Est.)*
Arvin Community Services District	3,472	Lake of the Woods Mutual Water Company	
Bear Valley Community Services District	956	Lamont Public Utility District	4,865
Buttonwillow County Water District	142	Lebec County Water District	
California Water Service, Bakersfield	77,177	Long Canyon Water Company	
California Water Service, Kern River Valley District	1,106	Lost Hills Utility District	462
Casa Loma Water Company		Mettler County Water District	
City of Bakersfield Water Resources	43,211	Mountain Mesa Water Company	
City of Delano	9,271	North of the River Municipal Water District	8,400
City of Maricopa		Oildale Mutual Water Company	7,148
City of McFarland	1,765	Rainbird Valley Mutual Utility Company	
City of Shafter	4,735	Stallion Springs Community Services District	399
City of Tehachapi	2,043	Tejon-Castac Water District	1,587
City of Wasco	4,681	Valley Estates Property Owners Association	
East Niles Community Services District	8,962	West Kern Water District	24,729
Frazier Park Public Utility District	1,768	Stockdale Mutual Water Company and Annex	219
Golden Hills Community Services District	1,210	Victory Mutual Water Company	205
Greenfield County Water District	2,843	Vaughn Water Company	11,104

\* 2010 water use is obtained from data contained in 2010 Urban Water Management Plans or the 2011 Kern IRWMP.

Table 2-5. Non-Potable Water Suppliers within the Kern SWRP

Non-Potable Water Suppliers within the Kern SWRP			
Water District	Data Source	Irrigated Acres	Total Crop Water Demand (AF)
Arvin-Edison Water Storage District	2011 WMP	112,617	325,024
Belridge Water Storage District	2015 AWMP (2014 Data)	37,185	138,757
Berrenda Mesa Water District	2015 AWMP (2014 Data)	24,836	85,003
Buena Vista Water Storage District	2015 AWMP (2015 Data)	32,437	96,886
Cawelo Water District	2016 AWMP (2015 Data)	33,630	114,816
Delano- Earlimart Irrigation District	2012 WMP (2008 Data)	49,149	158,320
Dudley Ridge Water District	2015 AWMP (2015 Data)	16,622	62,527
Henry Miller Water District	Kern IRWMP (2005 Data)	18,876	47,000
Kern Delta Water District	2015 AWMP (2013 Data)	91,530	297,260
Kern Tulare Water District	2016 AWMP (2015 Data)	18,157	61,514
Lost Hills Water District	2015 AWMP (2014 Data)	30,435	112,048
North Kern Water District	2015 AWMP (2014 Data)	57,393	185,603
Rosedale Rio Bravo Water Storage District	2014 Operations Report (2014 Data)	29,000	87,465
Semitropic Water Storage District	2015 AWMP (2015 Data)	135,996	388,120
Shafter-Wasco Irrigation District	2011 WMP (2011 Data)	30,127	101,026
Tehachapi-Cummings County Water District	Kern IRWMP (2005 Data)	3,393	8,449
Wheeler Ridge Maricopa Water Storage District	2015 AWMP (2015 Data)	85,973	219,595
Olcese Water District	Kern IRWMP (2005 Data)	2,008	5,000

Figure 7 shows non-potable water distribution and flood water capture infrastructure for the region. Proposed projects described and ranked in Section 5 will rely on this infrastructure as a means of improving groundwater recharge capacity through the capture of storm water and dry weather run-off in the Kern Region.

## 2.6 Native Habitat, Water Bodies, and Open Space

Kern County’s remaining native land is primarily semi-desert and desert landscape with varying geology and wildlife with rivers and creeks. There are a number of state and federally protected areas; including river habitat areas, parks, and wildlife refuges.

Geologically, the Kern Region is located in four of the twelve traditionally recognized geomorphic provinces in California, including the Coast Ranges, the Great Valley, the Transverse Range, and the



Sierra Nevada Range province. These geologic attributes influence the climate, wildlife, vegetation, hydrology, and other environmental factors in the Region. Notably within the Coast Range is the San Andreas Fault.

The Tulare Lake Basin has two outlets for surface waters (North Fork of Kings River and Kern River-Aqueduct Intertie). These are only used in very wet years as outlets to prevent flooding of lands in low lying areas. Streams from the Sierra Nevada, Coast Ranges and Tehachapi Mountains have eroded and deposited materials in the Tulare Lake Basin, forming alluvial fans at the surface.

Environmental resources of the Region include the Kern River, Sequoia National Forest, several wildlife refuges, and the unique flora and fauna of the Tejon Pass area and Transverse Ranges. The riparian forest along the South Fork Kern River is one of the highest quality and most extensive stands of that vegetation type in California. Much of this forest is conserved in the U.S. Forest Service (USFS) South Fork Wildlife Area, Audubon California's Kern River Preserve, and California Department of Fish & Wildlife's (CDFW) Canebrake Ecological Reserve.

The Kern River pools at Isabella Reservoir behind Isabella Dam, which is a U.S. Army Corps of Engineers (USACE) flood control facility protecting the City of Bakersfield and other downstream areas. After leaving Isabella Reservoir the river travels generally southwest through the Sierra foothills and the City of Bakersfield. The Kern River supports many vegetation types and both common and sensitive species are found along the river corridor.

The Sequoia National Forest draws visitors from around the world, primarily attracted by the giant sequoia trees. In addition to the giant sequoia, the forest is home to numerous animals, including several rare and endangered species.

The 1,249-acre Kern National Wildlife Refuge contains remnant habitats of the original Tulare Lake region and consists of freshwater marshes, valley grasslands, and a relict cottonwood-willow riparian corridor. The refuge provides habitat for wintering and migrating waterfowl, shorebirds, and marsh birds and also provides habitat for upland and riparian bird species.

The Bitter Creek National Wildlife Refuge is located in the southwest corner of the region. This refuge is intended to protect dwindling California condor foraging and roosting habitat. The refuge is bisected by the San Andreas Fault and Bitter Creek Canyon. In addition to the California condor, there are numerous other animals and bird species found in the refuge.

The southeastern portion of the region, surrounding the Tejon Pass area, is the intersection of five geomorphic provinces: Sierra Nevada, Great Central Valley, Coast Ranges, Transverse Ranges, and Mojave Desert. These geomorphic areas each have a distinct ecology, and the intermixing of these geomorphic provinces creates a unique and diverse landscape in a relatively small area. Because of its unique biogeography and location between major urban centers in Los Angeles and Kern counties, the Tejon Pass area also supports many threatened and endangered species and other species considered rare or sensitive because of their restricted distributions and substantial loss of habitat. At least 20 species listed as Threatened or Endangered under the Federal and California Endangered Species Acts and an additional 61 species otherwise designated as sensitive are known to occur or have the potential to occur in the vicinity of Tejon Pass.

In 2008, five environmental organizations and the Tejon Ranch Company entered into an agreement to permanently protect 178,000 acres of Tejon Ranch in the southern area of the region, near the community of Lebec. The Tejon Ranch Conservancy, an independent nonprofit conservation organization will monitor and enforce a conservation easement on the 178,000 acres of conserved lands while implementing a long-term stewardship plan to protect and restore habitat. The Tejon Ranch Conservancy is working to acquire an additional 62,000 acres. The majority of the preserve is in Kern County with a portion in Los Angeles County (Tejon Ranch Conservancy 2009).

Since 1998, The Wildlands Conservancy has owned and managed Wind Wolves Preserve, an ecologically unique region where the Transverse Ranges, Coast Ranges, and San Joaquin Valley converge. Due to elevation ranging from 640 to 6,005 feet, and 95,000 acres, the preserve has an impressive array of landforms and habitats that serve as a critical landscape linkage and wildlife corridor between the Coast Ranges and Sierra Nevada.

## 2.7 Natural Watershed Process Interruptions

Before development by European immigrants, the watershed process was mostly uninhibited and surface water flowed unimpaired from the Sierra Nevada Mountain Range into the San Joaquin Valley via the Kern River and other smaller tributary streams and creeks. Low lying areas in the Kern and Buena Vista Lake beds were flooded by the river and its associated sloughs. As immigrant communities were developed, surface flows were diverted to support the urban population bases via dams, canals, and pipelines. Before development, the valley floor's land was mostly pervious (with the exception of rock outcroppings, swamp, overflow lands, and lake bottoms) and allowed storm/rainfall infiltration. Presently, the urban areas have large impervious areas reducing infiltration (thereby reducing groundwater recharge from rainfall).

Surface waters from the Kern River were dammed at Lake Isabella (northeast of Bakersfield) to provide flood protection, hydroelectric power, and water supply.

Through continued urban growth and the demand for water, groundwater wells have been used to supplement the limited surface water supply. Even with surface water importation, demands for critical water resources, including from environmental protection actions, have outstripped supplies. Groundwater levels have dropped and have been listed by DWR as being in a state of critical overdraft.

The Kern IRWMP (Table 2-20) identified crops within Kern County (see **Table 2-6** below). The annual crop water demand is shown below. Note that the estimate of crop water demands in the Region are being updated through the Kern Groundwater Authority under a study being prepared by the Irrigation Training and Research Center (ITRC) using processed satellite imagery. Once this information is made available, the crop water demands in this table will be updated in a future revision of this Plan.

Table 2-6. Kern IRWMP Table 2-20, Summary of Agricultural Water Demand (AFY)

Kern IRWMP Table 2-20, Summary of Agricultural Water Demand (AFY)			
Crop Type	Irrigated Acreage	Consumptive Water Use (AF/acre)	Agricultural Water Demand (AFY)*
Alfalfa (including seed)	92,210	4.10	378,000
Almonds	179,948	3.28	590,000
Apples, Pears, Plums	3,178	3.45	11,000
Apricots, Nectarines, Peaches	4,642	3.35	16,000
Beans	3,712	2.11	8,000
Carrots	28,645	2.55	73,000
Citrus	57,904	3.37	195,000
Corn, Grain Sorghum	52,008	2.95	153,000
Cotton	74,212	2.71	201,000
Grapes	101,571	2.81	285,000
Grain and Grain Hay	58,647	2.07	121,000
Idle, Fallow Lands	183,495	0.33	60,000
Melons, Squash, Cucumbers	4,208	1.46	6,000
Misc. Deciduous Trees	18,433	3.34	62,000
Misc. Field Crops	664	2.09	1,000
Misc. Subtropical Trees	4,123	3.38	14,000
Misc. Vegetables	11,759	1.62	19,000
Nursery	5,000	3.28	16,000
Onions, Garlic	6,982	1.70	12,000
Pasture, Turf, Misc. Grasses	9,136	4.13	38,000
Pistachios	78,528	4.11	322,000
Potatoes	17,466	1.98	35,000
Safflower, Sunflower	2,068	2.23	5,000
Sugar Beets	489	3.29	2,000
Tomatoes	15,802	2.51	40,000
Turnips	209	1.62	500
Walnuts	1,907	3.89	7,000
<b>Total Irrigated Lands:</b>	<b>833,452</b>	<b>2.49</b>	<b>2,670,000</b>
<b>Total Crop Lands:</b>	<b>1,016,946</b>		

Kern IRWMP, November 2011. Data is from 2007.

\*Water Demand rounded to nearest 1,000 AFY.

Other natural watershed interruptions include transportation infrastructure including vehicle and railroad corridors. These corridors (infrastructure) are additional impervious surfaces and locations where previously free flowing surface waters are engineered into localized paths to protect railways or roadways.

## 3 Compliance with Water Quality Standards

Storm Water Resource Plans must comply with applicable water quality provisions developed and implemented by the U.S. Environmental Protection Agency (EPA), SWRCB, CVRWQCB and takes into consideration the concerns and needs of local agencies and constituents. These agencies are tasked with oversight, permitting, enforcement, and monitoring. Sources of pollution can include NPS such as runoff from developed areas, agricultural farmland, confined animal units, and/or grazing areas. Contaminants from these sources are often naturally occurring in rocks and soil, including minerals; heavy metals such as arsenic, chromium and selenium; and nutrients.

Additionally, the Kern Region has local water quality regulations and policies related to the Kern River, Cross Valley Canal, Friant-Kern Canal, and the California Aqueduct that must be considered.

### 3.1 Compliance Requirements for Plan Implementation

Pollution can originate from point-sources where pollutants are directly discharged to waterways from operations such as wastewater treatment facilities, industries, and dairies. Point source pollutants are typically covered by Waste Discharge Requirements (WDR) and National Pollutant Discharge Elimination System (NPDES). NPS pollution prevention utilizes best management practices (BMPs), efficient water management practices, and source control.

The Federal CWA focuses on two elements for protecting water quality. These include a technology-based approach that uses requirements to maintain a minimum level of pollutant management using the best available technology and a water quality-based approach that relies on evaluating the condition of surface waters and setting limitations on the amount of pollution that the water can be exposed to without adversely affecting the beneficial uses of those waters. Section 303(d) of the CWA incorporates these two strategies.

Section 303(d) requires that the state make a list of waters that are not attaining standards after the technology-based limits are put into place. For waters on this list, as deemed appropriate by the EPA, the state is required to determine all the sources of the constituents of concern including those from point sources and NPS. The only water body on the 303(d) list within Kern Region is Isabella Reservoir, which has two constituents listed (pH and dissolved oxygen). Isabella Reservoir regulates flows for the Kern River, and is a recreational facility. The Kern River is not listed on the 303(d) list, and generally has excellent water quality. Periodically, localized areas of the river can have water quality concerns, such as increased sediment loading of the river after forest fires, which can significantly affect its watershed.

In addition to the Federal CWA, the State Porter-Cologne Water Quality Control Act required water quality control plans to be established for water quality standards to protect the beneficial uses of water sources. The CVRWQCB established and adopted the Water Quality Control Plan for the Tulare Lake Basin (Basin Plan). The Basin Plan lists the designated beneficial uses to be protected, water quality objectives to protect those uses, and an implementation program for achieving the objectives. The Basin Plan serves as a regulatory reference for meeting both state and federal requirements for surface and groundwater water quality control in the Tulare Lake Basin. The CVRWQCB regulates discharges to both surface water and groundwater in a variety of ways to

protect water quality to standards related to the designated beneficial uses. Point source waste discharges are generally regulated by Point of Treatment Wastewater Discharge Requirements that includes treatment standards, monitoring, and reporting. The CVRWQCB also has several water quality protection programs related to discharges from NPS. These include the Dairy General Order and Irrigated Lands Regulatory Program (ILRP). There are numerous water quality regulations associated with these NPS programs.

The CVRWQCB has been working with stakeholders through the Central Valley Salinity Alternatives for Long-term Sustainability (CV-SALTS) Program to develop amendments to the basin plans in California's Central Valley, including the Tulare Lake Basin, related to salts and nitrates in surface and groundwater. These amendments are expected to occur within the next few years, and establish processes for exempting agricultural dominated water bodies from "default" drinking water protection, as well as more localized standards for salinity and nitrate degradation.

### 3.1.1 CEQA Compliance

Storm water related projects proposed for the study area by public agencies must comply with the California Environmental Quality Act (CEQA). The CEQA process includes work to identify any potential negative impacts that may be associated with implementing the submitted projects include (1) short-term, site specific impacts related to site grading and construction, (2) long-term impacts associated with project operation, and (3) cumulative impacts associated with project construction and/or operation when considered together with other known projects or programs.

The CEQA process will evaluate the significance of any potential impacts. CEQA requires that any impacts determined to be significant must be mitigated to a level of non-significance (unless the CEQA lead agency makes findings of overriding consideration in an environmental impact report (EIR) that reviews the project and options to it).

CEQA review of specific projects will provide a detailed evaluation of the potential impacts discussed below:

- **Aesthetics** – Projects that include construction activities and new infrastructure have the potential to affect aesthetics. However, it is likely that projects would be constructed in areas that are already disturbed, or would include mitigation measures that would return disturbed areas to their pre-construction conditions.
- **Air Quality** – Short-term air quality impacts could result from construction of the projects. However, through the CEQA process potential air emissions would be minimized through application of BMPs identified by the air quality management district or mitigation measures.
- **Biological Resources** – Short-term and long-term biological impacts could result from construction activities as well as non-native plant removal. Most of these negative effects would be avoided or minimized through mitigation efforts related to CEQA. Some projects could result in overall benefits to biological resources.
- **Cultural Resources** – Impacts to cultural resources (historical, archeological, and paleontological resources) could result from construction activities from the projects. As part of the CEQA process it will be necessary to develop mitigation measures to avoid or minimize these potential impacts.

- **Geology and Soils** – Projects with the potential to impact geologic resources would be required to undergo geological feasibility studies which would specify the appropriate engineering standards the contractor would have to comply with during construction. Compliance with these standards would mitigate project site geological and soil impacts.
- **Hydrology and Water Quality** – It is anticipated that impacts to hydrology and water quality would be generally beneficial because in the long-term projects are intended to improve water supply reliability and water quality. For short-term erosion or sedimentation, project-specific BMPs would be identified as part of the NPDES permitting process.
- **Land Use and Planning** – Projects are evaluated as to their compatibility with other planning documents for the Kern Region, including local and regional General Plans. No significant land use changes or inconsistencies with policies are anticipated though.
- **Noise** – Noise impacts could result from construction activities from some of the proposed projects. However, through the CEQA process most of these activities would be minimized through mitigation efforts and no long-term noise impacts are expected.
- **Population and Housing** – No adverse impacts to population and housing are anticipated. Project implementation would help to meet the water demands of the existing and anticipated future population.
- **Public Services and Utilities** – Many of the projects are intended to enhance water supply, water quality, and improve storm water management and flood control. These types of projects would benefit the utilities and service systems in the Kern Region.
- **Recreation** – Projects are anticipated to improve or have no impact on recreational activities within the County.
- **Transportation and Circulation** – Transportation and circulation could be temporarily impacted during construction of some of the projects. Construction can temporarily increase traffic congestion due to transportation of equipment and trips by workers. Construction of projects located near roadways can result in temporary lane closures and detours. However, through the CEQA process most of these activities would be avoided or minimized and no long-term transportation and circulation impacts are expected.

### 3.1.2 California Health and Safety Code

The California Health and Safety Code includes provisions for the control of vectors including mosquito abatement. The Mosquito Abatement Act of 1915 allows municipalities and counties to create Mosquito Abatement Districts. The risks of mosquitoes due to delinquent water handling practices include marsh, malaria, encephalitis and West Nile virus. Proper BMPs can significantly reduce mosquito populations and their associated illnesses.

Projects performed in accordance with this Plan must adhere to the requirements of the local mosquito abatement districts. The Kern Mosquito and Vector Control District, Kern County Environmental Health Services, Delano Mosquito Abatement District, West Side Mosquito and Vector Control District, and South Fork Mosquito Control District provide mosquito abatement services within Kern Region, depending upon location.

BMPs established by the applicable mosquito abatement district must be implemented for all projects included in this Plan. BMPs include source reduction including the elimination, reduction or modification of larval habitats, biological control such as using predators to reduce larval population, and mosquitocides including larvicides and adulticides.

### 3.1.3 Water Rights

Groundwater recharge is the augmentation of groundwater, by natural or artificial means, with surface water or recycled water. Groundwater recharge is not a beneficial use of water in and of itself. Some groundwater recharge projects may be based on short-term water surpluses that occur infrequently, assuming that water is available for appropriation. A diversion to underground storage can be a method of diverting water, taking advantage of the natural storage capacity of aquifers; however to obtain a water right, there must be a designated beneficial use of the water placed to underground storage. Groundwater storage projects have been successfully constructed and are operating in California, with diversion to underground storage being the method of diversion. These projects include the use of the stored water for beneficial use, just as with surface water storage projects. The beneficial uses, including the extraction of the stored water, are required to be protective of water quality.

Water rights are required to capture stream flows, including peak storm events, for groundwater recharge with later beneficial use. Except where the storage and beneficial use are authorized under an existing appropriative right, or a change in that right, this will require filing an application with the SWRCB to obtain a water rights permit. In the water rights application, beneficial uses (i.e., municipal, irrigation, municipal, industrial, water quality, etc.) of the water placed to underground storage will need to be specified.

Consideration of project operation timelines and approval requirements will dictate the need for a standard permit or temporary permit. An application for a standard permit should be filed for proposed long-term projects. A temporary permit should be filed for projects of a temporary nature where an urgent need exists. Assuming there is an urgent need, an application for a temporary permit may be filed simultaneously with an application for a standard permit, to cover the period until a standard long-term permit is issued. Temporary permits expire within 180 days after the date of issuance, unless specified. Temporary permits may be renewed by the SWRCB. Both permits require detailed reporting of the amount of water diverted into underground storage and the amount removed for beneficial use.

- **Standard Permit** – A standard permit development timeline is 15 years, however for groundwater a longer development period may be warranted.
- **Temporary Permits** – No development period is specified, but permittee must report on beneficial use of the diverted water. For these types of projects, the permittee will need to file temporary permit renewals until the amount beneficially used is equivalent to the diversion amount.

Projects that are not required to apply for a permit include projects that meet the following criteria:

- Projects designed and used solely for flood protection and not for beneficial use; where capture of flood waters is necessary to protect health and safety, and is not intended to store the water for later beneficial use by any party. This assumes that the water is held no longer

than needed for flood control and that no right is asserted to any of the groundwater recharge that results from the flood control.

- Projects that propose to replenish groundwater with recycled water, where the recycled water comes directly from a water treatment plant and is not conveyed using a surface water stream system or a subterranean stream. In this situation, a wastewater change petition may be necessary if the wastewater was previously discharged to a stream.
- Projects diverting water under a valid pre-1914 appropriative right.
- Projects that use water delivered under a water supply contract or purchase agreement in which the water purveyor delivering the water has a right to divert water to underground storage at the proposed location.

### 3.1.4 Local Water Quality

Surface water supplies in the area provide water for crop cultivation, municipal supplies and groundwater banking. Major surface water conveyances in the Region include the California Aqueduct, the Friant-Kern Canal, the Kern River, Poso Creek and the Cross Valley Canal (CVC).

#### 3.1.4.1 Friant-Kern Canal

The USBR operates the CVP and its associated conveyance canals including the Friant-Kern Canal, and jointly operate the San Luis Canal/California Aqueduct together with DWR to the Kern County line. Non-CVP water conveyed in the Friant-Kern Canal requires a Warren Act contract and must comply with water quality standards set by the USBR.

The current non-emergency non-CVP water quality regulations are being revised. The current standards protect the Friant-Kern Canal to drinking water quality standards. Modifying this to include agricultural water quality standards has been discussed.

Agencies located near the end of the Friant-Kern Canal are the most impacted by water quality issues due to the conveyance of non-CVP water in the canal. Temporary water quality exchange agreements have been developed as part of some water banking and exchange programs to allow them to move forward on a short term basis.

#### 3.1.4.2 California Aqueduct

DWR conveys local groundwater using the SWP conveyance structures through Pump-In Projects. These projects operate in accordance with the California Water Code which states that non-project water may be conveyed, wheeled, or transferred in the SWP provided that water quality is protected. The acceptance of Pump-In water is through established agreements with DWR's State Water Project Analysis Office (SWPAO).

These agreements between SWPAO and Pump-In entities include water quality criteria among other aspects. These water quality criteria dictate that a Pump-In entity of any non-project water program must demonstrate that the water is of consistent, predictable, and acceptable quality prior to pumping the local groundwater into the SWP. Since there cannot be any adverse impacts to SWP water deliveries, operations or facilities, the water quality criteria cannot constrain DWR's ability to operate the SWP for its intended purposes or to protect its integrity during emergencies.



The Pump-In volumes and water quality are monitored regularly when the Pump-In entities are introducing local groundwater into the SWP. Agencies participating in the Pump-In Projects in recent years include:

- Westlands Water District
- San Luis Water District
- Semitropic Water Storage District
- Kern County Water Agency for Cross Valley Canal users
- Kern Water Bank Authority for users of Kern Water Bank Canal
- Buena Vista Water Storage District
- Arvin-Edison Water Storage District
- Wheeler Ridge-Maricopa Water Storage District

#### 3.1.4.3 Kern River

Water discharges to the Kern River are regulated by the CVRWQCB. Storm water discharges that have the potential to affect Kern River water quality are subject to review by the Kern River Water Master and Kern River water users. Kern River water users meet periodically when issues warrant it.

#### 3.1.4.4 Poso Creek

Poso Creek diversions are governed by an agreement between North Kern, Cawelo and Semitropic, who share the runoff from the creek. Under the agreement, riparian users have first right to the water. Once these are satisfied, the water is shared among the three agencies in accordance with the following guidelines based on the flow measured in Poso Creek at Highway 65:

- Cawelo – Less than 135 cfs
- North Kern – Between 135 cfs and 300 cfs and greater than 685 cfs
- Semitropic – Between 300 cfs and 685 cfs

Total dissolved solids (TDS) concentrations in Poso Creek are typically higher than the Kern River, but less than SWP water. Discharges to Poso Creek are regulated by the CVRWQCB.

#### 3.1.4.5 Cross Valley Canal

The Cross Valley Canal (CVC) is operated by the KCWA for the agencies that hold Cross Valley contracts for water from the Delta through the USBR and for other agencies that own CVC capacity (which is used to move water across the valley). The Cross Valley Canal Advisory Committee (CVCAC) represents those agencies.

Formal water quality guidelines for the CVC have not been developed, however, during the environmental review process, storm water projects that have the potential to alter the water quality of the CVC would be subject to the review and approval of the KCWA and the CVCAC.

## 3.2 Proposed Modification(s) of an Existing Stream Bed or Channel

Projects within the Plan that include substantial change or use of any material from a river, stream, or lake should avoid and minimize erosion, sediment transport, and hydromodification, and fully mitigate environmental impacts resulting from the project as required by Clean Water Act sections 401 and 404 and any other federal and state laws, regulations and permits. If a stream bed modification is identified in the project, a complete notification package and fee must be submitted to the California Department of Fish and Wildlife (CDFW) regional office that serves the county where the activity will take place.

The CDFW Code section 1602 requires an entity to notify CDFW prior to commencing any activity that may do one or more of the following:

- Substantially divert or obstruct the natural flow of any river, stream or lake.
- Substantially change or use any material from the bed, channel or bank of any river, stream, or lake.
- Deposit debris, waste or other materials that could pass into any river, stream or lake.

"Any river, stream or lake" includes those that are episodic (dry for periods of time) as well as those that are perennial (flow year round). This includes ephemeral streams, desert washes, and watercourses with a subsurface flow. It may also apply to work undertaken within the flood plain of a body of water.

## 3.3 Monitoring Plan Requirements

### 3.3.1 Data Collection

Statistically meaningful data will be collected from projects implemented in accordance with this Plan when relevant. The frequency and method of sampling and data collection will be dependent upon the nature of the project, but will be reviewed to ensure that the Project meets local, state and federal requirements. Monitoring and reporting efforts associated with this plan will not duplicate monitoring efforts undertaken by other agencies. Data will be integrated with other datasets and will be updated annually.

Data collection and analysis can help to quickly identify data gaps, assess project and program performance, support statewide data needs, and integrate datasets with other regional and statewide programs. Within the plan boundary, there are a several entities collecting and maintaining data on the Region's water and environmental resources.

KCWA collects data on groundwater and surface water supplies and water quality. Since its formation in 1961, KCWA, or through other water districts, has collected information on the water supply and demand characteristics of the San Joaquin Valley portion of Kern County. Since 1977, the Agency has published its annual Water Supply Report to present these statistics in one document and to assist water leaders and users in making water management decisions.

The Kern River interests are valley floor entities with Kern River rights; they include: Buena Vista Water Storage District (WSD), Kern Delta Water District, North Kern WSD, City of Bakersfield and KCWA. More specifically, North Kern WSD, Kern Delta WSD, and the City of Bakersfield have rights below the “first point of measurement,” Buena Vista WSD has “second point of measurement” rights and the KCWA has lower river (a.k.a. high flow) rights. The Kern River Interests collectively have hired a Watermaster to maintain records for the first point of measurement. Buena Vista WSD also is responsible for the collection and maintenance of second point records.

The Kern Fan Monitoring Committee (KFMC) was established through various MOUs among the Kern Fan area entities. The members of the Committee include both banking project participants and adjoining entities (those entities whose lands and/or banking projects are adjacent to the banking projects). The KFMC is responsible for collecting data from participants/adjoining entities and reporting that data in the KFMC’s “Kern Fan Area Operations and Monitoring Report.” Other activities/authorities of the committee include: hiring technical consultants, determining the need for/placement of additional monitoring sites and dispute resolution. Data that is collected and published in the Operations and Monitoring Report includes groundwater levels, groundwater elevation and water quality sampling results. Entities involved in banking programs such as the Kern Water Bank collect annual statistical data in accordance with the MOUs, and in some cases groundwater management plans of local agencies prepared under Assembly Bill (AB) 3030 (the Groundwater Management Planning Act, and other groundwater law provisions).

Each of the agencies and agency groups are collecting data that is important to the Region, have methods for data collection that are similar, and thus have opportunities for streamlining or maximizing efficiencies for creating region-wide datasets and databanks. Data is vitally important to agencies trying to maximize operating efficiency and design projects with limited budgets. The types of data available, current relevance and trends, and knowledgeable people that can interpret the data are all important. Monitoring associated with Plan implementation is an opportunity for state agencies to obtain data for their own monitoring needs and to better understand local conditions. Creation of data management tools that recognize similarities in methodology, the repetitiveness in data harnessing, and inefficiencies in data reporting are additional strategies that can be implemented in order to streamline efforts on not just a local, but a region-wide scale as well. The ongoing data collection and management efforts for the Plan will establish a means to collect and maintain the data. Additionally, data gaps will be reviewed and discussed with member agencies to determine an appropriate method for rectifying the gaps.

### 3.3.2 Integration into Existing Monitoring Efforts

Data collected as part of this Plan can be used to support existing state programs such as the Surface Water Ambient Monitoring Program (SWAMP), the Groundwater Ambient Monitoring and Assessment (GAMA), and the California Environmental Resources Evaluation System (CERES), as well as water use efficiency and demand reduction data collected by the SWRCB through the California Urban Water Conservation Council (CUWCC) and Ag Water Management Council (AWMC). A brief description of each program is listed below:

- **Surface Water Ambient Monitoring Program (SWAMP)** – All the surface water data collected as part of projects implemented through grant funding will be consistent with

SWAMP database compatibility guidelines, and will be exported annually to the state database using the required data submission formats.

- **Groundwater Ambient Monitoring and Assessment (GAMA)** – As required by grant programs that implement Kern SWRP projects, groundwater data collection efforts will be coordinated with the needs of the GAMA program and will be consistent with database specifications so that the data can be easily submitted, shared, and integrated into the GAMA database. Field sampling efforts will be coordinated with the GAMA program to eliminate duplicative data collection efforts and fill data gaps.
- **California Environmental Resources Evaluation System (CERES)** – As required by a grant programs that implement Kern SWRP projects, data and reports will be sent to CERES so that information will be available and useful to a wide variety of users.
- **California Statewide Groundwater Elevation Monitoring (CASGEM)** – On November 4, 2009 the State Legislature enacted SBX7-6, which mandates a permanent statewide, locally-managed groundwater elevation monitoring program for California’s groundwater basins and sub-basins identified in DWR Bulletin 118. To achieve that goal, the new law directs that groundwater elevations be regularly and systematically monitored, and groundwater elevation data collected under collaboration between local monitoring entities and DWR. The primary objective of the CASGEM monitoring program is to define the seasonal and long-term trends in groundwater elevations in California’s groundwater basins. The scale for this evaluation should be the static regional groundwater table or potentiometric surface. A secondary objective is to provide sufficient data to draw representative contour maps of the elevations. These maps could be used to estimate changes in groundwater storage and to evaluate potential areas of overdraft and subsidence.

### 3.3.3 Multiple Separate Storm Sewer System (MS4) Projects

The Municipal Storm Water Permitting Program regulates storm water discharges from municipal separate storm sewer systems (MS4). Storm water is runoff from rain or snow melt that runs off surfaces such as rooftops, paved streets, highways or parking lots and can carry with it pollutants such as: oil, pesticides, herbicides, sediment, trash, bacteria and metals. The runoff can then drain directly into a local stream, or other water body. Often, in the Kern Region, the runoff drains into storm drains which eventually drain untreated into local storm water retention basins.

Additionally, municipal or urban areas commonly include large impervious surfaces which contribute to an increase in runoff flow, velocity and volume. As a result streams are hydrologically impacted through streambed and channel scouring, instream sedimentation and loss of aquatic and riparian habitat. In addition to hydrological impacts, large impervious surfaces contribute to greater pollutant loading, resulting in turbid water, nutrient enrichment, bacterial contamination, and increased temperature and trash.

MS4 permits were issued in two phases.

Under Phase I, which started in 1990, the Regional Water Quality Control Boards adopted National Pollutant Discharge Elimination System General Permit for storm water permits for medium (serving between 100,000 and 250,000 people) and large (serving 250,000 people) municipalities.

Most of these permits are issued to a group of co-permittees encompassing an entire metropolitan area. These permits are reissued as the permits expire. The Phase I MS4 permits require the discharger to develop and implement a Storm Water Management Plan/Program with the goal of reducing the discharge of pollutants to the maximum extent practicable (MEP). MEP is the performance standard specified in Section 402(p) of the Clean Water Act. The management programs specify what BMPs will be used to address certain program areas. The program areas include public education and outreach; illicit discharge detection and elimination; construction and post-construction; and good housekeeping for municipal operations. In general, medium and large municipalities are required to conduct monitoring.

On April 30, 2003, as part of Phase II, the State Water Resources Control Board issued a General Permit for the Discharge of Storm Water from Small MS4s (WQ Order No. 2003-0005-DWQ) to provide permit coverage for smaller municipalities (population less than 100,000), including non-traditional Small MS4s, which are facilities such as military bases, public campuses, prison and hospital complexes. The Phase II Small MS4 General Permit covers Phase II Permittees statewide. On February 5, 2013 the Phase II Small MS4 General Permit was adopted and became effective on July 1, 2013.

Within the SWRP boundary there is one Phase I permittee; the City of Bakersfield and Kern County have a joint cooperative permit. **Table 3-1** below lists the Phase II Traditional and Non-Traditional permittees.

**Table 3-1. Phase II Traditional and Non-Traditional Permittees**

Phase II Traditional and Non-Traditional Permittees	
Traditional Permittees	Non-Traditional Permittees
City of Delano	CSU Bakersfield
City of Ridgecrest	Kern County Fairgrounds
City of Tehachapi	
City of Wasco	

Monitoring programs are specific to each MS4 program, however the Phase II permittees are bound by prescriptive requirements within Water Quality (WQ) Order No. 2003-0005-DWQ. Water quality data is stored at the state level through various reporting program requirements such as CASGEM, Urban Water Management Planning Act, Sustainable Water Use and Demand Reduction requirements, and other monitoring/reporting included in **Section 3.3.2**.

# 4 Organization, Coordination and Collaboration

## 4.1 Introduction and Overview

This section identifies the local agencies and nongovernmental agencies that have been consulted in the development of this Storm Water Resource Plan, as well as those who will be included in the implementation of the Plan, and describes the process of communication. Key stakeholders include members of the Kern and Poso Creek Integrated Regional Water Management Plan groups, many of whom have a long-standing history of coordination and collaboration regarding Kern County water resources.

During Plan development, the primary focus of these agencies was to make certain that local, regional, and watershed-wide obstacles are addressed in order to maximize benefits and ultimately enhance water conservation efforts within the Kern Region. In addition, the relationship between storm water resource projects noted in this Plan, and other IRWMPs and planning documents, and their affects on disadvantaged communities (DAC) are discussed.

## 4.2 Regional Water Management Groups Implementing Existing IRWM Plans

The Kern SWRP benefits the entities of the Kern and Poso Creek IRWM Regional Water Management Groups, and their existing IRWMPs. IRWMP boundaries are defined on the IRWMP Boundary Map ([Figure 1](#)).

### 4.2.1 Overview of Kern IRWMP

The Kern Regional Water Management Group was established in October 2008, and represents the Tulare Lake Basin portion of Kern County. The group is a collaboration of water suppliers, community and government representatives, environmental groups, businesses, and other interested parties. The IRWMP seeks to preserve the economic and environmental health of Kern County communities through comprehensive and efficient management of its water resources. Members of the Kern RWMG are listed in [Table 4-1](#).

### 4.2.2 Overview of Poso Creek IRWMP

The Poso Creek Regional Water Management Group formed in 2005, and consists of a group of individual water management districts and agencies in the northern Kern County and southern portion of Tulare County. The Poso Creek IRWMP was originally written and adopted in 2007 to provide the framework for coordinating groundwater and surface water management activities through regional objectives, and for implementing the measures necessary to meet those objectives. The IRWMP was updated in 2014 to reflect the IRWM Group's expanded planning efforts to

address Department of Water Resources’ Proposition 84 guidelines. Members of the Poso Creek RWMG are listed in **Table 4-1**.

## 4.3 Stakeholder Agencies that Participated in Plan Development

### 4.3.1 Stakeholder Agencies

The stakeholder agencies that were invited to participate in the development of the Storm Water Resource Plan include members of the Kern IRWM and Poso Creek IRWM Regional Water Management Groups (RWMG). These agencies and organizations were given an opportunity to participate and exercise their authorities and mandates in order to address the SWRCB’s storm water and dry weather management objectives which are required for the Plan. These stakeholders are listed in **Table 4-1**:

**Table 4-1. Stakeholder Agencies and Organizations**

Stakeholder Agencies and Organizations	
<b>Kern IRWM</b>	
Arvin Community Services District	Kern Delta Water District
Arvin-Edison Water Storage District	Kern Water Bank Authority
Bear Valley Community Services District	Lamont Public Utility District
Belridge Water Storage District	Lamont Stormwater Utility District
Berrenda Mesa Water District	Lebec County Water District
Buena Vista Water Storage District*	Long Canyon Water Company
Buttonwillow County Water District	Lost Hills Utility District*
California Water Service (Bakersfield, Lake Isabella)	Lost Hills Water District*
Canyon Meadows Mutual Water Company	Mettler County Water District
Casa Loma Water Company	Mountain Mesa Water Company
City of Arvin	North of the River Municipal Water District
City of Bakersfield (Water Resources)	North West Kern Resource Conservation District*
City of Delano*	Oildale Mutual Water Company
City of Maricopa	Olcese Water District
City of McFarland*	Rainbird Valley Mutual Utility Company
City of Shafter*	Rosedale-Rio Bravo Water Storage District*
City of Taft	South San Joaquin Municipal Utility District*
City of Tehachapi	Southern California Edison
City of Wasco*	Stallion Springs Community Services District
County of Kern – Resource Management Agency*	Tehachapi-Cummings County Water District
Desert Mountain Resource Conservation and Development Council	Tehachapi Resource Conservation District
Dudley Ridge Water District	Tejon-Castac Water District
East Niles Community Services District	Tubatulabals of Kern Valley
Frazier Park Public Utility District	Tulare Basin Wildlife Partners
Golden Hills Community Services District	Valley Estates Property Owners Association

Stakeholder Agencies and Organizations	
Greenfield County Water District	Vaughn Water Company
Henry Miller Water District	West Kern Water District
Improvement District No. 4	Westside Mutual Water Company
Kern County Water Agency*	Wheeler Ridge-Maricopa Water Storage District
<b>Poso Creek IRWM</b>	
Bishop Acres Mutual Water Company	Friant Water Users Authority
Buena Vista Water Storage District*	Kern County Water Agency*
Cawelo Water District	Kern National Wildlife Improvement District
City of Buttonwillow	Kern-Tulare Water District
City of Delano*	Lost Hills Utility District*
City of McFarland*	Lost Hills Water District*
City of Shafter*	Maple Elementary School
City of Wasco*	Pond Union School District
Community of Allensworth	North Kern Water Storage District
Community of Blackwells Corner	North West Kern Resource Conservation District*
Community of Earlimart	Rodriguez Farm Labor Camp
Community of Lost Hills	Rosedale-Rio Bravo Water Storage District*
Community of Madonna	Semitropic Water Storage District
Community of North Shafter	Semitropic Wildlife Improvement District
Community of Pond	Shafter-Wasco Irrigation District
Community of South Shafter (Smith's Corner, Thomas Lane, Cherokee Strip, Burbank, Mexican Colony, Southwest Shafter)	Southern San Joaquin Municipal Utility District
County of Kern*	Tulare Basin Wildlife Partners*
Delano-Earlimart Irrigation District*	

\*Participant in both Kern and Poso Creek IRWM Groups

Of the key stakeholders listed in **Table 4-1**, the following agencies attended the public stakeholder meetings and/or submitted projects to be included in the Plan:

- Arvin-Edison Water Storage District
- Buena Vista Water Storage District
- County of Kern
- Delano-Earlimart Irrigation District
- Kern IRWM Group
- Lamont Storm Water District
- North Kern Water Storage District
- Poso Creek RWMG (Facilitator: GEI Consultants; Chairman: Dana Munn)



- Regional Water Quality Control Board
- Rosedale Rio Bravo Water Storage District
- Semitropic Water Storage District
- Shafter-Wasco Irrigation District

## 4.4 Nonprofit Organizations

Nonprofit organizations that are resources for water resource planning and/or management in the watershed include Self-Help Enterprises ([www.selfhelpenterprises.org](http://www.selfhelpenterprises.org)) and Community Water Center ([www.communitywatercenter.org](http://www.communitywatercenter.org)). As discussed in Section 15.3 of the Kern IWRMP, both groups work with DACs in the San Joaquin Valley, and are actively involved in water issues.

- **Self-Help Enterprises** – Self-Help Enterprises is a nationally recognized community organization with a mission to work with low-income families to build and sustain healthy homes and communities. Self-Help is currently working with DACs throughout the San Joaquin Valley, including Kern County, to develop water projects. The organization works with these communities to seek funding and provide technical assistance to communities with contaminated water sources who are working towards community-wide solutions that will result in a permanent source of clean drinking water. Because of their work with DACs, Self-Help can be an asset to engage during the public participation phase of projects.
- **Community Water Center** – The Community Water Center advocates for policies and practices at the state and regional level to prevent contamination of drinking water supplies of communities throughout the San Joaquin Valley. Because of their dedicated work for remediation for drinking water contamination and overall groundwater protection, their advocates may want to be involved in the implementation phase of the Plan, as projects (specifically the projects that will impact DACs) move into the planning and public participation phases.

Additional nonprofit organizations may be identified as more detailed stakeholder lists are put together for each specific project listed in this Plan.

## 4.5 Public Engagement/Communication Plan and Coordination

### 4.5.1 Overview of Public Engagement/Communication Plan

Guidelines and implementation processes for education, outreach and public participation opportunities associated with the Kern Storm Water Resource Plan have been established. Through the initial phases of Plan development, key stakeholders were included when considering major technical and policy issues related to the development and implementation of the Plan, such as what the ultimate purpose was in the development of the SWRP and plan components, who was going to be involved in the development, how projects would be solicited from stakeholders, gathered and included in the Plan, and development of the process for updates and the addition of projects in the future. The goal was to encourage public participation in projects benefitting stakeholders and promote the resource goals of the Plan.

Following the adoption of the Plan, the goal of future education, outreach and public participation efforts will be to engage the public, specifically community members who will be affected by project design and implementation, and engage disadvantaged and climate vulnerable communities within the plan boundaries. Project proponents will be encouraged to engage the public during the planning, design and construction phases of their projects.

Communication efforts for development and implementation phases of the Plan will be conducted through a variety of outreach methods including: educational public meetings and workshops; development and distribution of educational materials; utilization of media outlets and agency websites; and direct community outreach.

## 4.5.2 Public Meetings during Plan Development

### 4.5.2.1 Public Meeting No. 1 – May 31, 2016

Agencies, non-governmental organizations (NGOs), and other stakeholders included in the Kern and Poso Creek IRWMPs were invited to participate in an initial public meeting, held on May 31, 2016 at the Shafter-Wasco Irrigation District. Representatives of these agencies and other entities were invited to attend via an email “blast”, which included a link to a RSVP form set up to via Google Forms to gather information from those who would be attending. The email blast was sent to the email lists developed over the years by both IRWM Groups, which include federal and state agencies, local water agencies, cities and communities (including DACs), special districts, NGOs, political leaders, agricultural community representatives, community activists, etc.

Priority items covered on the agenda for the first public meeting consisted of:

- **Background** – Discussion included explaining that recognition of storm water as a resource, emphasizing multiple-benefit projects, the requirement of public agencies to develop a SWRP prior to receiving grant funding for storm water-related projects.
- **Purpose and Need for a Storm Water Resource Plan** – The traditional approach to storm water management vs. a watershed-based approach was explained. The traditional approach focuses on implementation of management practices, and is limited to treatment prior to conveyance off-site and ultimately into surface waters, and does not fully address the water quality impacts from storm water discharges. There is also limited consideration of multiple benefits such as water supply augmentation and ecological enhancement with a traditional approach.

A watershed-based approach replicates natural hydrology and watershed processes by managing storm water and dry weather run-off onsite or within the watershed where rainfall occurs, and yields multiple water quality benefits by reducing the volume of run-off delivered to receiving waters, thus reducing the pollutants discharged. In addition, it yields non-measurable social and community benefits that the traditional approach does not provide. Watershed-based approach projects are eligible to receive state grant funding through Proposition 1.

- **Storm Water Resource Plan Requirements** – A SWRP must be developed on a watershed-basis; prioritize use of public lands; provide multiple benefits for project design; quantitatively prioritize projects; provide for community participation; and not jeopardize

water quality. In addition, the Plan may build off of existing documents but does not need to be consistent with local IRWMPs, and must be submitted to the local IRWMPs for incorporation.

- **Kern Storm Water Resource Plan Components** – The presentation reviewed the components of a SWRP, which will include a description and scale of a watershed to be covered by the Plan; coordination and collaboration during plan development; benefit metrics to be used to identify and prioritize projects; general guidance on metrics-based analysis of project performance proposed to fulfill watershed needs; data collection and management; prioritization of projects to proceed to implementation; and adaptive management, plan implementation and public participation during implementation.
- **Project Submittal Form Review** – Forms were provided via hard copy and by email to agencies in the Kern and Poso Creek IRWMPs and were due by June 24. The agencies submitted the 12 Project Submittal Forms, which are included in **Appendix B: Project Submittal Forms**. The forms are necessary to gain information for projects submitted to be included in the Plan and consisted of the following sections:
  - Part 1. Lead Implementing Agency/Organizational Information
  - Part 2. Project Need (necessary to understand the need/issue that the proposed project will address and the benefits it will provide.
  - Part 3. Project Description
  - Part 4. Project Benefits (Water Quality, Water Supply, Flood Management, Environmental and Habitat Enhancement, Community Stewardship)
- **Public Meeting Scope and Tentative Date** – The next public meeting will be held in the Fall to review the draft Kern SWRP, receive comments from stakeholders and the public, and answer any questions.
- **Questions & General Discussion** – Comments and discussion focused on eligibility for state funding; definition of a DAC; Plan boundaries including location and methodology for defining the boundaries; cost of developing the Plan; process for soliciting feedback on the Plan; and further clarification on completing the Project Submittal Form.

Following the meeting, a summary of the meeting discussion notes, a PDF copy of the Power Point presentation, and the Project Submittal Form was sent via email to all of the key stakeholders of the Kern and Poso Creek IRWMPs.

#### 4.5.2.2 Public Meeting No. 2 – November 9, 2016

A second public meeting was held on November 9, 2016 at the Buena Vista Water Storage District in Buttonwillow, California. Representatives of agencies within the Kern and Poso Creek IRWMPs were invited to participate using the same meeting notification process described in Section 4.5.2.1 for the first public meeting held in May. The main purpose of the second public meeting was to review and discuss the draft Kern SWRP, which was distributed for a three-week public review by email on October 21, 2016 and posted on [www.kernirwmp.com](http://www.kernirwmp.com).

The meeting consisted of an overview of each SWRP section and corresponding discussion amongst stakeholders regarding additions and/or revisions to the draft Kern SWRP before finalizing and publishing.

Following the specific discussion regarding the draft SWRP, the “next steps” were discussed, including addressing comments received during the public review period and publishing the report, the report adoption process (further discussed in **Section 6**), a self-certification checklist process (included in **Section 8** of this Plan), and developing a process for future updates to the Kern SWRP and addition of projects (discussed in **Section 5.6**).

## 4.6 Local, State, Federal Decisions, Code Changes or Legislations Needed for Plan Implementation

Generally, projects that have significant impacts on storm water resources within regions require decisions to be made by local, state or federal regulatory agencies in order for SWRP and project implementation to be successful. Coordination between local agencies will be essential for watershed-based regional monitoring and will be addressed through the collaboration of the Kern and Poso Creek IRWMP agencies, as needed. In addition, some interaction with local, state and federal agencies may be required for permitting and environmental processes.

### 4.6.1 Local, State and Federal Decisions, Code Changes or Legislations

Board actions, code changes or legislation needed for specific potential projects discussed in this Plan are detailed in **Table 4-2**. As a summary, the projects may be implemented through specific agency/district board approval; however grant funding will need to be acquired for some of the projects. No specific code changes or legislation will be required on local, state or federal levels for Plan or project implementation.

Table 4-2. Board Actions, Code Changes, or Legislation Required for SWRP Projects

Board Actions, Code Changes, or Legislation Required for SWRP Projects		
Potential Project	Implementing Agency/Organization	Board Actions, Code Changes, or Legislation
101. Schuster Spreading Grounds	Semitropic Water Storage District	May be implemented by Board approval
102. Pond-Poso Spreading Grounds, Phase 2	Semitropic Water Storage District	May be implemented by Board approval
103. Stored Water Recovery Unit, Element of the Semitropic Groundwater Bank	Semitropic Water Storage District	Board authorization needed to fund project
104. Entrance Ponds to the Pond Poso Spreading Grounds	Semitropic Water Storage District	May be implemented by Board approval
105. Caliente Creek Habitat Restoration and Groundwater Recharge Projects (Design & Construction)	County of Kern – Public Works Department	State approval needed for grant funding; local approval needed for project to proceed, as well as local financial participation
106. Cuddy Creek Restoration Project	County of Kern – Public Works Department	State approval need for grant funding; local approval needed for project to proceed, as well as local financial participation
107. Sandy Creek Bank and Erosion Protection Project	County of Kern – Public Works Department	None
108. The Palms Storm Water Recharge and Recovery Project	Buena Vista Water Storage District	None
109. Stockdale East Groundwater Recharge Project	Rosedale-Rio Bravo Water Storage District	May be implemented by Board approval
110. Western Rosedale In-Lieu Service Area Project	Rosedale-Rio Bravo Water Storage District	May be implemented by Board approval
111. James Groundwater Storage and Recovery Project	Rosedale-Rio Bravo Water Storage District	May be implemented by Board approval from District and partnering agency, Buena Vista Water Storage District's Board
112. Shafter-Wasco Irrigation District Recharge Project	Shafter-Wasco Irrigation District	May be implemented by Board approval

## 4.6.2 Federal, State or Local Agency Interaction for Permitting and Environmental Processes

As projects within the Plan are implemented, there will be interaction required with federal, state and local agencies for permitting and environmental documentation processes and approvals. Permits and environmental documents may need to be obtained, depending on the project location, or amended (if these documents or permits already exist). Permits and documentation may consist of:

- **Permits** – Storm Water Pollution Prevention Plans (SWPPP); encroachments; local grading permits; Streambed Alteration Agreements; Section 401 and 404 Permits
- **Environmental Documents** – CEQA and/or National Environmental Protection Act (NEPA) documentation; Indirect Source Reviews (ISR); Dust Control Plans (DCP)

### 4.6.2.1 State and Federal Agencies

As described in [Section 4.6.2](#), coordination with state and federal agencies will be necessary for implementation of the Plan and listed projects. These agencies will be contacted in order to fulfill

permitting and environmental documentation requirements, and will be included in project communications including public participation strategies, if necessary. These agencies include:

- **State Water Resources Control Board/Regional Water Quality Control Board** – The SWRCB and the CVRWQCB (District 5 is responsible for the Kern Watershed boundaries) are responsible for working in coordination with each other to preserve, protect, enhance and restore water quality within the state. The SWRCB administers the Proposition 1 Storm Water Grant Program (SWGPP), which funds multi-benefit storm water management projects that improve regional water-reliance, security, and adapt to the effects on water supply through climate change. The connected agencies oversee permitting processes for storm water such as the SWPPP, and 401 permits (a permit that protects water quality), and will be involved in projects that are implemented from this Plan.
- **California Department of Water Resources (DWR)** – The DWR is the state agency responsible for overseeing the IRWM programs statewide, which includes administering the Proposition 1 IRWM Grant Program, which provides funding for projects that help meet the long term water resource needs within IRWM Regions. Kern and Poso Creek IRWM agencies/districts may need to work with the DWR to obtain grant monies to fund projects listed in the Kern SWRP. Criteria for obtaining Proposition 1 grant funds include: assisting water infrastructure systems to mitigate impacts from climate change; providing incentives throughout each watershed to collaborate in managing a region’s water resources and setting regional priorities for water infrastructure; and improving regional water self-reliance, while reducing reliance on Sacramento-San Joaquin Delta. In addition, the DWR is responsible for overseeing the enhancement of water resources within DACs.
- **California Department of Fish & Wildlife (CDFW)** – The CDFW is responsible for permitting programs that fulfill their mission to manage California’s diverse fish, wildlife, and plant resources, and their habitats. These permitting and environmental documentation programs include the California Endangered Species Act (CESA) program, CEQA program, and the Lake and Streambed Alteration Program. Any projects that affect endangered species or the overall environment, coordination with the CDFW will be required.
- **Federal Emergency Management Agency (FEMA)** – FEMA is a federal agency that works throughout the country to build, sustain and improve hazards that affect communities. Specifically for projects within the SWRP boundaries, FEMA may need to be involved with projects that will consist of flood management.
- **U.S. Army Corps of Engineers (USACE)** – USACE’s principle focus is environmental sustainability, with the goal to deliver essential water resource solutions throughout the nation. Their programs focus on flood risk management, ecosystem restoration and infrastructure, recreation and natural resource management, hydropower, wetlands and waterways regulatory, and water supply. Any SWRP projects that may result in discharge of dredge and fill material to a body of water will likely need to coordinate with the USACE to obtain the necessary permits under Section 404 of the Clean Water act.
- **U.S. Fish & Wildlife Service (USFWS)** – The USFWS is responsible for permits that provide a means to balance use and conservation of protected species, and use permits as a conservation tool to promote long-term protection of animals, plants, and their habitats. For SWRP projects that will affect the habitats of native endangered and threatened species

(as identified under the Endangered Species Act) or Migratory Bird, then coordination with the USFWS will be required.

## 4.7 Planning and Coordination among Existing Local Government Agencies for Plan Implementation

Planning and coordination with existing local governmental agencies has been part of the development phase of the Plan, and will continue through the implementation phase. For the success of these projects, some may require collaboration between local agencies as projects affect potential banking partners, neighboring water districts, cities, and DACs (cities and communities within Kern County are shown in **Figure 8**). In addition, local government agencies that will most likely be involved in project implementation include:

- **County of Kern** –As the projects included in this Plan begin to move into the implementation phase, County coordination may be required for encroachment, local grading, and other local permits, depending on the specific project’s location and district boundaries. It should be noted that the County of Kern was represented at the initial public meeting held in May 2016, and the agency submitted three projects for inclusion in the SWRP.
- **San Joaquin Valley Air Pollution Control District (Air District)** – The Air District oversees the improvements to the health and quality of life for San Joaquin Valley residents through air quality improvement programs. For any projects that require air quality permits including those affecting Greenhouse Gas Emissions, as well as ISRs and DCPs, as identified in project-specific environmental documents, cooperation with the Air District will be necessary.

## 4.8 Relationship of Plan with Other Existing Planning Documents

### 4.8.1 Projects within the Kern Region & Relationship with Existing IRWMP Documents

Agencies within the Kern Region completed Project Submittal Forms detailing future projects that meet the requirements to the Storm Water Resource Plan Guidelines established by the SWRCB on December 15, 2015. All of the projects submitted for inclusion in the Plan were also listed in either the Kern IRWMP or the Poso Creek IRWMP, and are listed in **Table 4-3**. Because these projects are listed in the Plan and one of the other adopted IRWMPs, public outreach/participation efforts will be coordinated for consistency and efficiency for compliance with both IRWMP and SWRP requirements.

Table 4-3. Storm Water Resource Projects

Storm Water Resource Projects			
Implementing Agency/Organization	Possible Partnering Agencies	Project	Other Plans Project is Included In
Semitropic Water Storage District	N/A	Schuster Spreading Grounds	Poso Creek IRWMP
Semitropic Water Storage District	N/A	Pond-Poso Spreading Grounds, Phase 2	Poso Creek IRWMP
Semitropic Water Storage District	N/A	Stored Water Recovery Unit, Element of the Semitropic Groundwater Bank	Poso Creek IRWMP
Semitropic Water Storage District	N/A	Entrance Ponds to the Pond Poso Spreading Grounds	Poso Creek IRWMP
County of Kern – Public Works Department	Arvin-Edison Water Storage District, Lamont Stormwater Utility District	Caliente Creek Habitat Restoration and Groundwater Recharge Projects (Design & Construction)	Kern IRWMP
County of Kern – Public Works Department	N/A	Cuddy Creek Restoration Project	Kern IRWMP
County of Kern – Public Works Department	City of Taft	Sand Creek Bank and Erosion Protection Project	Kern IRWMP
Buena Vista Water Storage District	West Kern Water Storage District, Rosedale-Rio Bravo Water Storage District, potentially other Kern IRWMP districts	The Palms Storm Water Recharge and Recovery Project	Kern IRWMP
Rosedale-Rio Bravo Water Storage District	N/A	Stockdale East Groundwater Recharge Project	Kern IRWMP
Rosedale-Rio Bravo Water Storage District	N/A	Western Rosedale In-Lieu Service Area Project	Kern IRWMP
Rosedale-Rio Bravo Water Storage District	Buena Vista Water Storage District	James Groundwater Storage and Recovery Project	Kern IRWMP
Shafter-Wasco Irrigation District	Buena Vista Water Storage District	Shafter-Wasco Irrigation District Recharge Project	Poso Creek IRWMP

#### 4.8.2 DAC Studies within Kern Region

There are several disadvantaged communities within the Kern Region (**Table 4-4** and **Figure 9**). Of the 12 projects submitted, three are located within and/or adjacent to a DAC, and will require public participation efforts in those communities once the Plan has been adopted and the projects begin to come to fruition. The process for the public participation efforts is detailed in **Section 7**. The impact of the submitted projects on the DACs within the Plan boundaries is outlined in **Table 4-4**.



Table 4-4. Disadvantaged Communities within the SWRP Boundary

Disadvantaged Communities within the SWRP Boundary		
Community	Population	Households
City of Arvin	20,028	4,595
City of Tehachapi	13,818	3,269
City of Delano	52,883	10,549
City of McFarland	12,784	2,817
City of Maricopa	1,158	395
City of Shafter (including Bishop Acres, Madonna, Maple Elementary School, Thomas Lane, Burbank)	17,261	4,434
City of Wasco	25,865	5,264
Blackwell's Corner		
Bodfish	1,961	1,043
Buttonwillow	1,371	378
Cherokee Strip (South Shafter)	295	68
Derby Acres	324	145
Dustin Acres	295	128
Earlimart	8,310	1,903
Edmundson Acres	274	54
Ford City	4,154	1,323
Frazier Park	2,730	958
Fuller Acres	924	262
Lake Isabella	3,093	1,417
Lake of the Woods	539	292
Lamont	16,359	3,606
Lost Hills	2,194	452
McKittrick	112	38
Mettler	88	31
Mexican Colony (South Shafter)	216	63
Mountain Mesa	454	156
Oildale	33,879	12,308
Onyx	599	217
Pine Mountain Club	1,890	825
Richgrove	3,006	628
Rodriguez Farm Labor Camp	192	39
Smith's Corner (South Shafter)	661	137
South Taft	1,680	471
Squirrel Mountain Valley	372	180
Tupman	176	45
Valley Acres	717	227
Weedpatch	2,170	583
Weldon	2,604	1,236
Wofford Heights	2,043	992

Table 4-5. DAC Involvement

DAC Involvement				
Implementing Agency/Organization	Potential Project	Project Located within or adjacent to a DAC?	Requires DAC Participation?	DACs Involved
Semitropic Water Storage District	Schuster Spreading Grounds	No	No	N/A
Semitropic Water Storage District	Pond-Poso Spreading Grounds, Phase 2	No	No	N/A
Semitropic Water Storage District	Stored Water Recovery Unit, Element of the Semitropic Groundwater Bank	No	No	N/A
Semitropic Water Storage District	Entrance Ponds to the Pond Poso Spreading Grounds	No	No	N/A
County of Kern – Public Works Department	Callente Creek Habitat Restoration and Groundwater Recharge Projects (Design & Construction)	Adjacent	Yes	City of Arvin and Community of Lamont; Lamont Storm Water District
County of Kern – Public Works Department	Cuddy Creek Restoration Project	Within, Adjacent	Yes	Frazier Park
County of Kern – Public Works Department	Sand Creek Bank and Erosion Protection Project	Within, Adjacent	Yes	City of Taft, Ford City
Buena Vista Water Storage District	The Palms Storm Water Recharge and Recovery Project	Adjacent		City of Taft, City of Buttonwillow, Community of Tupman
Rosedale-Rio Bravo Water Storage District	Stockdale East Groundwater Recharge Project	No	No	N/A
Rosedale-Rio Bravo Water Storage District	Western Rosedale In-Lieu Service Area Project	No	No	N/A
Rosedale-Rio Bravo Water Storage District	James Groundwater Storage and Recovery Project	No	No	N/A
Shafter-Wasco Irrigation District	Shafter-Wasco Irrigation District Recharge Project	No	No	N/A

### 4.8.3 Other Existing Planning Documents, Ordinances and Programs

In addition to the Kern IRWMP and Poso Creek IRWMP, a number of plans, studies and grant applications related to storm water and water resource management within the Kern Region have had an impact on the development of this Plan and the storm-water related projects that are part of it. In order to stay consistent with regional goals for the Kern County area, it is important to have these documents as a resource. Other existing planning documents, ordinances and programs that were noted by the implementing agencies/organizations to be associated with projects listed in the SWRP are listed in **Table 4-6**. Other plan/document resources that are not noted in the table include the Kern County General Plan, City of Bakersfield General Plan, City of Delano General Plan, City of Shafter General Plan, City of Taft General Plan, City of Tehachapi General Plan, Greater Tehachapi Area Specific Plan, City of Wasco General Plan, and Kern River Valley Specific Plan.

Section Four: Organization, Coordination and Collaboration  
Kern Storm Water Resource Plan

Table 4-6. Other Existing Planning Documents Associated with Kern SWRP Projects

Other Existing Planning Documents Associated with Kern SWRP Projects		
Implementing Agency/Organization	Potential Project	Other Existing Documents
Semitropic Water Storage District	Schuster Spreading Grounds	None
Semitropic Water Storage District	Pond-Poso Spreading Grounds, Phase 2	<ul style="list-style-type: none"> <li>• District CEQA Document (IS/ND), 2007</li> <li>• Federal-Funded ARRA grant for Phase I completion</li> </ul>
Semitropic Water Storage District	Stored Water Recovery Unit, Element of the Semitropic Groundwater Bank	<ul style="list-style-type: none"> <li>• Supplemental and Final Environmental Impact Report</li> </ul>
Semitropic Water Storage District	Entrance Ponds to the Pond Poso Spreading Grounds	<ul style="list-style-type: none"> <li>• 2010 WaterSMART Pond – Poso Retention Ponds Phase II Grant Application</li> <li>• District CEQA Document (IS/ND), 2007</li> </ul>
County of Kern – Public Works Department	Caliente Creek Habitat Restoration and Groundwater Recharge Projects (Design & Construction)	<ul style="list-style-type: none"> <li>• Caliente Resource Management Plan, 1998</li> </ul>
County of Kern – Public Works Department	Cuddy Creek Restoration Project	<ul style="list-style-type: none"> <li>• 2008 Urban Stream Restoration Program, Grant Application (11/12/2008)</li> <li>• Preliminary Design and Feasibility Report by Questa Engineering (November 2003)</li> <li>• Final Design Report by Questa Engineering (April 2004)</li> </ul>
County of Kern – Public Works Department	Sand Creek Bank and Erosion Protection Project	<ul style="list-style-type: none"> <li>• Sandy Creek Flood Control Project, J.H. Hansen Engineering (March 1986 for the Kern County Water Agency)</li> <li>• Sandy Creek Hydrology Study by Meyer Civil Engineering for the City of Taft (September 2, 2005)</li> </ul>
Buena Vista Water Storage District	The Palms Storm Water Recharge and Recovery Project	<ul style="list-style-type: none"> <li>• Initial Study/Mitigated Negative Declaration for Palms Groundwater Banking Project</li> <li>• Geology and Hydrology Review of The Palms Groundwater Recharge and Recovery Project, Robert A. Crewdson, PhD</li> </ul>
Rosedale-Rio Bravo Water Storage District	Stockdale East Groundwater Recharge Project	<ul style="list-style-type: none"> <li>• 2016 WaterSMART Water and Energy Efficiency Grant Application</li> </ul>
Rosedale-Rio Bravo Water Storage District	Western Rosedale In-Lieu Service Area Project	<ul style="list-style-type: none"> <li>• 2016 Agricultural Water Conservation and Efficiency Grants</li> </ul>
Rosedale-Rio Bravo Water Storage District	James Groundwater Storage and Recovery Project	<ul style="list-style-type: none"> <li>• 2015 Draft Environmental Impact Report</li> </ul>
Shafter-Wasco Irrigation District	Shafter-Wasco Irrigation District Recharge Project	<ul style="list-style-type: none"> <li>• Shafter-Wasco Irrigation District Recharge Project Final Initial Study and Mitigated Negative Declaration, February 2015</li> </ul>

# 5 Identification and Prioritization of Projects

## 5.1 Introduction

One of the main purposes of the Storm Water Resource Plan is to begin the process of developing storm water and dry weather runoff capture projects and to make these projects eligible to receive grant funding from state agencies. SB 985, which amended Water Code section 10560, subdivision (c)(1), requires that for the purpose of obtaining grant funds from any state bond act, such projects must be included in a SWRP. This requirement was passed into law and became effective in January 2014.

The SWRP Guidelines require a list of prioritized projects, ratified by the IRWMP groups, to be included with the Plan. The projects must be ranked based on their ability to deliver Main and Additional Benefits to the Plan area. The guidelines do not delineate a methodology to be used for ranking the projects, but state that a system of quantitative, score-able metrics must be used to evaluate the proposed projects. The intent is to characterize and rank projects, develop a list of prioritized projects based on the ranking, and include the list within the Plan. The Plan will be reviewed and approved by stakeholders within the Kern IRWMP and Poso Creek IRWMP. Stakeholders in both IRWMP groups contributed a total of 12 project proposals. **Section 5** explains the methodology used to characterize, rank, and prioritize the projects and presents the prioritized list based on the scoring metrics.

## 5.2 Project Submittal Form – Purpose and Use

**Appendix B: Project Submittal Forms** is comprised of the Project Submittal Forms (PSFs) submitted by stakeholders for inclusion in the Plan. The PSF is not a grant application, but serves as a means of communicating conceptual projects which fit in with the Plan's resource goals. The PSF template was developed following guidance stated in the guidelines, conforming to the SWRP Guidelines' checklist on pages A-1 through A-10. The PSFs were set up to be readily score-able to allow comparing, scoring, ranking, and prioritizing projects included with the Plan. The guidelines state that projects submitted for inclusion in the Plan must demonstrate a minimum of two or more Main Benefits and as many Additional Benefits as possible. Main and Additional Benefits are described in **Section 5.4** and are presented in Table 3 on pages 22-23 of the SWRP Guidelines.

The PSF template was reviewed and commented on by IRWMP group participants during the first public meeting and subsequently revised to reflect their input. Representatives from both Poso Creek and Kern IRWMP groups agreed to the revised PSF and subsequently submitted 12 projects for inclusion in the Plan, which are included in **Appendix B: Project Submittal Forms**.

## 5.3 Project List Unranked – Side-by-Side Comparison of Submitted Projects

**Table 5-1** presents a summary of the proposed projects submitted in the PSFs to enable side-by-side comparison of how proposed projects deliver Main and Additional Benefits. It allows the reader to visualize the geographic area covered by all submitted projects, identify areas of overlap, and compare how resource goals are addressed by the two IRWMP groups.

Table 5-1. Summary of Proposed Projects

Summary of Proposed Projects											
Project No. & Sponsor Designator	Type of Project	Project Sponsor	Project Name	Location Description	IRWMP	Latitude/ Longitude	Water Supply Benefits <i>Metric: Annual yield of supply created (acre-feet)</i>	Water Quality Benefits <i>Metric: Pollutant load reduced or Volume treated</i>	Flood Management Benefits <i>Metric: Volume or flows impounded or diverted (acre-feet or cfs)</i>	Environmental and Habitat Enhancement Benefits <i>Metric: Acres enhanced, flows improved (cfs)</i>	Community Stewardship Benefits <i>Metric: Acres made available, number of jobs created, number of people served</i>
101_SWSD	Conjunctive use/recharged groundwater	Semitropic Water Storage District	Schuster Spreading Grounds	Northwest of the intersection of Shuster Road and Highway 43, about 5.8 miles southwest of Delano, within the west half of Section 24, Township 25 South, Range 24 East, MDB&M.	Poso Creek	35.740073 / -119.340199	Average Year: 577AFY = 332AFY + 245AFY based on removal of crop demand plus delivery of surface supplies to the Schuster SGs similar to the PPSGs at a frequency of 2 wet years out of 10 years Dry year: 245 af/yr      Wet year: 1903 af/yr	Enhancement of groundwater quality due to decreased pumping lifts and stabilization of the water table, which reduces the chances of water quality changing due to pumping from zones of less quality; and enhancements to water quality due to the importation of surface water to the District in wet years, which delivers surface water of quality suitable for the beneficial uses within the region.	Up to 224 Ac-ft diverted into detention basin, reducing flood risk to local drainage area of Poso Creek. In the case of Semitropic's Water Bank and direct recharge facility, flood flow is delivered via the CA Aqueduct into the District's conveyance system, or, it is delivered via Poso Creek as diverted CVP-Friant or locally, Poso Creek Stormwater, therefore, the added absorptive capacity of direct recharge enhances the ability to receive flows during wet periods, typically corresponding to times of the year when irrigation demand is low. This Project enhances flood management of the CA Aqueduct in reducing flood risk by allowing diversions into the CA Aqueduct, upstream of the Semitropic turnout.	The Project will provide waterfowl with a place to rest and nest, intermittently, when they have water in the ponds and are being utilized for recharge purposes.	The Project will provide jobs during construction. Once constructed, the facility provides a habitat for various birds and waterfowl that also provides an opportunity for the public to view the birds.
102_SWSD	Conjunctive use/recharged groundwater	Semitropic Water Storage District	Pond-Poso Spreading Grounds, Phase 2	The Project is 7 miles northwest of Wasco, adjacent to, and west and north of the existing Pond-Poso Spreading Grounds, Phase 1; south half of Section 8 and west half of Section 17, Township 26 South, Range 24 East, MDB&M.	Poso Creek	35.674436 / -119.411299	While a precise estimate of the annual amount of Stormwater or surface supply that will be delivered for direct recharge is challenging due to uncertainties and variation in annual supply, evaluation of the project's absorptive capacity can be estimated based on the acreage of Phase 2 compared to Phase 1 and the operation of Phase 1 during a recent wet period. A reasonable estimate of the absorptive capacity for the Phase 2 recharge facility is 15,163 acre-feet per wet year since it is the development of 4 quarter sections compared to the existing developed five quarter section area of Phase 1. Phase 1 was able to absorb 18,954 acre-feet of surface supply in 2011, a wet period. [15,163 = (4/5) * 18,954]  Additionally, the Project will convert 640 gross acres to ponds, resulting in an annual benefit of 2,240 AF [3.5 AFY per acre], for a total annual benefit of 5,273 AFY [5,273 AFY = 2,240 AFY + 3,033 AFY]. The Project would also: <ul style="list-style-type: none"><li>• Improve the reliability of water supply for Semitropic.</li><li>• Increase operational flexibility for delivery of State Water Project (SWP) water</li><li>• Increase direct spreading, absorptive capability within Semitropic</li><li>• Increase local unconfined groundwater quality.</li><li>• Make use of available groundwater storage.</li><li>• Contribute to the groundwater basin for use during periods of peak demand or when SWP water is not available.</li></ul>	The Project also has the potential to improve water quality as follows: <ul style="list-style-type: none"><li>• Enhancement of groundwater quality due to decreased pumping lifts and stabilization of the water table, which reduces the chances of water quality changing due to pumping from zones of less quality; and</li><li>• Enhancements to water quality due to the importation of surface water to the District in wet years, which delivers surface water of quality suitable for the beneficial uses within the region. The project Converts 640 acres of farmed land into recharge facility</li></ul>	The Project provides a flood management benefit inasmuch as the water delivered to the direct recharge facility during times of Stormwater management will be diverted and not contribute to increased downstream flows and flood risks. In the case of Semitropic's Water Bank and direct recharge facility, flood flow is delivered via the CA Aqueduct into the District's conveyance system, or, it is delivered via Poso Creek as diverted CVP-Friant or Poso Creek Stormwater, therefore, the added absorptive capacity of direct recharge enhances the ability to receive flows during wet periods, typically corresponding to times of the year when irrigation demand is low. This Project enhances flood management of the CA Aqueduct in reducing flood risk by allowing diversions into the CA Aqueduct, upstream of the Semitropic turnout.  Additionally, the Project also provides for a flood management benefit with the ability to divert wet-year water from Poso Creek into the recharge ponds. During flood events on Poso Creek, the recharge ponds could take occurring flood flows, thereby reducing flood damage within the Kern NWR and adjacent valuable agriculture lands.  Max increased conveyance capacity 350 cfs. Project has transitory storage capacity of up to 15,163 AF.	The Pond Poso Spreading Grounds has the potential to create seasonal or intermittent shallow open water habitat by providing benefits for upland habitat benches, which consist of enlarged earthen benches up to 80-foot wide to support waterfowl with a place to rest and nest, when they have water in the ponds and are being utilized for recharge purposes.	The Project has the potential for providing project benefits to the community as described below. Once constructed, the facility provides a habitat for various birds and waterfowl that also provides an opportunity for the public to view the waterfowl.

Summary of Proposed Projects											
Project No. & Sponsor Designator	Type of Project	Project Sponsor	Project Name	Location Description	IRWMP	Latitude/ Longitude	Water Supply Benefits <i>Metric: Annual yield of supply created (acre-feet)</i>	Water Quality Benefits <i>Metric: Pollutant load reduced or Volume treated</i>	Flood Management Benefits <i>Metric: Volume or flows impounded or diverted (acre-foot or cfs)</i>	Environmental and Habitat Enhancement Benefits <i>Metric: Acres enhanced, flows improved (cfs)</i>	Community Stewardship Benefits <i>Metric: Acres made available, number of jobs created, number of people served</i>
103_SWSD	Groundwater banking	Semitropic Water Storage District	Stored Water Recovery Unit, Element of the Semitropic Groundwater Bank	Within the northwest area of the SWSD, about 4 miles south of the north Kern County line	Poso Creek	35.679706 / - 119.508296	The put and take operation of the current Semitropic Groundwater Bank is limited by the availability of surface supplies, capacity of the existing intake, conveyance, and pump back facilities, and the ability to deliver (absorb) surface water using the lateral distribution and irrigation systems. With the proposed construction of a conveyance pipeline originating at the Pond-Poso Canal, an opportunity is created to significantly enhance the put, which is the absorptive capacity of the Groundwater Bank. This additional capacity, coupled with a balancing reservoir adjacent to the Pond-Poso Canal, could greatly enhance the operational flexibility of the put operation and increase the absorptive capacity of the in-lieu portion of the Bank. Ongoing water supply monitoring and data acquisition is done by the Semitropic Staff and communicated to the neighboring districts through the Semitropic Groundwater Monitoring Committee. The committee acquires and stores hydrology data collected by the District Staff, the Kern County Water Agency, and the DWR's CA Aqueduct operators. Creates up to 12,600 AF of additional annual yield for the SWRU in an average year and 42,000 AF in a wet year.	This project also has the potential to improve water quality as follows: <ul style="list-style-type: none"> <li>Enhancement of groundwater quality due to decreased pumping lifts and stabilization of the water table, which reduces the chances of water quality changing due to pumping from zones of less quality; and</li> <li>Enhancements to water quality due to the importation of surface water to the District in wet years, which delivers surface water of quality suitable for the beneficial uses within the region.</li> </ul>	The Project provides a flood management benefit inasmuch as the water stored will not contribute to increased downstream flows and flood risks from where the water is diverted. In the case of Semitropic's Water Bank, flood flow is delivered via the CA Aqueduct into the SWRU conveyance system, therefore, the added absorptive capacity enhances the CA Aqueduct in reducing flood risk by allowing diversions into the CA Aqueduct, upstream of the Semitropic turnout. <p>Additionally, the Project also provides for a flood management benefit with the construction of an overpour structure, control structure and regulating reservoir off of the Poso Creek Flood Channel. The facilities would allow the District to divert wet-year water from Poso Creek into the Regulation Reservoir, which would be subsequently pumped into the North-South Conveyance System. This creek-side facility would also allow the District to convey regulated water to the Kern NWR. During flood events on Poso Creek, the weir structure could take 300 cfs of the occurring flood flows, thereby reducing flood damage within the Kern NWR and adjacent valuable agriculture lands. Creates 8400 AF of transitory floodwater storage. and provides 300 cfs of increased conveyance capacity.</p>	A component of the Project, construction of the Regulation Reservoir, has the potential for developing and enhancing habitat and open space as described below. The reservoir will be located adjacent to and south of the Poso Creek Flood Channel within a larger parcel that will be used to regulate water diverted from Poso Creek from time to time and could ultimately be developed into a managed wetlands area. The current configuration of the reservoir is a "dumbbell" shape with the easterly levees curved and the exterior slopes flattened to enhance duck club aesthetics to accommodate an existing active duck club pond that is adjacent to and east of the reservoir. The configuration of the reservoir was coordinated with the adjacent duck club owner for this reason. Once constructed, the Regulation Reservoir, has the potential to provide a habitat for various birds and waterfowl that also provides an opportunity for the public to view the waterfowl. Provides up to 40 acres of wetland area.	A component of the Project, construction of the Regulation Reservoir has the potential for providing project benefits to the community as described below. As described above, once constructed, the Regulation Reservoir, has the potential to provide a habitat for various birds and waterfowl that also provides an opportunity for the public to view the waterfowl.
104_SWSD	Conjunctive use/recharged groundwater	Semitropic Water Storage District	Entrance Ponds to the Pond Poso Spreading Grounds	The Project is 7 miles northwest of Wasco, northeast and adjacent to the existing Pond-Poso Spreading Grounds, located in Section 9, Township 26 South, Range 24 East, MDB&M.	Poso Creek	35.682362 / - 119.392154	The Project, once fully developed, will provide the following estimated water supply benefits: <ul style="list-style-type: none"> <li>An estimated quantifiable water savings of 1,120 acre-feet per year based on the conversion of agricultural land to retention ponds (the estimated water savings per year is based on 320 gross acres of cropland with an applied water use of 3.5 acre-feet per year being converted to non-cropland);</li> <li>An additional 160 acre-feet per day capacity for aquifer recharge when the area is wet and in use as retention ponds (estimated rate of recharge is at minimum 0.5 acre-feet per day); and,</li> <li>Added flexibility for regional water management by adding a 350 cfs conveyance route from Poso Creek Flood Channel to the District's spreading facility and/or Pond Poso Canal for local surface water and CVP water supplies (equivalent volumes for the added route capacity of 350 cfs are 700 acre-feet per day or 21,000 acre-feet per month).</li> <li>Up to 1280 AF annual yield in an average year. Dry year: 1120 AF/yr; Wet year: 2720 AF/yr</li> </ul>	The Project will improve the quality of water by allowing for the removal of sediment prior to diverting the water to the District's Pond Poso Canal and/or the Pond Poso Spreading Grounds. In doing so it will also improve the effectiveness of the aquifer, recharge operation within the Pond Poso Spreading Grounds by decreasing the amount of silt that reaches the recharge ponds, maintaining recharge rates, and increasing total water supply benefit. It is recognized in the Poso Creek IRWMP area that the majority of recharge facilities are constructed and operated by the agricultural districts and not by the small disadvantaged communities or the environmental water users, this project also has the potential to improve water quality as follows: <ul style="list-style-type: none"> <li>Enhancement of groundwater quality due to decreased pumping lifts and stabilization of the water table, which reduces the chances of water quality changing due to pumping from zones of less quality; and</li> <li>Enhancements to water quality due to the importation of surface water to the District in wet years, which delivers surface water of quality suitable for the beneficial uses within the region.</li> </ul>	The Project provides a flood management benefit inasmuch as the water delivered to the direct recharge facility during times of stormwater /floodwater management will be diverted and not contribute to increased downstream flows and flood risks. In the case of Semitropic's Water Bank and direct recharge facility, flood flow is delivered via the CA Aqueduct into the District's conveyance system, or, it is delivered via Poso Creek as diverted CVP-Friant or Poso Creek Stormwater, therefore, the added absorptive capacity of direct recharge enhances the ability to receive flows during wet periods, typically corresponding to times of the year when irrigation demand is low. <p>Additionally, the Project also provides for a flood management benefit with the ability to divert wet-year water originating from the Poso Creek Flood Channel into the PPSG recharge ponds and/or the Pond Poso Canal. During flood events on Poso Creek, the recharge ponds could take occurring flood flows, thereby reducing flood damage within the Kern NWR and adjacent valuable agricultural lands. Transitory storage: 1024 AF; Max increased conveyance: 350 cfs</p>	The Entrance Ponds to the Pond Poso Spreading Grounds has the potential to create seasonal or intermittent shallow open water habitat by providing benefits for upland habitat to support waterfowl with a place to rest and nest, when water is in the ponds and are being utilized for recharge purposes. 256 acres of non-treatment wetland area and 64 acres of open space.	The Project has the potential for providing project benefits to the community as described below. Once constructed, the facility provides a habitat for various birds and waterfowl that also provides an opportunity for the public to view the waterfowl. creates 64 acres of open space.

Summary of Proposed Projects											
Project No. & Sponsor Designator	Type of Project	Project Sponsor	Project Name	Location Description	IRWMP	Latitude/ Longitude	Water Supply Benefits <i>Metric: Annual yield of supply created (acre-feet)</i>	Water Quality Benefits <i>Metric: Pollutant load reduced or Volume treated</i>	Flood Management Benefits <i>Metric: Volume or flows impounded or diverted (acre-foot or cfs)</i>	Environmental and Habitat Enhancement Benefits <i>Metric: Acres enhanced, flows improved (cfs)</i>	Community Stewardship Benefits <i>Metric: Acres made available, number of jobs created, number of people served</i>
105_KC	Habitat mitigation and groundwater recharge	County of Kern—Public Works Department	Caliente Creek Habitat Restoration and Groundwater Recharge Projects—Design and Construction	Caliente Creek. Near State Route 58 and Arvin, Kern County	Kern	35.28266 / -118.6361	Un-quantified amount of groundwater capture. The capture of storm water and flood flows in proposed groundwater recharge basins will provide additional water to underlying aquifers.	Un-quantified decrease in sediment deposition to downstream areas	Approximately 1,500 acres is proposed to be converted back to natural riparian habitat upstream of the proposed groundwater recharge basins. This riparian habitat will provide natural treatment and infiltration to waters flowing in Caliente Creek. The proposed groundwater recharge basins will capture and meter flow and thus reduce the flooding issues presently downstream.	The Caliente Creek Habitat Mitigation project proposes the conversion of approximately 1,300 acres back to riparian habitat. Currently most of the area is under cultivation. It is proposed to re-introduce native plant species to help maintain a diverse population in the region.	Currently there will be no community/public projects to utilize storm water other than for ground water recharge.
106_KC	Habitat restoration and streambank stabilization.	County of Kern—Public Works Department	Cuddy Creek Restoration Project	This project is located at Cuddy Creek in Frazier Park, Kern County	Kern	34.82131 / -118.95026	Un-quantified amount of groundwater recharge opportunity. The groins will slow the water and provide areas of additional groundwater infiltration and recharge.	No established TMDL. The proposed project includes the construction/ placement of grade control structures, planted groins, and vegetation groins. The purpose of this project is to reduce watershed soil erosion and sedimentation of surface water to reduce the discharge of pollutants to State waters from storm or nonpoint sources.	Approx 2 acres adjacent to 3000 linear feet of the channel will be preserved from erosion. The channel erosion has stripped all of the top soil from much of the channel bed leaving barren rock. As these banks erode laterally, homes that were originally constructed a safe distance from the creek may now become placed in peril. This project will prevent further watershed soil erosion and reduce the discharge of pollutants to State waters from storm or nonpoint sources.	The Cuddy Creek Restoration Project will use planted groins and rock groins to re-establish natural controls to mitigate and reduce the dangerously uncontrolled erosion problems. Cuddy Creek will be less capable of lateral migration (less bank erosion) and should develop meadows where there is currently only bare rock and/or poorly graded sediments. Once established, the restored riparian corridor will provide an ideal habitat for trout (Cuddy Creek is annually stocked with trout) and native wildlife.	It is anticipated the community would be involved in planting some trees along the banks and on the rock groins and the meandering sidewalk along Cuddy Creek would lend itself to the locals appreciating the new riparian habitat and participate in maintenance and beautification of the community.
107_KC	Detention basin/groins/grade control structures/bank armoring	County of Kern—Public Works Department	Sandy Creek Bank and Erosion Protection Project	Ford City Area, Kern County.	Kern	35.15198 / -119.46063	Un-quantified amount of groundwater recharge opportunity. The groins will slow the water and provide areas of additional groundwater infiltration and recharge. There is no specific storm water capture proposed. Just natural infiltration along Sandy Creek and at the detention basin located at Midoil Road.	No established TMDL. The proposed detention basin at Midoil Road will provide some increase in infiltration to groundwater. The proposed channel work, removal of non-native plants and construction of grade control structures will help with downstream sedimentation issues.	Project uses 40 acres to temporarily detain up to 187 acre-feet of storm water storage, protecting 600 acres of land from seasonal flooding. Provides 100-yearLOP to Ford City and Taft. The construction of the detention basin, shaping and armoring the stream banks to prevent additional erosion, and constructing a series of drop structures to slow the flow, reduce energy, will reduce the negative effects of erosion, degradation and aggradation.	None	None
108_BVWSD	Conjunctive use/recharged groundwater	Buena Vista Water Storage District	The Palms Storm Water Recharge and Recovery Project	Latitude/longitude is located at the approximate center of the proposed project recharge basin.	Kern	35°19'50"N / 119°23'11"W	Adds 20,000 AF annual yield. The Project will increase water supply by storing captured storm water in the local groundwater aquifer. Groundwater recharge is particularly timely in Kern County where the extended drought has depleted aquifers that are relied upon by users throughout the region. In addition, both components support conjunctive use by capturing storm water during the limited periods when it is available for aquifer replenishment and that, once stored, can be relied upon during dry periods. Water is conserved by recharging captured storm water in areas where stored water is readily accessible. Project will have an 1160 acre detention basin.	A portion of the captured storm water recharged in the Project will be treated to Title 22 standards, if treatment is needed to enable recovered water to be conveyed in the California Aqueduct to urban agencies in Southern California. All storm water recharged by the Project will pass through sediment basins and be filtered as it percolates through the soil profile. Recharge of storm water will also reduce the concentration of salts, nitrate, and arsenic in the underlying groundwater. Furthermore, BVWSD's western boundary is formed by the Coastal Range that is derived from marine and lacustrine deposits that tend to have marginal to poor quality groundwater (high salinity). The Project will increase groundwater levels in the southern portion of BVWSD, reducing the head gradient separating the good quality groundwater located on the basin floor and the poorer groundwater to the west.	Low lying developed areas in the San Joaquin Valley periodically are inundated by flood waters. The Tulare Lake area in particular is the recipient of floodwaters from the Kings, Kaweah, Tulare, Kern Rivers, and a number of smaller streams. A portion of the water recharged in the Project otherwise would have contributed to flooding of low-lying improved lands in Kern County near the Kern River Flood Channel, Kings County (Tulare Lake Bed), and other areas further North (adjacent to the San Joaquin River and Delta). However, the amounts are difficult to quantify because of the complexity of various floodwater pathways, impact location, and degree of impacts to developed lands.	Using captured storm water to maintain groundwater levels in Kern County will lower pumping lifts and consequently reduce energy use and greenhouse gas emissions. The Project will also increase base flow in regional streams, benefiting local habitats in stream channels and wetlands.	



Summary of Proposed Projects											
Project No. & Sponsor Designator	Type of Project	Project Sponsor	Project Name	Location Description	IRWMP	Latitude/ Longitude	Water Supply Benefits <i>Metric: Annual yield of supply created (acre-feet)</i>	Water Quality Benefits <i>Metric: Pollutant load reduced or Volume treated</i>	Flood Management Benefits <i>Metric: Volume or flows impounded or diverted (acre-feet or cfs)</i>	Environmental and Habitat Enhancement Benefits <i>Metric: Acres enhanced, flows improved (cfs)</i>	Community Stewardship Benefits <i>Metric: Acres made available, number of jobs created, number of people served</i>
109_RRBWSD	Conjunctive use/recharged groundwater	Rosedale-Rio Bravo Water Storage District	Stockdale East Groundwater Recharge Project	West of Bakersfield, immediately east of the intersection of Enos Lane (Highway 43) and Stockdale Highway.	Kern	35.349537 / -119.24776	<p>The project will save a total of 9,500 AFY by conserving groundwater directly as a result of the recharge of wet year water by this project. Annual Yield of Supply: Dry yr 800 AF; Average yr 9500 AF; Wet yr 29,800 AF.</p> <p>Hydrology shows that the region experiences wet years sufficient to provide supplies to the project about every three in ten years. That would result in an average of additional 5,700 AFY (0.3 x 19,000 AF) stored groundwater. Approximately 50 cfs of the Central Intake Pumping Plant – Phase 2 would be dedicated to serving this site. Given this evaluation is for a wet year, a more detailed evaluation of Stormwater available during a wet year is needed to refine the average annual amount of water supply benefit.</p> <p>An additional 90 cfs would be included to offer capacity to deliver state and federal water to existing recharge areas located approximately 1.5 miles north of the site (Superior Basins). This would give added access to recharge supplies and potentially add up to 10,000 AF into the groundwater basin during each wet year. Using the same wet-year probability, this would result in an average of 3,000 AFY (0.3 x 10,000 AF) of additional stored groundwater. An additional 800 AFY of water is conserved due to the retiring of the required 229 acres of land (229 acres x 3.5 AF/acre). Therefore, a total of 9,500 AFY would be conserved as a direct result of the project and the estimate of the portion directly related to stormwater needs refinement.</p>	<p>Providing a connection for Stormwater that is delivered as surface water to recharge sites increases infiltration of surface water to storage in groundwater and enhances quality of the basin. The surface water available during wet periods is delivered to spreading facility for direct recharge. The use of direct spreading facility as the recharge mechanism avoids adding nutrients and transporting constituents used in growing crops.</p>	<p>The Project provides a flood management benefit inasmuch as the water diverted and stored will not contribute to increased downstream flows and flood risks from where the water is diverted. Provides up to 19,000 AF of transitory storage and Max increased conveyance capacity 140 cfs</p>	<p>Like all spreading basins, the Project will provide some intermittent habitat for waterfowl, birds, and other species when in use. Intermittent use of 200 acres on non-treatment wetland area.</p>	<p>The Project will reduce groundwater pumping lifts and resulting energy savings. The savings will be shared with municipal and private well owners alike. Other activity includes bird watching.</p>
110_RRBWSD	Storm water conveyance to recharge facility	Rosedale-Rio Bravo Water Storage District	Western Rosedale In-Lieu Service Area Project	Between East Side Canal and Interstate 5, south of Bowerbank, and within the District	Kern	35.370275 / -119.376214	<p>The Project is expected to absorb surface supplies up to the in-lieu system design amount of 5,630 AFY in 80 percent of the years, providing surface water for use by farmers in the Project Area in-lieu of groundwater that would otherwise be pumped, thus, conserving an average annual amount of 4,500 AF and 5630 AF in a wet year.</p>	<p>It is recognized in the IRWMP area that the majority of recharge and in-lieu recharge facilities are constructed, operated, and used by the agricultural districts and the City of Bakersfield and not by the small disadvantaged communities or the environmental water users, this project also has the potential to improve water quality as follows:</p> <ul style="list-style-type: none"> <li>• Enhancement of groundwater quality due to decreased pumping lifts and stabilization of the water table, which reduces the chances of water quality changing due to pumping from zones of less quality; and</li> <li>• Enhancements to water quality due to the importation of surface water to the District in wet years, which delivers surface water of quality suitable for the beneficial uses within the region.</li> </ul>	<p>The Project provides a flood management benefit inasmuch as the water stored will not contribute to increased downstream flows and flood risks from where the water is diverted. Provides up to 900 AF of transitory storage and conveys up to 72 cfs of storm water flow.</p>	<p>By providing in-lieu groundwater recharge, the Project will reduce groundwater pumping lifts and resulting energy savings. The savings will be shared with municipal and private well owners alike.</p>	

Summary of Proposed Projects											
Project No. & Sponsor Designator	Type of Project	Project Sponsor	Project Name	Location Description	IRWMP	Latitude/ Longitude	Water Supply Benefits <i>Metric: Annual yield of supply created (acre-feet)</i>	Water Quality Benefits <i>Metric: Pollutant load reduced or Volume treated</i>	Flood Management Benefits <i>Metric: Volume or flows impounded or diverted (acre-feet or cfs)</i>	Environmental and Habitat Enhancement Benefits <i>Metric: Acres enhanced, flows improved (cfs)</i>	Community Stewardship Benefits <i>Metric: Acres made available, number of jobs created, number of people served</i>
111_RRBWSD	Groundwater banking	Rosedale-Rio Bravo Water Storage District	James Groundwater Banking and Recovery Project	The Project property, known locally as McAllister Ranch, is located in the City of Bakersfield, Kern County, California within Sections 16, 21, 22, and 23, Township 30 South, Range 26 East, Mount Diablo Meridian (MDM)	Kern	35.309774 / -119.189067	<p>The Project is expected to absorb surface supplies up to approximately 57,600 AFY. Annual Yield of Supply: Average Year 11,520 AF; Wet Year 57,600 AF</p> <p>Additionally, the project would:</p> <ul style="list-style-type: none"> <li>• Improve the regional reliability of water supply.</li> <li>• Increase operational flexibility.</li> <li>• Increase direct spreading and basin absorptive capability.</li> <li>• Increase local unconfined groundwater quality.</li> <li>• Make use of available groundwater storage.</li> <li>• Contribute to the groundwater basin for use during periods of peak demand</li> </ul>	<p>Water quality benefits would not apply as a primary benefit for this project. However, recharge basins within the District allow for direct recharge of surface water originating from the SWP, the CVP, Kern River usually suitable for irrigation. The sources vary in quality, but are all typically suitable for irrigation and do not degrade the groundwater basin from its designated use. This project also has the potential to improve water quality as follows:</p> <ul style="list-style-type: none"> <li>• Enhancement of groundwater quality due to decreased pumping lifts and stabilization of the water table, which reduces the chances of water quality changing due to pumping from zones of less quality; and</li> <li>• Enhancements to water quality due to the importation of surface water to the District in wet years, which delivers surface water of quality suitable for the beneficial uses within the region. Additionally, the District, Project, and City of Bakersfield are within the Kern Fan. The water quality benefits produced by the Project are shared with the City and other nearby municipal entities.</li> </ul>	<p>The Project provides a flood management benefit inasmuch as the water delivered to the direct recharge facility during times of Stormwater management will be diverted and not contribute to increased downstream flows and flood risks. Provides up to 57,600 AF of transitory storage at a flood water/ storm water diversion rate of up to 258 cfs</p>	<p>The Project will provide waterfowl with a place to rest and nest, intermittently, when they have water in the ponds and are being utilized for recharge purposes. Provides 526 acres of non-treatment wetland area during recharge operation.</p>	<p>Once constructed the facility provides a habitat for various birds and waterfowl that also provides an opportunity for the public to view the birds. The Project will reduce groundwater pumping lifts and resulting energy savings. The savings will be shared with municipal and private well owners alike.</p>
112_SWID	Conjunctive use/recharged groundwater	Shafter Wasco Irrigation District	Shafter-Wasco Irrigation District Recharge Project	The Project will consist of up to seven 20-acre storm water recharge basins which total approximately 140 acres on property to be selected within a 4,000-acre survey area located within the Shafter-Wasco Irrigation District, Kern County, CA. The SWID Recharge Project is located within the Shafter-Wasco Irrigation District Boundaries, to the northeast of Shafter, CA, and on the west bank of the Calloway Canal at the corner of Beech and Fresno Avenues.	Poso Creek	35.551041 / -119.293969	<p>Improved overall water supply, water supply reliability, energy savings and reduced greenhouse gas emissions will result from the long-term increase in groundwater elevations in the Project area due to recharge of storm water. Therefore, although the Project will be operated as a groundwater storage facility with groundwater elevations increasing during periods when water is recharged and declining when groundwater is extracted for beneficial uses, the Project will be operated so as to maintain average groundwater elevations that are higher than they would be absent the Project. Supporting local groundwater levels will aid in regional compliance with the Sustainable Groundwater Management Act and will enable groundwater pumpers (both Project proponents and local domestic, agricultural and municipal users) to reduce pumping costs and lessen the need to deepen wells. The 140 acre recharge ponds are anticipated to absorb 0.5 acre-feet per day, or 70 AF per Day for up to 6 months, 4 out of 10 years. The equates to an average annual amount of 5,040 AF = [70 AF * 30 days * 6 months * 4] / 10. In addition, converting the land from irrigation to recharge ponds removes 490 AFY of demand = 140 A * 3.5 AFY/A demand. The project creates 5530 AF average annual yield (5040+490). Annual yield of supply: Average year 5,040 AF; Dry year 490 AF; Wet year 13,090 AF</p>	<p>The Project protects water quality in that storm water captured by the Project originates from uplands that form the watersheds of the lakes and reservoirs that will release water recharged by the Project. These source waters are largely unimpaired, with unsubstantial water quality issues. While flood releases conveyed overland and through unlined canals and river channels may mobilize substantial sediment loads, because the path of the storm water will not cross major urban or agricultural areas, with the exception of sediment, loadings of constituents other than sediment are expected to be low and will remain stable over time. 140 acres will be converted to recharge ponds.</p>	<p>The Project helps water infrastructure systems adapt to flood flows by alleviating pressure on an aging system. Existing research on climate change suggests that one of the primary outcomes will be a shift in snowfall to rainfall and an increase in peak storm flows. Providing an outlet for storm water flows that channels these flows to groundwater recharge facilities improves the functionality of existing infrastructure by diverting storm water flows from overtaxed conveyance channels during large storm events, and enhancing water supply reliability during dry years. Maximum volume of transitory storage of storm water runoff: 70 AF/day; 2100 AF/month</p>	<p>During periods when storm water is available for recharge, the spreading ponds will act as intermittent wetlands that will benefit wildlife including migratory birds. Creates 140 acres of non-treatment wetland area.</p>	<p>As noted in the water supply benefit section, recharging the groundwater aquifer provides a benefit to the local community by helping to increase the groundwater table elevation and lower the required pumping lift near the project. Therefore, all wells providing water for public or private use receive a benefit. The quantitative benefit of the project will be determined as design details are finalized. The construction of the recharge site provides some temporary employment. Creates bird viewing area for the community.</p>

## 5.4 Project Scoring Form – Description of Scoring Methodology

In order to demonstrate the Plan’s ability to implement storm water and dry weather capture projects, projects submitted must satisfy specific water management objectives and be able to deliver multiple benefits. Each project must identify at least two Main Benefits and as many Additional Benefits as possible. The quantification of benefits and analysis of proposed projects were evaluated using metrics for the five Main Benefit areas: Water Quality (WQ), Water Supply (WS), Flood Management (FM), Environmental (Env), and Community (Comm). A simple scoring methodology was developed for scoring and ranking projects. The projects and their preliminary rankings were submitted to the two IRWMP groups as part of the draft Plan. Stakeholders were allowed to provide comments during a public comment period and at Public Meeting No. 2.

### 5.4.1 Main and Additional Benefits Scoring

The following metrics were considered to evaluate how well proposed projects are able to deliver Main and Additional Benefits shown on pages 22-23 of the SWRP Guidelines:

#### 5.4.1.1 Effects of Proposed Projects on WATER QUALITY

- How do projects comply with or are consistent with existing NPDES permits?
- Description of watershed-based outcomes using modeling, calculations, pollutant mass balances, water volumes balances, or other methods of analysis
- Description of how projects will contribute to the preservation, restoration, or enhancement of watershed processes
- Include projects in a summary matrix/table with scoring metrics
- WQ metric: Pollutant load reduction (lbs/day, mg/L, bacteria count per ml, etc)
- WQ metric: Volume treated (mgd, AF/yr)

#### 5.4.1.2 Effects of Proposed Projects on Local WATER SUPPLIES

- How do proposed projects capture, store, and use storm water and dry weather runoff to recharge or replace groundwater or offset water imports from the Delta?
- Include projects in a summary matrix/table with scoring metrics
- WS metric: Groundwater volume recharged or replaced or runoff volume captured (mgd, AF/yr)
- WS metric: Augmentation/replacement of water supply or reduced dependence on imported water (mgd, AF/yr)
- WS metric: Cost of water supply augmentation (\$/AF/yr)

#### 5.4.1.3 Effect of Proposed Projects on FLOOD MANAGEMENT

- Describe how project will reduce flood risk through reduction in stage, flood flows

- Describe how flood water will be captured to maximize and/or augment water supply
- Include projects in a summary matrix/table with scoring metrics
- FM metric: Reduction in flood risk (reduced flow in cfs, reduced stage in feet, reduced volume in AF)
- FM metric: Reduction in sanitary sewer overflows (flow in cfs or volume in cubic feet or AF)

#### 5.4.1.4 Effect of Proposed Projects on ENVIRONMENTAL AND COMMUNITY Benefits, including the creation and restoration of habitat, open space, parks, recreation in disadvantaged communities

- Narrative describing how each project will benefit the environment and/or community
- Include in a summary matrix/table with scoring metrics
- Env metric: Habitat improved or restored; wetland enhanced/created; urban green space created (acres); reduced energy use (MWH); re-establishment of natural hydrograph (flows in cfs or stage in ft); water temp improvements by reduction in temp (degrees)
- Comm metric: Enhanced or created recreation or public use areas (acres); community involvement (no. of people); jobs created (no.)

**Appendix C: Project Scoring Forms** shows proposed projects would receive a score of either a 4 or 5 in each Main Benefit category. If a Main Benefit is well-quantified and supported by numerical results of calculations or modeling, the project received a score of 5. For less well-quantified Main Benefits, a score of 4 was given, which indicated that the Main Benefit would be achieved in concept, but the actual quantification of the benefit is not well-defined. A proposed project would need a minimum score of 8 in order to be considered viable for inclusion in the Plan, as the guidelines state that at least two Main Benefits must be achieved for a project to be eligible for inclusion in the Plan for consideration of future grant funding. All 12 of the proposed projects contained at least two Main Benefits.

**Appendix C: Project Scoring Forms** also shows the full spectrum of Additional Benefits possible for proposed projects. Projects received scores in the Additional Benefits column of 3, 2, or 1, depending on how well the Additional Benefits were quantified. Well-quantified Additional Benefits with objective numerical results supported by calculation or modeling received a score of 3. Additional Benefits achieved, but with less well-quantified metrics or conceptually improved metrics received a score of 2. Additional Benefits achieved by good concepts but needing more information, received a score of 1.

### 5.4.2 Project Readiness Scoring

Practical factors were also considered in developing the scoring methodology for the proposed projects. The **Appendix C: Project Scoring Forms** contain a Project Readiness Checklist, and proposed projects were evaluated against five Project Readiness criteria:

1. Is the Project ready to implement (Yes=1), (No=0)?
2. Is the Project cost well defined (1) or just an estimate (0)?

3. Is the land currently owned by a public agency (1) or does it need to be acquired (0)?
4. Is the environmental permitting process complete (1) or not yet started (0)?
5. Does the agency have the funds available for the 50 percent local funding match (Yes=1), (No=0)?

Each Project Readiness criterion was scored with either 1 or 0 for a “yes” or “no” response. Partial credit (0.5) was given for each partially completed Project Readiness criterion. The Project Readiness checklist was useful in separating conceptual projects from those that were further along in the planning process or more shovel-ready.

A Project Scoring Form (**Appendix C: Project Scoring Forms**) was filled out for each of the 12 proposed projects submitted to the Plan. The combined scores of the 12 proposed projects are summarized in **Table 5-2** and ranked by combined Main/Additional Benefit and Project Readiness scores, which satisfies the guidelines’ requirement for presenting a prioritized list of proposed projects.

## 5.5 Prioritized List of Projects

**Table 5-2** consists of the prioritized list of the 12 proposed projects, which were received in June 2016 for inclusion in the Plan. They are ranked by their ability to deliver Main and Additional benefits as well as their Project Readiness for construction. The Plan can be updated periodically with submittals of future projects or revisions to existing projects, correlated to future rounds of implementation grant funding opportunities.

Table 5-2. Prioritized List of Projects

Prioritized List of Projects							
Ranking	Sponsor Designator & Project No.	Type of Project	Project Sponsor	Project Name	Scoring		Stakeholder Comments
					Benefits	Readiness	
1	109_RRBWSD	Conjunctive use/recharged groundwater	Rosedale-Rio Bravo Water Storage District	Stockdale East Groundwater Recharge Project	21	2	
2	108_BVWSD	Conjunctive use/recharged groundwater	Buena Vista Water Storage District	The Palms Storm Water Recharge and Recovery Project	18	3	
3	104_SWSD	Conjunctive use/recharged groundwater	Semitropic Water Storage District	Entrance Ponds to the Pond Poso Spreading Grounds	18	2	
4	112_SWID	Conjunctive use/recharged groundwater	Shafter Wasco Irrigation District	Shafter-Wasco Irrigation District Recharge Project	17	2.5	
4	111_RRBWSD	Groundwater banking	Rosedale-Rio Bravo Water Storage District	James Groundwater Storage and Recovery Project	17	2.5	
5	103_SWSD	Groundwater banking	Semitropic Water Storage District	Stored Water Recovery Unit, Element of the Semitropic Groundwater Bank	17	2	
6	110_RRBWSD	Storm water conveyance to recharge facility	Rosedale-Rio Bravo Water Storage District	Western Rosedale In-Lieu Service Area Project	16	2.5	
7	101_SWSD	Conjunctive use/recharged groundwater	Semitropic Water Storage District	Schuster Spreading Grounds	16	1	

Section Five: Identification and Prioritization of Projects  
Kern County Storm Water Resource Plan

Prioritized List of Projects							
Ranking	Sponsor Designator & Project No.	Type of Project	Project Sponsor	Project Name	Scoring		Stakeholder Comments
					Benefits	Readiness	
8	102_SWSD	Conjunctive use/recharged groundwater	Semitropic Water Storage District	Pond-Poso Spreading Grounds, Phase 2	15	2	
9	105_KC	Habitat mitigation and groundwater recharge	County of Kern—Public Works Department	Caliente Creek Habitat Restoration and Groundwater Recharge Projects—Design and Construction	13	0.5	
10	107_KC	Detention basin/groins/grade control structures/bank armoring	County of Kern—Public Works Department	Sandy Creek Bank and Erosion Protection Project	12	0	
11	106_KC	Habitat restoration and streambank stabilization	County of Kern—Public Works Department	Cuddy Creek Restoration Project	11	1.5	

## 5.6 Process for Submitting New or Modifying Existing Project Proposals

One of the goals of the Plan is to make it a living document capable of adapting to changing watershed conditions and be receptive to submittal of new projects and modifications to existing projects. At the time of publication, there were 12 proposed projects submitted, all of which are included in the Plan. There are many districts within the Poso Creek and Kern Regional Water Management Groups that did not submit proposals due to budget or time constraints. This Plan is designed to accommodate and not discourage later proposal submissions. This section describes the process for submitting new project proposals or revising existing project proposals.

### 5.6.1 New Project Proposals

If an agency or stakeholder wishes to submit a new project for consideration, the first step is to fill out a PSF. A blank PSF template is included in **Appendix A: Project Submittal Form Template**. Fill out the form with as much detail as possible. Include metrics supported by calculation, models, or measurements, such as those included in **Section 5.4**. Quantify the Main Benefits and Additional Benefits provided by the new project proposal and show how the new project provides Main Benefits and Additional Benefits. A project proposal must include at least two Main Benefits and as many as possible Additional Benefits. The proposal should then be submitted to the IRWMP group most closely associated with the project location.

### 5.6.2 Modifications or Revisions to Existing Project Proposals

If an agency or stakeholder wishes to submit modifications or revisions to an existing project, which has already been adopted into the Kern SWRP, the stakeholder would fill out a PSF and attach the previously submitted PSF to the new form. A blank PSF template is included in **Appendix A: Project Submittal Form Template**. Fill out the new form with as much detail as possible. Include metrics supported by calculation, models, or measurements, from the list included in **Section 5.4**. Quantify the Main Benefits and Additional Benefits provided by the revised project proposal and show how the revised project improves or expands upon the Main Benefits and Additional Benefits of the previously adopted project. The revised proposal should then be submitted to the same IRWMP group associated with the project location as on the originally submitted PSF.

Table 5-3. IRWMP Group Contacts for Project Submittals

IRWMP Group Contacts for Project Submittals	
Group	Contact
Kern IRWMP Group	Email: <a href="mailto:KernIRWMP@kcwa.com">KernIRWMP@kcwa.com</a>
Poso Creek IRWMP Group	Ms. Isela Medina, PE Semitropic Water Storage District Address: PO Box 8043, Wasco, CA 93280; 1101 Central Avenue, Wasco, CA 93280 Telephone: (661) 758-5113; Fax: (661) 758-3219; Email: <a href="mailto:imedina@semitropic.com">imedina@semitropic.com</a>



# 6 Implementation Strategy and Schedule

## 6.1 Resources for Plan Implementation

The Kern Storm Water Resources Plan is being funded by the Buena Vista Waster Storage District and the Shafter-Wasco Irrigation District. The Plan implementation costs moving past the initial development of the plan will be funded by the Project Sponsors identified in **Section 5**.

Potential Project Sponsors' will provide the appropriate local matching funds through a variety of potential resources. A list of available funding sources, in addition to Sponsors' general funds, is identified below. Many of the funding sources listed below can be found in the Kern County and Poso Creek IRWMP.

### 6.1.1 Project Funding

Securing funding for the projects proposed in the Kern SWRP can be best accomplished with a focused, deliberate, packaging strategy. As seen from the descriptions below, there are many funding programs within and outside of the Kern Region that could provide financial opportunities for the Sponsors' projects. As these funding opportunities become available, Plan Projects will be integrated to fit the funding criteria. In this manner, a process would be established for integrating packages of projects for future funding programs.

Grant and loan funding sources have been identified based on currently available information. However, due to the uncertainty of the State of California's budgets, the availability of many grant and loan programs are never guaranteed. Grant and loan programs dependent on the sale of California General Obligation bonds have been, and will very likely will continue to be, limited in the amount of funding offered. This section includes a discussion of funds available through various grant programs and specifies eligibility requirements. Although some of the programs listed below may not be directly related to storm water projects, the Plan Projects may still have a nexus to these funding programs, warranting the Project Sponsor to consider submitting an application to a funding program.

#### 6.1.1.1 State Funding Programs

##### 6.1.1.1.1 Storm Water Grant Program (SWRCB)

The SWRCB provides grant funds for multi-benefit storm water management projects through the Proposition 1 Storm Water Grant Program. Proposition 1 designated \$200 million in grant funds for projects that improve regional water self-reliance, security, and adapt to the effects on water supply arising from climate change. Storm water and dry weather runoff are underutilized sources of water supplies and may cause pollution or impairment of rivers, lakes, streams, and coastal waters. The SWGP will fund projects that have multiple benefits including water supply, flood control, habitat enhancement/restoration, and creating green spaces.

The SWGP has two types of grants available: Planning Grants and Implementation Grants. The Planning Grant had one funding round of \$19 million (occurred in Spring 2016) that will be used for developing SWRPs and planning for specific projects throughout the state. Two rounds of Implementation Grant funding have been designated under Proposition 1. Approximately \$80 million of funding is designated for Round 1 in 2016, and \$100 million is designated for Round 2 that will occur in 2018. Implementation Grant awards can range from \$250,000 to \$10,000,000 per project. The local funding match is set at 50 percent of the project cost with reductions available for DACs or Economically Distressed Areas (EDAs).

#### *6.1.1.1.2 Integrated Regional Water Management Implementation Grants (DWR)*

The DWR is the state agency responsible for overseeing the IRWM programs statewide, which includes administering the Proposition 1 IRWM Grant Program, which provides funding for projects that help meet the long term water resource needs within IRWM Regions. Kern and Poso Creek IRWM agencies have obtained grant monies to fund projects in previous years through Proposition 50 and 84 funding. Proposition 1 designates \$510 million for IRWM grant funding; \$34 million is available for the Tulare/Kern funding area, where the Kern and Poso Creek IRWM regions are located. The first round of Proposition 1 implementation grant funding is expected to begin in 2018. Criteria for obtaining Proposition 1 grant funds include: assisting water infrastructure systems to mitigate impacts from climate change; providing incentives throughout each watershed to collaborate in managing a region's water resources and setting regional priorities for water infrastructure; and improving regional water self-reliance, while reducing reliance on Sacramento-San Joaquin Delta. Plan Projects are required to be included in their respective IRWMP and may be eligible for potential funding.

<http://www.water.ca.gov/floodmgmt/funding/small-communities.cfm>

#### *6.1.1.1.3 Federal 319 Program (SWRCB)*

This program, administered by the SWRCB, is a NPS pollution control program that is focused on controlling activities that impair beneficial uses and on limiting pollutant effects caused by those activities. The program is federally funded on an annual basis. Project proposals that address TMDL implementation and those that address problems in impaired waters are favored in the selection process. There is also a focus on implementing management activities that reduce and/or prevent release of pollutants that impair surface and ground waters. Nonprofit organizations, local government agencies including special districts, tribes, and educational institutions qualify. State or federal agencies may qualify if they are collaborating with local entities and are involved in watershed management or proposing a statewide project.

#### *6.1.1.1.4 Water Recycling Funding Grant and Loan Program (SWRCB)*

This is a long-term program operated by the SWRCB that offers grants and low-interest loans for the planning, design and construction of water recycling facilities. This program can also be used to fund groundwater recharge facilities for indirect potable reuse (IPR). Grants are provided for facilities planning studies to determine the feasibility of using recycled water to offset the use of fresh/potable water from state and/or local supplies. Pollution control studies, in which water recycling is an alternative, are not eligible. Public agencies and privately-owned utilities regulated by the California Public Utilities Commission (CPUC) are eligible. The Water Recycling Funding Program receives funding from various sources, including Proposition 1 and the State Revolving Fund (SRF). Due to the varying funding sources, preferences for funding can vary.

#### *6.1.1.1.5 Clean Water State Revolving Fund (SWRCB)*

The Federal Water Pollution Control Act (Clean Water Act or CWA), as amended in 1987, provides for establishment of a Clean Water State Revolving Fund (CWSRF) program. The program is funded by federal grants, state funds (including Propositions 50, 84, and 1), and revenue bonds. The purpose of the CWSRF program is to implement the CWA and various state laws by providing financial assistance for the construction of facilities or implementation of measures necessary to address water quality problems and to prevent pollution of the waters of the State.

The CWSRF Loan Program provides low-interest loan funding for construction of publicly-owned wastewater treatment facilities, local sewers, sewer interceptors, water recycling facilities, as well as, expanded use projects such as implementation of NPS projects or programs, development and implementation of estuary Comprehensive Conservation and Management Plans, and storm water treatment. Publicly owned treatment works, local public agencies, non-profit organizations, and private parties are eligible for funding. Matching funds are not required. Applications are continuously accepted and \$200 to \$300 million is available annually.

#### *6.1.1.1.6 Infrastructure State Revolving Fund- California Infrastructure and Economic Development Bank*

Through I-Bank, this program funds public infrastructure projects deemed important to California communities. The financing is available to cities, counties, special districts, assessment districts, joint powers authorities, and redevelopment agencies. Eligible projects may include streets and highways, sewage collection and treatment, water treatment and distribution, drainage, flood control, solid waste collection and disposal. The financing can be paired with other grant and loans programs to complete the funding of a project although no matching is required and the funds may serve as the sole source for the project.

#### *6.1.1.1.7 Safe Drinking Water State Revolving Fund (DDW)*

The Federal Safe Drinking Water Act (SDWA) Amendments of 1996 authorized the creation of a revolving fund program for public water system infrastructure needs specific to drinking water. There is similar state legislation and the Safe Drinking Water State Revolving Fund (SDWSRF) reflects the intent of federal and state laws to provide grant funding or low-interest loans to correct deficiencies in public water systems based on a prioritized system. Highest priority is given to projects that address public health risk, projects that will assist a public water system with compliance with the SDWA, and projects that assist those public water systems most in need. Funding is available for construction/ enhancement of public water systems. The program is funded by federal grants, state funds (including Propositions 50 and 84), and revenue bonds. The program is administered by the SWRCB Department of Drinking Water (DDW). The entity must be a public water system to be eligible and preference is given to DACs.

#### *6.1.1.1.8 Agricultural Drainage Loan Program (SWRCB)*

The Agricultural Drainage Loan Program was created by the Water Conservation and Water Quality Bond Law of 1986 to address treatment, storage, conveyance, or disposal of agricultural drainage water that threaten waters of the State.

#### *6.1.1.1.9 Agricultural Water Use Efficiency Program (DWR)*

This grant program will fund agricultural water use efficiency projects. This particular water use efficiency Guidelines and Proposal Solicitation Package (PSP) directly supports California Water

Plan - Action Number One: Make Conservation a California Way of Life, as well as supporting several other Actions, either directly or indirectly. Funding through this program is also directed towards agricultural water management planning and water use efficiency projects and programs developed pursuant to Part 2.8 (commencing with Section 10800) of Division 6 of the California Water Code.

<http://www.water.ca.gov/wuegrants/SolicitationsProp1AG.cfm>

### 6.1.1.2 Federal Funding Programs

#### 6.1.1.2.1 *WaterSMART (USBR)*

The USBR Sustain and Manage America's Resources for Tomorrow Program (WaterSMART) was established for USBR to work with states, tribes, local governments, and NGOs to secure and stretch water supplies for use by existing and future generations. In addition to sustainable water resources goals, the program also addresses adaptive measures needed to address climate change and future demands. The programs described below are part of the WaterSMART program.

#### 6.1.1.2.2 *Water and Energy Efficiency Grants (USBR)*

The Water and Energy Efficiency Grants program offered through USBR is an annual grant program which the applicant will need to provide a minimum of a 50 percent match. The projects need to demonstrate both water and energy savings.

#### 6.1.1.2.3 *Grants to Develop Climate Analysis Tools (USBR)*

These grants, offered annually, provide funding to universities, non-profits, or entities with water or energy delivery authority in the Western United States for the development of tools to better manage water resources with the caveat the tool must consider climate change. Seven areas of research are listed as eligible under this program which the ultimate goal of better water resource management.

#### 6.1.1.2.4 *Advanced Water Treatment Grants (USBR)*

The Advanced Water Treatment (ADWT) Grant Program offered by USBR funds demonstration and pilot projects which utilize advanced water treatment systems. The purpose of this program is to create a new economically feasible water supply from brackish groundwater, seawater, or impaired waters. The ADWT grant encourages water agencies to accelerate the adoption of advanced water technologies including reverse osmosis, filtration, electrodialysis, pretreatment methods, advanced oxidation, concentrate disposal or any other process that removes dissolved and suspended matter such as salts, viruses, bacteria or any other difficult to remove matter. The projects should not be the full scale plant but a pilot to demonstrate the viability of the project. Operations and maintenance (O&M) costs are not included in the funding, cost sharing is required, and the projects must be completed within the specified timeframe of the grant.

#### 6.1.1.2.5 *Cooperative Watershed Management Program (USBR)*

The Cooperative Watershed Management Program provides funding for Phase II watershed management projects in fiscal year 2017. Phase II funding will support local watershed groups in implementing collaborative solutions to water management issues. USBR is seeking comments on the draft criteria and eligible project types.

*6.1.1.2.6 Drought Resiliency Project Grants and Drought Contingency Planning Grants (USBR)*

The Program establishes a framework to provide federal leadership and assistance for using water efficiently, integrating water, and energy policies to support the sustainable use of all natural resources, and coordinating the water conservation activities of various U.S. Department of the Interior (DOI) bureaus and offices. Through the program, the DOI is working to achieve a sustainable water strategy to meet the nation's water needs. The objective of this Program is to invite states, tribes, irrigation districts, water districts, and other organizations with water or power delivery authority to leverage their money and resources by cost-sharing Drought Contingency Planning with USBR to build resilience to drought in advance of a crisis.

*6.1.1.2.7 Title XVI Feasibility Studies (USBR)*

The objective of this Program is to invite applicants to submit proposals to develop new Title XVI feasibility studies. Applicants must provide 50 percent non-federal cost share for the proposed activity. Under Title XVI of Public Law 102-575, USBR works to identify and investigate opportunities to reclaim and reuse wastewaters and naturally impaired ground and surface water in the 17 Western States and Hawaii. Title XVI also provides authority for USBR to provide up to 50 percent of the costs of studies to determine the feasibility of water reclamation and reuse projects. Prior to construction funding of any project authorized under Title XVI, USBR must determine that a feasibility study for the project complies with the provisions of Title XVI. Under this Program, funding is being made available to assist project sponsors with the development of new Title XVI feasibility studies.

*6.1.1.2.8 FEMA/California Emergency Management Agency Infrastructure Improvement Grants*

FEMA, through the California Emergency Management Agency, funds grants to improve existing infrastructure to increase protection from hazards (such as wildfires, earthquakes, etc.). The intent is to improve infrastructure, particularly lifeline infrastructure (water systems, hospitals, fire) to reduce injuries, loss of life, and damage and destruction of property. Grants are also available for the creation of Local Hazard Mitigation Plans.

*6.1.1.2.9 North American Wetlands Conservation Act Grant (USFWS)*

This grant provides funds for projects that provide long-term protection of wetlands, and the fish and wildlife that depend upon wetlands. Applicants must provide local match equal to that requested. Entities that are eligible include organizations and individuals who have developed partnerships to carry out wetlands conservation projects in the U.S., Canada, and Mexico. Applications are continuously accepted by the USFWS for this grant.

*6.1.1.2.10 Environmental Protection Agency, Pollution Prevention (EPA)*

The EPA created the Pollution Prevention (P2) Grant Program (formerly Pollution Prevention Incentives for States) under the authority of the Pollution Prevention Act of 1990. The grant program provides matching funds to state and tribal programs to support P2 activities across all environmental media and to develop state-based programs. The purpose of the P2 Grant Program is to give states and tribes the capability to assist businesses and industries in identifying better environmental strategies and solutions for complying with federal and state environmental regulations. It also aims to improve business competitiveness without increasing environmental impacts. The majority of P2 Grants fund state-based projects for technical assistance, training,

outreach, education, regulatory integration, data collection, research, demonstration projects, and recognition programs.

*6.1.1.2.11 Environmental Protection Agency, Source Reduction Assistance (EPA)*

The EPA annually awards grants and cooperative agreements under the Source Reduction Assistance (SRA) Grant Program. The purpose of this program is to prevent the generation of pollutants at the source and ultimately provide an overall benefit to the environment. This program seeks projects that support source reduction, pollution prevention, and/or source conservation practices. Source reduction activities include: modifying equipment or technology; modifying processes or procedures; reformulating or redesigning products; substituting raw materials; and generating improvements in housekeeping, maintenance, training, or inventory control. Pollution prevention activities reduce or eliminate the creation of pollutants via such procedures as: using raw materials, energy, water or other resources more efficiently; protecting natural resources through conservation; preventing pollution; and promoting the reuse of materials and/or conservation of energy and materials. Eligible organizations include units of state, local, and tribal government; independent school district governments; private or public colleges and universities; nonprofit organizations; and community-based grassroots organizations.

*6.1.1.2.12 Environmental Protection Agency, Wetlands Program Development Grants (EPA)*

This program seeks projects that promote the coordination and acceleration of research, investigations, experiments, training, demonstrations, surveys, and studies relating to the causes, effects, extent, prevention, reduction, and elimination of water pollution. The EPA has identified three priority areas: (1) the development of a comprehensive monitoring and assessment program; (2) the improvement of the effectiveness of compensatory mitigation; and (3) the refinement of the protection of vulnerable wetlands and aquatic resources. Eligible entities include states, tribes, local governments, interstate associations, intertribal consortia, and national non-profit, NGOs.

*6.1.1.2.13 Natural Resources Conservation Service, Watershed Protection and Flood Prevention Grant (NRCS)*

The purpose of the program is to support activities that promote soil conservation and that promote the preservation of the watersheds of rivers and streams throughout the U.S. This program seeks to preserve and improve land and water resources via the prevention of erosion, floodwater, and sediment damages. The program supports improvement of: (1) flood prevention including structural and land treatment measures; (2) conservation, development, utilization, and disposal of water; or (3) conservation and proper utilization of land. Successful applicants under this program receive support for watershed surveys and planning, as well as watershed protection and flood prevention operations. Funding for watershed surveys and planning is intended to assist in the development of watershed plans to identify solutions that use conservation practices, including nonstructural measures, to ultimately solve problems.

Matching funds are not required; however, applicants must generally provide matches ranging from 0 to 50 percent in cash or in-kind resources depending on such factors as project type and the kinds of structural measures which a project proposes.

Eligible entities include: states, local governments, and other political subdivisions; soil or water conservation districts; flood prevention or control districts; and tribes. Potential applicants must be

able to obtain all appropriate land and water rights and permits to successfully implement proposed projects.

#### *6.1.1.2.14 Water and Waste Disposal Program (USDA)*

The Water and Waste Disposal Program provides financial assistance in the form of grants and loans for the development and rehabilitation of water, wastewater, and storm drain systems within rural communities. Funds may be used for costs associated with planning, design, and construction of new or existing water, wastewater, and storm drain systems. Eligible projects include storage, distribution systems, and water source development. Projects must benefit cities, towns, public bodies, and census-designated places with a population less than 10,000 persons. The intent of the program is to improve rural economic development and improve public health and safety.

#### *6.1.1.2.15 Rural Development Program (USDA)*

The U.S. Department of Agriculture (USDA), through its Rural Development Program, offers grants and financing for utilities in communities of less than 10,000 persons. Public agencies and Native American tribes are eligible grantees. Eligible utilities include electric, telecommunications, water, and environmental (wastewater, solid waste, storm drainage).

#### *6.1.1.2.16 Rural Water Supply Program (USBR)*

Through this program, USBR assists rural communities in the western United States with planning and design of projects to develop and deliver potable water supplies. Public agencies and Native American tribes serving communities of less than 50,000 persons are eligible to receive funding for appraisal investigations and feasibility studies related to water supply.

#### *6.1.1.2.17 Agricultural Water Conservation Grants (USBR)*

The USBR and the Natural Resources Conservation Service (NRCS) collaborate to make federal funding available in California to improve the efficiency of agricultural water use throughout the state. The projects funded through this partnership are intended to help communities build resilience to drought, including the modernization of their water infrastructure and efficiently using scarce water resources, while supporting the agricultural economy. USBR has the authority to provide financial assistance to entities with water or power delivery authority, including water districts and irrigation districts, whereas NRCS has the authority to provide on-farm assistance.

#### *6.1.1.2.18 San Joaquin River Restoration Program Part III of Title X (USBR)*

The San Joaquin River Restoration Program provides financial assistance to local agencies within the CVP of California for the planning, design, environmental compliance, and construction of local facilities to bank water underground or to recharge groundwater to reduce, avoid, or offset the quantity of expected water supply impacts to Friant Division long-term contractors caused by the interim and restoration flows.

## **6.2 Implementation**

The beneficiaries of the Kern SWRP are the residents of the Kern Region represented by the Plan stakeholders, and include: water agencies; local, state, and federal agencies; NGOs, businesses, wildlife organizations, the agricultural/farm industry, and others within the Kern SWRP Region. The

Plan will, through project implementation, ensure regional multiple benefits. Projects included in this Plan are discussed in **Section 5**. The funding sources briefly discussed in the section above will help ensure the Plan is implemented.

As part of this Plan, a call was solicited to all stakeholders for projects to be submitted for inclusion in the Plan. Projects were analyzed and ranked within the SWRP (See **Section 5**). Comments were solicited for the Plan from all stakeholders. The projects identified within this Plan will be submitted through their respective IRWMPs for implementation.

### 6.2.1 SWRP Project Monitoring

The objectives and goals of the SWRP are stated in **Section 1**. These goals will be monitored as projects are implemented. The Kern SWRP was prepared using information and guidance provided by a mix of water suppliers, municipalities, regulatory, environmental, agricultural, and land use planning entities that represent all areas of the Kern Region. Extensive information and data on the Kern Region have been prepared by these various agencies and groups. The groups within Kern County, through the IRWMP process, submitted their plans, reports, and studies to the region's IRWMP resource library to ensure that the Kern IRWMP accurately reflects each stakeholder's individual perspectives, which was used during the development of this SWRP. That information was reviewed and evaluated and served as the technical foundation for the development of this plan. Refer to the Kern IRWMP Tables 14-1 through 14-4 for a listing of various plans, reports and studies pertinent to the area.

The use of these plans and the data collected by various agencies and committees within the Kern Region will aid in determining if specific SWRP projects are meeting monitoring goals and providing a benefit to the area. The Kern IRWMP details the data collection and monitoring for the Kern Region. Each of these committee's and/or agencies are collecting data that is important to the region, have methods for data collection that are similar, and thus have opportunities for streamlining or maximization of efficiencies for creating region-wide datasets and databanks.

Data is vitally important to agencies trying to maximize operating efficiency and design projects with limited budgets. The types of data available, current relevance and trends, and knowledgeable people that can interpret the data are all important. Equally important is the opportunity for federal and state agencies to view local data for their own monitoring needs and to better understand local conditions.

## 6.3 Adaptive Management

The SWRP was created utilizing public participation and assistance and feedback from various stakeholders in the Kern Region. The Plan was developed in order to provide a planning and regional benefit basis for water projects in Kern County. As the projects are developed or regional needs/benefits change, the SWRP will be revised to adequately address the needs of the area in the context of the SWRCB plan guidelines. Projects will be added to or removed from the SWRP through the submittal and review process, and added to the agenda of regularly-scheduled Kern and Poso Creek IRWMP meetings for consideration of inclusion in the Plan.



When the SWRP is re-opened for revisions, updates can be applied throughout the Plan. The Plan priorities, assessments, project ranking, project addition/removal, etc. will be addressed. The Plan can be re-opened/revised based on the procedure below. If the Plan is being re-opened for the sole purpose of including or removing projects, a process is identified in **Section 5.6**.

1. Adoption/Acceptance of the Kern SWRP:
  - a. To adopt/accept the Kern SWRP, the Stakeholders Group shall issue a notice to all participants in the respective IRWMPs of the intent to adopt/accept the Kern SWRP. A vote will be held, either in person, via mail or electronically. A list of entities or individuals that provided comments to the draft SWRP can be found in **Appendix E: List of Individuals and Entities that Provided Comments on Draft SWRP**.
  - b. The Kern SWRP shall be adopted/accepted when a majority of the stakeholders vote in favor of acceptance of the Plan.
    - i. Acceptance of the Plan by each entity seeking to do so shall be subject to the internal policies and practices of said entity.
2. Amendments to the Kern SWRP:
  - a. Amendments to the plan may be proposed by any member of the Stakeholder Group.
  - b. Amendments to the Plan shall require:
    - i. Approval of the stakeholders by a simple majority vote.
    - ii. The amended Plan shall be adopted/accepted when a majority of the stakeholders vote in favor of acceptance of the Plan.
  - c. Amendment of one or more of the appendices, in part or in whole, shall not require re-adoption of the Plan by the Stakeholder Group.

The Kern SWRP is anticipated to be revised prior to the release of the SWGP Round 2 final guidelines, which is tentatively scheduled for 2018.

# 7 Education, Outreach and Public Participation

## 7.1 Public Outreach and Participation Opportunities

Through public education and public participation communication efforts key stakeholders and community members will have the opportunity to be involved in actions and decisions regarding the implementation and design of watershed-based storm water management projects noted in this Plan (**Table 4-2**). Through these efforts, the goal will be to engage the public when considering major technical and policy issues related to the development and implementation of the Plan, engaging community members and key stakeholders who will be affected by project design and implementation. This section discusses the mechanisms, processes and milestones that will be used to engage and facilitate public participation and communication for projects.

### 7.1.1 Identifying Key Stakeholders

Key stakeholders that have been involved in plan development were identified as stakeholders of the Kern and Poso Creek RWMGs (**Table 4-1**). As the Kern SWRP is implemented, other specific stakeholders such as DACs and the residents of those communities will be brought into the communication process. DACs that will be directly affected by the projects included in this Plan are discussed in **Section 7.2**.

While the Kern RWMG and Poso Creek RWMG members and specific DACs are noted as the main stakeholders in the implementation of the Plan, additional parties may include developers, locally regulated commercial and industrial stakeholders, nongovernmental and nonprofit organizations (discussed in **Section 4.3**), and the overall general public. As projects come to fruition, these additional parties will be identified by the agencies/project proponents responsible for the project, and a point-of-contact will be researched and included in any communication distribution lists.

### 7.1.2 Public Outreach/Participation Actions

#### 7.1.2.1 Plan Development Communication

As described in **Section 4.5**, during the development phase of the Plan, key stakeholders were identified as members of the Kern and Poso Creek RWMGs (**Table 4-1**) and were invited to attend and participate in public meetings and contribute storm water-related project proposals to be included in the Plan. The initial meeting was held on May 31, 2016 at the Shafter-Wasco Irrigation District office, and the presentation consisted of the purpose and need for a SWRP, an overview of the Kern SWRP outline, review of the Project Submittal Form, an announcement regarding the second public meeting to be held in the fall, and a period of questions and general discussion.

A second public meeting was held with stakeholders on November 9, 2016 at the Buena Vista Water Storage District office to review and discuss the draft Kern SWRP, which was distributed by email

and posted online at [www.kernirwmp.com](http://www.kernirwmp.com) for a three-week public review period on October 21, 2016. The meeting's primary focus consisted of an overview and corresponding discussion with stakeholders of any necessary additions or revisions for each of the seven SWRP sections.

### 7.1.2.2 Plan Implementation Communication

As the projects listed in the Plan are funded through grant programs and begin their implementation phase (planning, design, and construction), the affected agencies, surrounding landowners, and directly-affected community members will be included in a communication plan regarding the projects. The following are suggested outreach mechanisms to engage stakeholders during project planning, design and implementation phases:

#### 7.1.2.2.1 Direct Community Outreach

- **Educational Public Meetings** – Public meetings would be held as necessary, specifically when the project involves/affects a DAC and/or directly impacts landowners and ratepayers of the responsible district(s). A minimum of two meetings are suggested; however, more can be held if determined to be necessary:
  - The first meeting would discuss an overview of the project including what the final goal would be and how it would benefit the stakeholders including anticipated long and short term solutions provided by the completed project that would address water-related challenges they may be facing; beginning discussions with stakeholders to determine their needs and concerns regarding the project; communicating the “what’s next” process as far as education efforts and project progression; and an opportunity for questions and answers.
  - The second (and any additional) educational public meeting(s) should consist of updates on the progress of the project; an overview of the information gathered from any surveys conducted and how the gathered input is being incorporated into the project phases to best suit the short and long-term needs of the stakeholders; and an opportunity for questions and answers. Additional agenda items may be added as needed.

Attendance at the meetings should be taken to track participants and to follow-up on any specific questions or issues that may come up in discussions.

- **Community/Stakeholder Surveys** – Community/stakeholder surveys may be utilized to gather additional information, particularly from landowners and DAC community members as a follow-up to the initial public meeting.
  - Landowner surveys can be easily developed using an online survey source such as Constant Contact or Google Forms, and instructions and a link to the survey can be distributed by email by the responsible district(s) or public outreach consultant.
  - Community members within the affected DACs may not have Internet access or it may be more difficult to gather email addresses, therefore door-to-door surveys may be the best way to ensure the information is gathered from the intended audience. These surveys should be provided in English and Spanish versions, and a Spanish interpreter should be part of the team conducting door-to-door surveys in order to alleviate any potential language barriers.

#### 7.1.2.2.2 Printed Communication

- **Branding** – To help with all methods of communication, it is best that a “brand” be developed for the project to help recipients of information with recognition and immediate association with a project. Branding can be established through methods such as the development of a logo for the project, and consistent usage of fonts and a graphical image.
- **Printed Materials** – Printed materials should incorporate the visual imagery established through branding efforts, and should be tailored for specific means of communication:
  - Fliers – Fliers can be designed and distributed either via direct mail and email, or printed and distributed in communities. In some cases, the fliers should be both in English and Spanish languages.
  - Letter Correspondence – Letters can be distributed via email or direct mail and can include specifics on project information, such as construction schedules, the need for the completion of a survey, and other pertinent facts to be communicated to stakeholders.
  - Presentation Materials – A Power Point presentation may be utilized at the public meetings. If a Power Point isn’t possible to display for a meeting, display boards printed at 24-inch x 36-inch or larger size can be used and set up on easels. Handouts of presentations and smaller versions of display boards can be distributed to meeting attendees, and later emailed (or posted on a website) for access by stakeholders as a recap of a meeting (as discussed in **Section 7.1.2.2.3**).
- **Signage** – If projects are funded by specific grants such as Proposition 1, then projects should be kept in compliance with Water Code section 79707(g), as these projects must include signage informing the public about that the project.

#### 7.1.2.2.3 Digital Communication

- **Websites** – Public meeting notices, agendas and minutes, PDFs of meeting presentations, and any handouts related to the SWRP will be posted on the Kern IRWMP ([www.kernirwmp.com](http://www.kernirwmp.com)) and Poso Creek IRWMP ([www.semitropic.com/PosoCreekIRWM.html](http://www.semitropic.com/PosoCreekIRWM.html)) websites in a timely manner.  
  
Project specific communication would occur through the implementing agency’s website. Printed materials, community/stakeholder surveys and completion instructions, educational fliers and any other methods of printed communication would also be posted (in both English and Spanish versions as necessary).
- **Email Distribution** – Members of the Kern and Poso Creek IRWM will be communicated with via email as upcoming public meetings regarding the SWRP are scheduled. Emails to these groups can be made through the specific IRWM managers.
- **Press Releases** – As needed, press releases may be written and distributed to a media list that consists of media outlets (newspapers, radio and television stations) within Kern County. Press releases should cover the “who, what, why, when and where” for pertinent information the public should be aware of regarding the projects included in this Plan. Press release topics should include: upcoming public meeting information; requests for

completion of community/stakeholder surveys; construction schedules; and any other important project information.

## 7.2 Involvement of Disadvantaged and Climate Vulnerable Communities

DAC involvement will be integrated as the Plan is implemented and projects within or adjacent to DACs begin to come to fruition. A composite listing of DACs within the Kern and Poso Creek IRWM boundaries are listed on **Table 4-4**. The specific disadvantaged and climate-vulnerable communities that may be affected by storm water projects and will need to be included in the implementation of the Plan are noted in **Table 7-1**:

**Table 7-1. DACs Affected by Potential Projects**

DACs Affected by Potential Projects			
DACs Involved	Implementing Agency/Organization	Potential Project	Location to DAC Boundary
Community of Arvin	County of Kern – Public Works Department	Caliente Creek Habitat Restoration and Groundwater Recharge Projects (Design & Construction)	Adjacent
Community of Lamont/Lamont Storm Water District			
Frazier Park	County of Kern – Public Works Department	Cuddy Creek Restoration Project	Within, Adjacent
City of Taft	County of Kern – Public Works Department	Sand Creek Bank and Erosion Protection Project	Within, Adjacent
Ford City			
City of Buttonwillow	Buena Vista Water Storage District	The Palms Storm Water Recharge and Recovery Project	Adjacent
City of Taft			
Community of Tupman			

### 7.2.1 Communicating with and Educating DACs

Communication with DACs is essential to the successful completion of watershed-based storm water management projects, and residents are generally dedicated to bettering their communities. Important information that will be essential to communicate to and engage DACs will include construction timelines, benefits to their communities, and soliciting information from community members such as how design/functionality/environmental factors could impact their quality of life, and short and long-term solutions.

Opportunities to educate the members of DAC communities and gather their input may be conducted via door-to-door community surveys, educational materials (posters, hand outs, letters, etc.) to educate residents about goals of the Plan and specific project and conservation efforts they can implement in their daily tasks, and public outreach meetings. All materials should be available in English and Spanish languages. In addition, a Spanish interpreter will be available to translate at any community meetings and while conducted door-to-door surveys (if needed).

By including the DAC members, they will have a sense of ownership in the project and more likely to participate and provide feedback that could be crucial to long-term solutions that projects should solve. Engaged community members will be tracked using a sign-in system at any public meetings held, as well as responses received from community surveys and any other correspondence with community members regarding the specific project.

### 7.3 Addressing Environmental Injustice Issues

By including DACs in the implementation process of projects listed in the Plan that are within and/or adjacent to their boundaries with direct impact on their communities, runoff-related environmental injustice can be avoided, or at the very least, minimized. With the involvement of these communities in the planning process, project aspects that could negatively affect residents' quality of life can be identified immediately so that short and long term solutions can be incorporated into final designs and project implementation. Opportunities to educate the members of DAC communities and gather their input will be conducted via door-to-door community surveys, informational materials (posters, handouts, letters), and community meetings. All materials will be available in English and Spanish languages, and both versions of all materials will be posted on the Kern and Poso Creek IRWMP websites. In addition, a Spanish interpreter will be available to translate at any community meetings held. Methods of communication are described in greater detail in [Section 7.1.2](#).

### 7.4 Public Engagement and Education Schedule

Schedules for public engagement and education efforts will vary by project.

# 8 SWRP Checklist and Self-Certification

## 8.1 Checklist Instructions

For each element listed below, review the applicable section in the Storm Water Resource Plan Guidelines and enter ALL of the following information.

- A. Mark the box if the Storm Water Resource Plan, or a functional equivalent Plan, meets the provision
- B. In the provided space labeled References, enter:
  1. Title of document(s) that contain the information;
  2. The chapter/section, and page number(s) where the information is located within the document(s);
  3. The entity(ies) that prepared the document(s);
  4. The date the document(s) was prepared, and subsequent updates; and
  5. Where each document can be accessed<sup>1</sup> (website address or attached).

**Table 8-1. Storm Water Resource Plan Checklist and Self-Certification**

Storm Water Resource Plan Checklist and Self-Certification		
Note: Mandatory required elements per California Water Code are shaded		
Check if "Yes"	Plan Element	Water Code Section
Watershed Identification ( <i>Guidelines Section VI.A</i> )		
Check if "Yes"	Plan Element	Water Code Section
<input checked="" type="checkbox"/>	Plan identifies watershed and subwatershed(s) for storm water resource planning.	10565(c) 10562(b)(1) 10565(c)
<u>References:</u> <ul style="list-style-type: none"> <li>Sections 2.1 and 2.2</li> </ul>		
<input type="checkbox"/>	Plan is developed on a watershed basis, using boundaries as delineated by U.S. Geological Survey (USGS), CalWater, USGS Hydrologic Unit designations, or an applicable integrated regional water management group, and includes a description and boundary map of each watershed and sub-watershed applicable to the Plan.	
<u>References:</u>		

<sup>1</sup> All documents referenced must include a website address. If a document is not accessible to the public electronically, the document must be attached in the form of an electronic file (e.g. pdf or Word 2013) on a compact disk or other electronic transmittal tool.

Section Eight: SWRP Checklist and Self-Certification  
Kern County Storm Water Resource Plan

<b>Watershed Identification (Guidelines Section VI.A)</b>		
Check if "Yes"	Plan Element	Water Code Section
<input type="checkbox"/>	Plan includes an explanation of why the watershed(s) and sub-watershed(s) are appropriate for storm water management with a multiple-benefit watershed approach;	
<u>References:</u>		
<input type="checkbox"/>	Plan describes the internal boundaries within the watershed (boundaries of municipalities; service areas of individual water, wastewater, and land use agencies, including those not involved in the Plan; groundwater basin boundaries, etc.; preferably provided in a geographic information system shape file);	
<u>References:</u>		
<input type="checkbox"/>	Plan describes the water quality priorities within the watershed based on, at a minimum, applicable TMDLs and consideration of water body-pollutant combinations listed on the State's Clean Water Act Section 303(d) list of water quality limited segments (a.k.a impaired waters list);	
<u>References:</u>		
<input type="checkbox"/>	Plan describes the general quality and identification of surface and ground water resources within the watershed (preferably provided in a geographic information system shape file);	
<u>References:</u>		
<input type="checkbox"/>	Plan describes the local entity or entities that provide potable water supplies and the estimated volume of potable water provided by the water suppliers;	
<u>References:</u>		
<input type="checkbox"/>	Plan includes map(s) showing location of native habitats, creeks, lakes, rivers, parks, and other natural or open space within the sub-watershed boundaries; and	
<u>References:</u>		
<input type="checkbox"/>	Plan identifies (quantitative, if possible) the natural watershed processes that occur within the sub- watershed and a description of how those natural watershed processes have been disrupted within the sub-watershed (e.g., high levels of imperviousness convert the watershed processes of infiltration and interflow to surface runoff increasing runoff volumes; development commonly covers natural surfaces and often introduces non-native vegetation, preventing the natural supply of sediment from reaching receiving waters).	
<u>References:</u>		



Section Eight: SWRP Checklist and Self-Certification  
Kern County Storm Water Resource Plan

<b>Water Quality Compliance (Guidelines Section V)</b>		
Check if "Yes"	Plan Element	Water Code Section
<input checked="" type="checkbox"/>	Plan identifies activities that generate or contribute to the pollution of storm water or dry weather runoff, or that impair the effective beneficial use of storm water or dry weather runoff.	10562(d)(7)
References: <ul style="list-style-type: none"> <li>• Section 2.7</li> </ul>		
<input checked="" type="checkbox"/>	Plan describes how it is consistent with and assists in, compliance with total maximum daily load implementation plans and applicable national pollutant discharge elimination system permits.	10562(b)(5)
References: <ul style="list-style-type: none"> <li>• Section 3.1</li> </ul>		
<input checked="" type="checkbox"/>	Plan identifies applicable permits and describes how it meets all applicable waste discharge permit requirements.	10562(b)(6)
References: <ul style="list-style-type: none"> <li>• Sections 3.1, 3.3</li> </ul>		

<b>Organization, Coordination, Collaboration (Guidelines Section VI.B)</b>		
Check if "Yes"	Plan Element	Water Code Section
<input checked="" type="checkbox"/>	Local agencies and nongovernmental organizations were consulted in Plan development.	10565(a)
References: <ul style="list-style-type: none"> <li>• Sections 4.2, 4.3</li> </ul>		
<input checked="" type="checkbox"/>	Community participation was provided for in Plan development.	10562(b)(4)
References: <ul style="list-style-type: none"> <li>• Sections 4.5</li> </ul>		
<input type="checkbox"/>	Plan includes description of the existing integrated regional water management group(s) implementing an integrated regional water management plan.	
References:		
<input type="checkbox"/>	Plan includes identification of and coordination with agencies and organizations (including, but not limited to public agencies, nonprofit organizations, and privately owned water utilities) that need to participate and implement their own authorities and mandates in order to address the storm water and dry weather runoff management objectives of the Plan for the targeted	
References:		
<input type="checkbox"/>	Plan includes identification of nonprofit organizations working on storm water and dry weather resource planning or management in the watershed.	
References:		

Section Eight: SWRP Checklist and Self-Certification  
Kern County Storm Water Resource Plan

<b>Organization, Coordination, Collaboration (Guidelines Section VI.B)</b>		
Check if "Yes"	Plan Element	Water Code Section
<input type="checkbox"/>	Plan includes identification and discussion of public engagement efforts and community participation in Plan development.	
<u>References:</u>		
<input type="checkbox"/>	Plan includes identification of required decisions that must be made by local, state or federal regulatory agencies for Plan implementation and coordinated watershed-based or regional monitoring and visualization	
<u>References:</u>		
<input type="checkbox"/>	Plan describes planning and coordination of existing local governmental agencies, including where necessary new or altered governance structures to support collaboration among two or more lead local agencies responsible for plan implementation.	
<u>References:</u>		
<input type="checkbox"/>	Plan describes the relationship of the Plan to other existing planning documents, ordinances, and programs established by local agencies.	
<u>References:</u>		
<input type="checkbox"/>	(If applicable) Plan explains why individual agency participation in various isolated efforts is appropriate.	
<u>References:</u>		

<b>Quantitative Methods (Guidelines Section VI.C)</b>		
Check if "Yes"	Plan Element	Water Code Section
<input type="checkbox"/>	<b>For all analyses:</b> Plan includes an integrated metrics-based analysis to demonstrate that the Plan's proposed storm water and dry weather capture projects and programs will satisfy the Plan's identified water management objectives and multiple benefits.	
<u>References:</u>		
<input type="checkbox"/>	<b>For water quality project analysis (section VI.C.2.a):</b> Plan includes an analysis of how each project and program complies with or is consistent with an applicable NPDES permit. The analysis should simulate the proposed watershed-based outcomes using modeling, calculations, pollutant mass balances, water volume balances, and/or other methods of analysis. Describes how each project or program will contribute to the preservation, restoration, or enhancement of watershed processes (as described in Guidelines section VI.C.2.a)	
<u>References:</u>		

Section Eight: SWRP Checklist and Self-Certification  
Kern County Storm Water Resource Plan

<b>Quantitative Methods (Guidelines Section VI.C)</b>		
Check if "Yes"	Plan Element	Water Code Section
<input type="checkbox"/>	<b>For storm water capture and use project analysis (section VI.C.2.b):</b> Plan includes an analysis of how collectively the projects and programs in the watershed will capture and use the proposed amount of storm water and dry weather runoff.	
<u>References:</u>		
<input type="checkbox"/>	<b>For water supply and flood management project analysis (section VI.C.2.c):</b> Plan includes an analysis of how each project and program will maximize and/or augment water supply.	
<u>References:</u>		
<input type="checkbox"/>	<b>For environmental and community benefit analysis (section VI.C.2.d):</b> Plan includes a narrative of how each project and program will benefit the environment and/or community, with some type of quantitative measurement.	
<u>References:</u>		
<input type="checkbox"/>	<b>Data management (section VI.C.3):</b> Plan describes data collection and management, including: a) mechanisms by which data will be managed and stored; b) how data will be accessed by stakeholders and the public; c) how existing water quality and water quality monitoring will be assessed; d) frequency at which data will be updated; and e) how data gaps will be identified.	
<u>References:</u>		

<b>Identification and Prioritization of Projects (Guidelines Section VI.D)</b>		
Check if "Yes"	Plan Element	Water Code Section
<input checked="" type="checkbox"/>	Plan identifies opportunities to augment local water supply through groundwater recharge or storage for beneficial use of storm water and dry weather runoff.	10562(d)(1)
<u>References:</u>		
<ul style="list-style-type: none"> <li>• <b>Appendix A - Project Submittal Forms, Water Supply Benefits, Page 9 of 13, on each of the 12 proposed projects</b></li> </ul>		
<input checked="" type="checkbox"/>	Plan identifies opportunities for source control for both pollution and dry weather runoff volume, onsite and local infiltration, and use of storm water and dry weather runoff.	10562(d)(2)
<u>References:</u>		
<ul style="list-style-type: none"> <li>• <b>Appendix A - Project Submittal Forms, Water Quality Benefits, Page 8 of 13, on each of the 12 proposed projects</b></li> </ul>		
<input checked="" type="checkbox"/>	Plan identifies projects that reestablish natural water drainage treatment and infiltration systems, or mimic natural system functions to the maximum extent feasible.	10562(d)(3)
<u>References:</u>		
<ul style="list-style-type: none"> <li>• <b>Appendix A - Project Submittal Forms, Flood Management Benefits, Page 10 of 13, on each of the 12 proposed projects</b></li> </ul>		

Section Eight: SWRP Checklist and Self-Certification  
Kern County Storm Water Resource Plan

<b>Identification and Prioritization of Projects (Guidelines Section VI.D)</b>		
Check if "Yes"	Plan Element	Water Code Section
<input checked="" type="checkbox"/>	Plan identifies opportunities to develop, restore, or enhance habitat and open space through storm water and dry weather runoff management, including wetlands, riverside habitats, parkways, and parks.	10562(d)(4)
<u>References:</u> <ul style="list-style-type: none"> <li>• <b>Appendix A - Project Submittal Forms, Environmental and Habitat Enhancement Benefits, Page 11 of 13, on each of the 12 proposed projects</b></li> </ul>		
<input checked="" type="checkbox"/>	Plan identifies opportunities to use existing publicly owned lands and easements, including, but not limited to, parks, public open space, community gardens, farm and agricultural preserves, school sites, and government office buildings and complexes, to capture, clean, store, and use storm water and dry weather runoff either onsite or offsite.	10562(d)(5), 10562(b)(8)
<u>References:</u> <ul style="list-style-type: none"> <li>• <b>Appendix A - Project Submittal Forms, Environmental and Habitat Enhancement Benefits, Page 12 of 13, on each of the 12 proposed projects</b></li> </ul>		
<input checked="" type="checkbox"/>	For new development and redevelopments (if applicable): Plan identifies design criteria and best management practices to prevent storm water and dry weather runoff pollution and increase effective storm water and dry weather runoff management for new and upgraded infrastructure and residential, commercial, industrial, and public development.	10562(d)(6)
<u>References:</u> <ul style="list-style-type: none"> <li>• <b>Appendix A - Project Submittal Forms, Water Quality Benefits, Page 8 of 13, on each of the 12 proposed projects</b></li> </ul>		
<input checked="" type="checkbox"/>	Plan uses appropriate quantitative methods for prioritization of projects. (This should be accomplished by using a metrics-based and integrated evaluation and analysis of multiple benefits to maximize water supply, water quality, flood management, environmental, and other community benefits within the watershed.)	10562(b)(2)
<u>References:</u> <ul style="list-style-type: none"> <li>• <b>Section 5.4</b></li> </ul>		
<input type="checkbox"/>	<i>Overall:</i> Plan prioritizes projects and programs using a metric-driven approach and a geospatial analysis of multiple benefits to maximize water supply, water quality, flood management, environmental, and community benefits within the watershed.	
<u>References:</u>		
<input type="checkbox"/>	<i>Multiple benefits:</i> Each project in accordance with the Plan contributes to at least two or more <b>Main Benefits</b> and the maximum number of <b>Additional Benefits</b> as listed in Table 4 of the Guidelines. (Benefits are not counted twice if they apply to more than one category.)	
<u>References:</u>		

Section Eight: SWRP Checklist and Self-Certification  
Kern County Storm Water Resource Plan

Implementation Strategy and Schedule ( <i>Guidelines Section VI.E</i> )		
Check if "Yes"	Plan Element	Water Code Section
<input type="checkbox"/>	Plan identifies resources for Plan implementation, including: 1) projection of additional funding needs and sources for administration and implementation needs; and 2) schedule for arranging and securing Plan implementation financing.	
<u>References:</u>		
<input checked="" type="checkbox"/>	Plan projects and programs are identified to ensure the effective implementation of the storm water resource plan pursuant to this part and achieve multiple benefits.	10562(d)(8)
<u>References:</u>		
<ul style="list-style-type: none"> <li>• Sections 5.4, 5.5, and Table 5.2; Sections 6.1, 6.2, and Appendix C</li> </ul>		
<input checked="" type="checkbox"/>	The Plan identifies the development of appropriate decision support tools and the data necessary to use the decision support tools.	10562(d)(8)
<u>References:</u>		
<ul style="list-style-type: none"> <li>• Sections 5.4, 5.5, and Table 5.2, and Appendix C</li> </ul>		
<input type="checkbox"/>	Plan describes implementation strategy, including: <ul style="list-style-type: none"> <li>a) Timeline for submitting Plan into existing plans, as applicable;</li> <li>b) Specific actions by which Plan will be implemented;</li> <li>c) All entities responsible for project implementation;</li> <li>d) Description of community participation strategy;</li> <li>e) Procedures to track status of each project;</li> <li>f) Timelines for all active or planned projects;</li> <li>g) Procedures for ongoing review, updates, and adaptive management of the Plan; and</li> <li>h) A strategy and timeline for obtaining necessary federal, state, and local permits.</li> </ul>	
<u>References:</u>		
<input checked="" type="checkbox"/>	Applicable IRWM Plan: The Plan will be submitted, upon development, to the applicable integrated regional water management (IRWM) group for incorporation into the IRWM plan.	10562(b)(7)
<u>References:</u>		
<ul style="list-style-type: none"> <li>• Sections 5.1, 5.2, and 6.3</li> </ul>		
<input type="checkbox"/>	Plan describes how implementation performance measures will be tracked.	
<u>References:</u>		

Section Eight: SWRP Checklist and Self-Certification  
Kern County Storm Water Resource Plan

<b>Education, Outreach, Public Participation (Guidelines Section VI.F)</b>		
Check if "Yes"	Plan Element	Water Code Section
<input checked="" type="checkbox"/>	Outreach and Scoping: Community participation is provided for in Plan implementation.	10562(b)(4)
References: <ul style="list-style-type: none"> <li>• Sections 7.1 and 7.2</li> </ul>		
<input type="checkbox"/>	Plan describes public education and public participation opportunities to engage the public when considering major technical and policy issues related to the development and implementation.	
References:		
<input type="checkbox"/>	Plan describes mechanisms, processes, and milestones that have been or will be used to facilitate public participation and communication during development and implementation of the Plan.	
References:		
<input type="checkbox"/>	Plan describes mechanisms to engage communities in project design and implementation.	
References:		
<input type="checkbox"/>	Plan identifies specific audiences including local ratepayers, developers, locally regulated commercial and industrial stakeholders, nonprofit organizations, and the general public.	
References:		
<input type="checkbox"/>	Plan describes strategies to engage disadvantaged and climate vulnerable communities within the Plan boundaries and ongoing tracking of their involvement in the planning process.	
References:		
<input type="checkbox"/>	Plan describes efforts to identify and address environmental injustice needs and issues within the watershed.	
References:		
<input type="checkbox"/>	Plan includes a schedule for initial public engagement and education.	
References:		

## 8.2 Declaration and Signature

**I declare under penalty of perjury that all information provided is true and correct to the best of my knowledge and belief.**

\_\_\_\_\_  
Signature Title Date

\_\_\_\_\_  
Signature Title Date

## 9 References

- California Department of Water Resources. (2016). *IRWM Boundary Map*. Retrieved from <http://www.water.ca.gov/waterplan/gis/index.cfm>.
- California Department of Water Resources. (Last modified on Oct. 18, 2016 by DWR). *Groundwater Basins Map*. Bulletin 118.  
Retrieved from [http://water.ca.gov/groundwater/sgm/basin\\_boundaries.cfm](http://water.ca.gov/groundwater/sgm/basin_boundaries.cfm).
- California Department of Water Resources. (Last modified on June 20, 2016 by DWR). *Kern County Cities and Communities, and Disadvantaged Cities and Communities Maps*. Retrieved from <https://gis.water.ca.gov/app/boundaries/>.
- California Regional Water Quality Control Board, Central Valley Region. (Revised January 2004, amended March 2014). *Water Quality Control Plan for the Tulare Lake Basin, Second Edition*.
- Kennedy/Jenks Consultants. (November 2011). *Tulare Lake Basin Portion of Kern County Integrated Regional Water Management Plan – Final Update*. Prepared for Kern County Water Agency on behalf of Kern IRWMP Regional Water Management Group.
- GEI Consultants. (June 2014). *Poso Creek Integrated Regional Water Management Plan – 2014 Update*. Prepared on behalf of Poso Creek IRWMP Regional Water Management Group
- GEI Consultants. (Updated December 2016). *Figure: Flood Water Capture and Distribution Infrastructure*. Originally included in Poso Creek Integrated Regional Water Management Plan – 2014 Update. Prepared on behalf of Poso Creek IRWMP Regional Water Management Group
- Iger, Rick. (June 27, 2012). Presentation on Kern County Water Supply – A History of Water in Kern County. *Southern San Joaquin Valley of Kern County Recharge Sites*. Figure originally by County of Kern.
- Poso Creek IRWMP Regional Water Management Group. (September 2013). Poso Creek IRWM Public Involvement Plan (PIP), *Supplement to the 2007 Poso Creek Integrated Regional Water Management Plan*.
- Provost & Pritchard Consulting Group. (August 2014). *Disadvantaged Community Water Study for the Tulare Lake Basin*. Prepared on behalf of County of Tulare.
- Provost & Pritchard Consulting Group. (February 2015). *Groundwater Quality Assessment Report*. Prepared on behalf of Kern River Watershed Coalition Authority.
- State Water Resources Control Board. (December 15, 2015). *Proposition 1 Storm Water Grant Program Guidelines*.



State Water Resources Control Board. (December 15, 2015). *Storm Water Resource Plan Guidelines*.

State Water Resources Control Board. (2010). *303(d) List of Impaired Water Bodies within Kern County*. 2010 303(d) Integrated Report (Clean Water Section 303(d) List/305(b) Report). Retrieved from [http://www.waterboards.ca.gov/water\\_issues/programs/tmdl/integrated2010.shtml](http://www.waterboards.ca.gov/water_issues/programs/tmdl/integrated2010.shtml)

U.S. Department of Agriculture (USDA) Natural Resources Conservation Services. (2016). *Watershed Boundary Dataset*. Retrieved from [http://egis.fire.ca.gov/watershed\\_mapper/PDF/calw221\\_with\\_Fish\\_ESU\\_County.htm](http://egis.fire.ca.gov/watershed_mapper/PDF/calw221_with_Fish_ESU_County.htm).

U.S. Geological Survey (USGS). (2016). Water Data Reports and Geographic Information Systems (GIS) data. Retrieved from <http://water.usgs.gov/maps.html>

# Figures

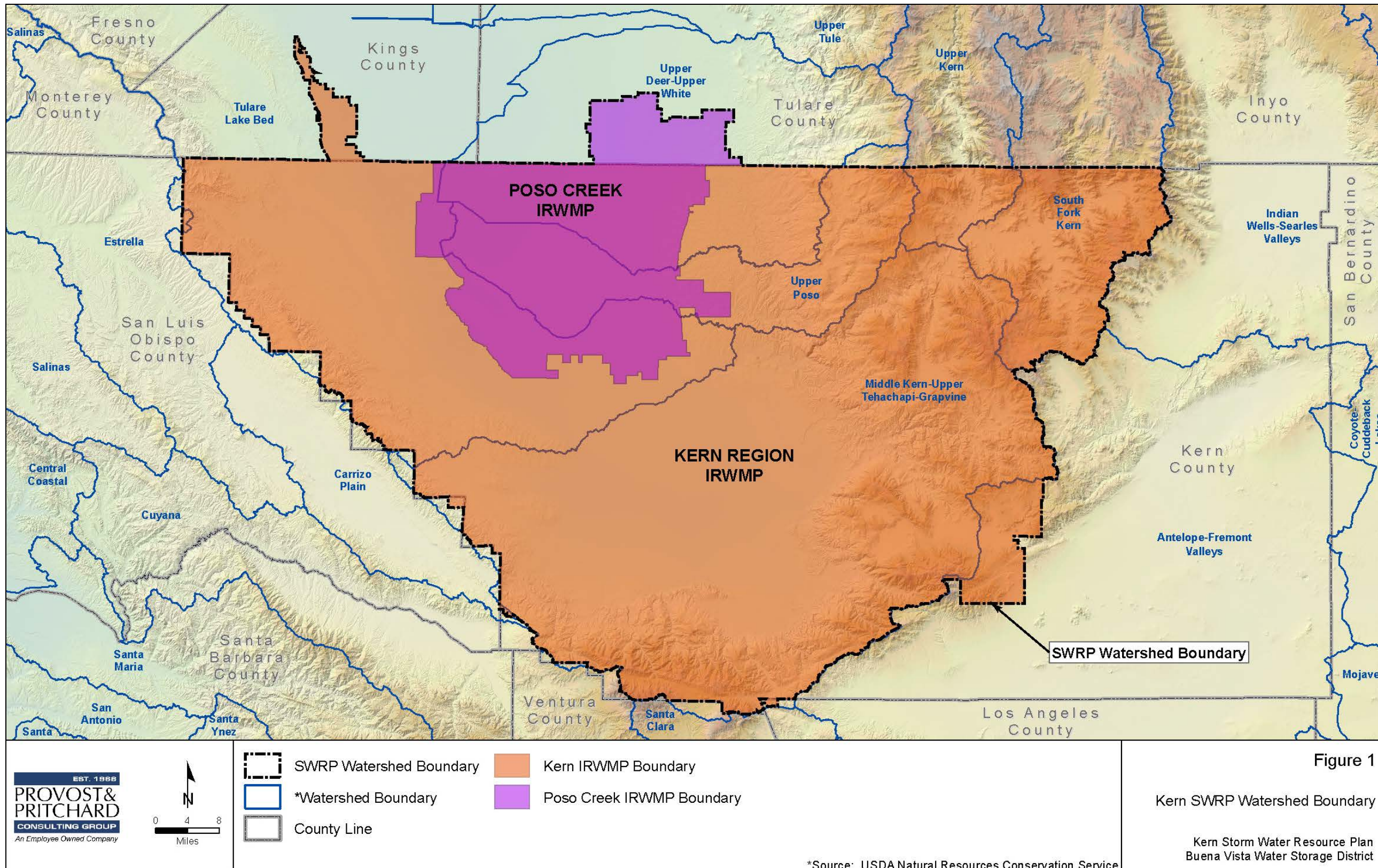

Figure 1. Kern SWRP Watershed Boundary Map

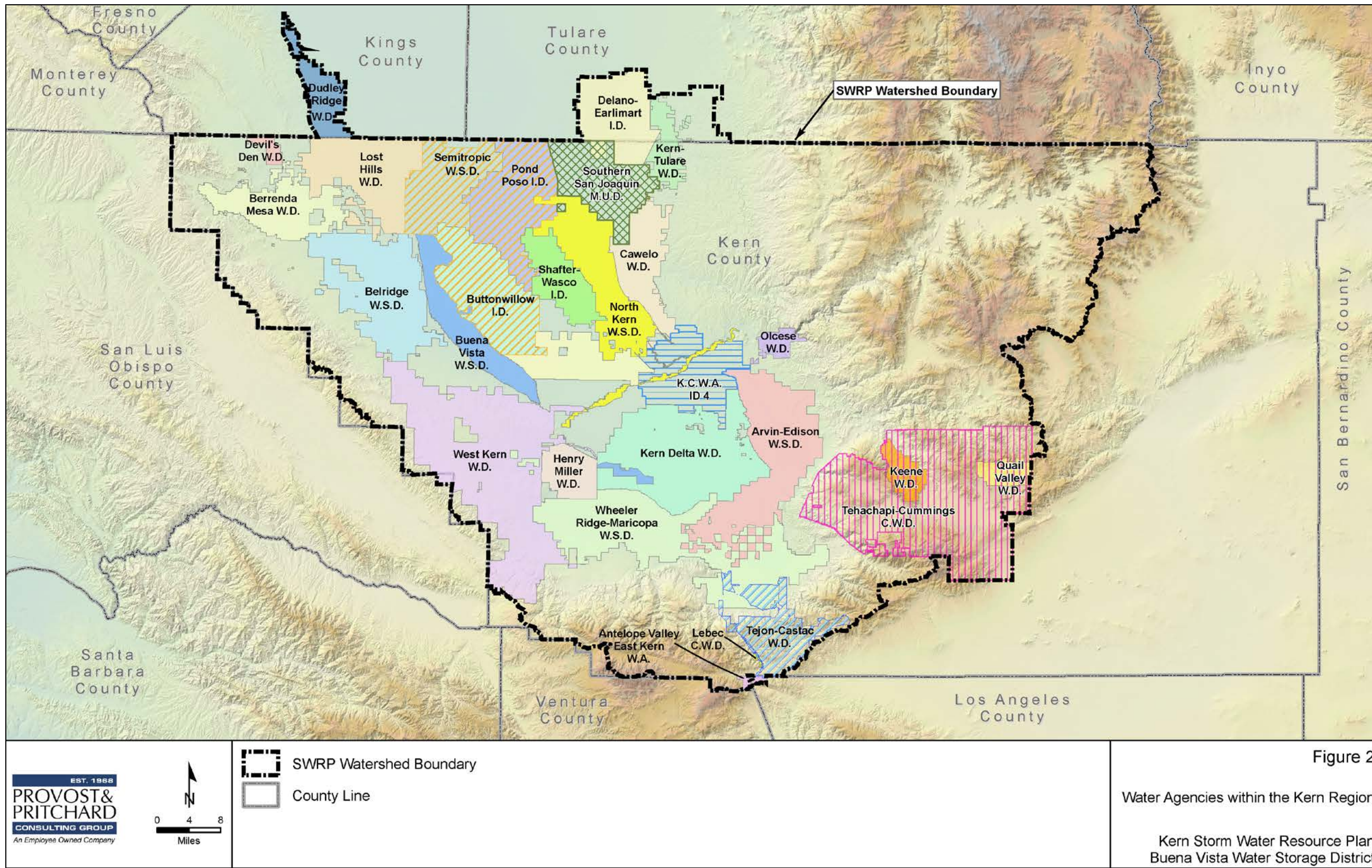

Figure 2. Water Agencies within the Kern Region

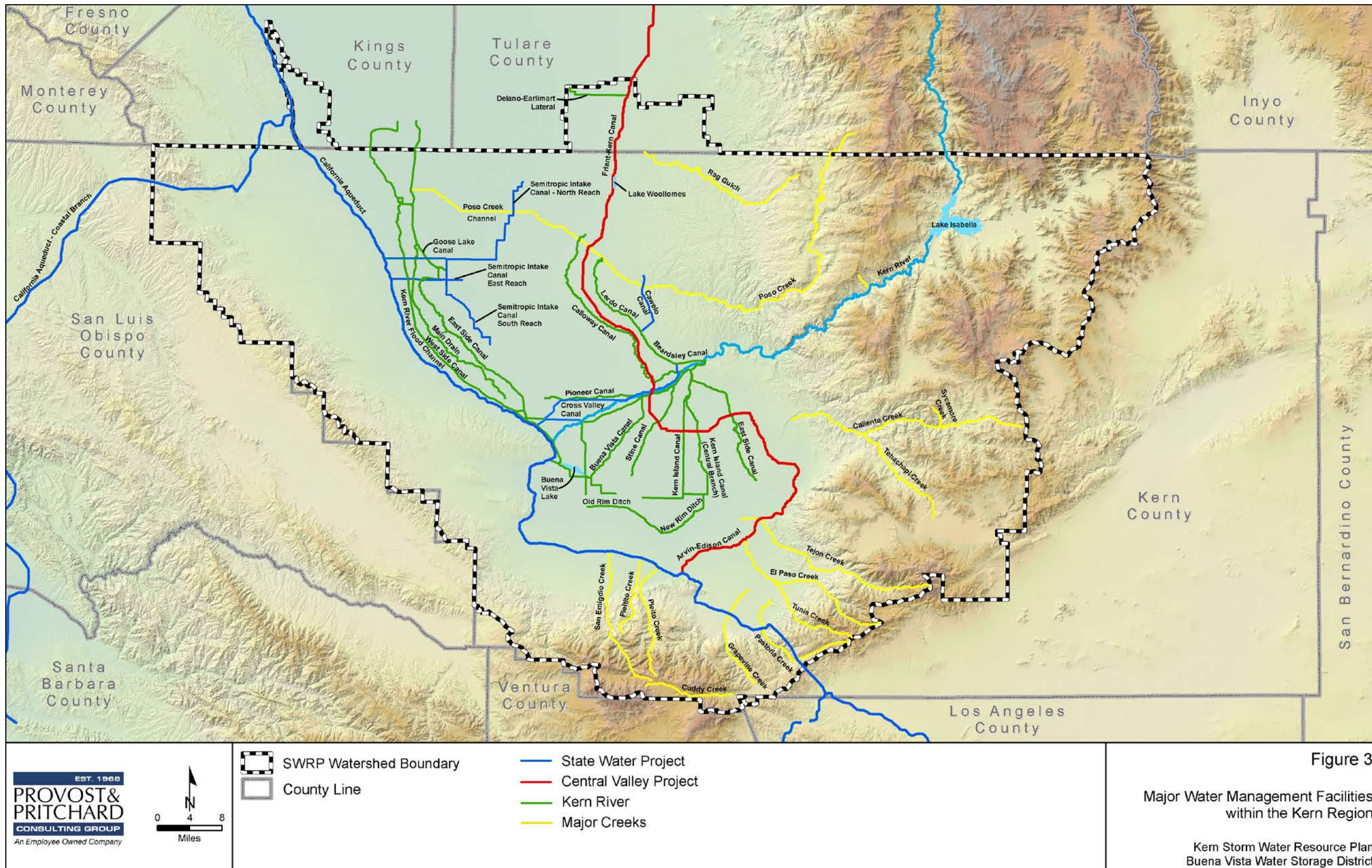

Figure 3. Major Water Management Facilities within the Kern Region

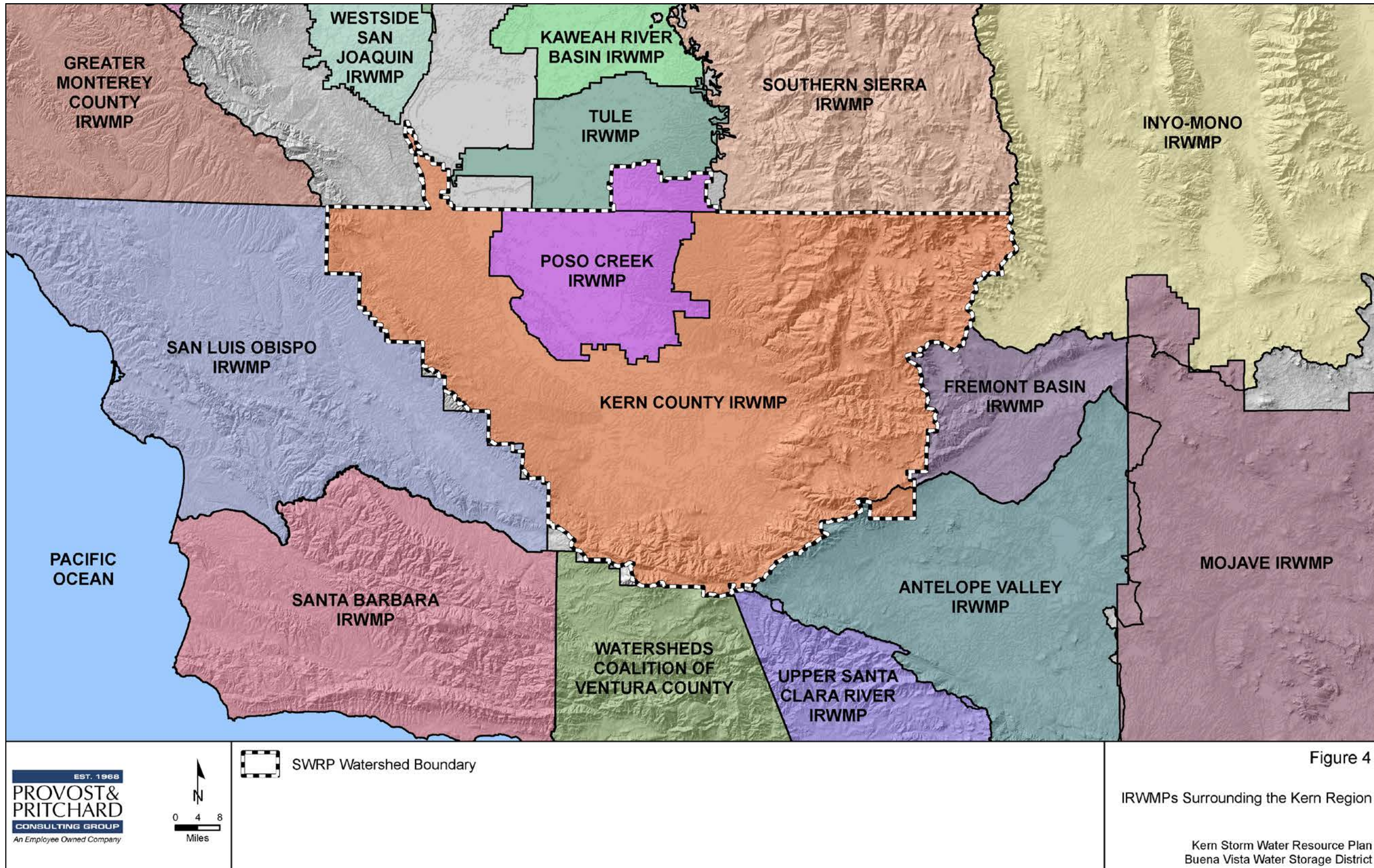

Figure 4. IRWMPs Surrounding the Kern Region

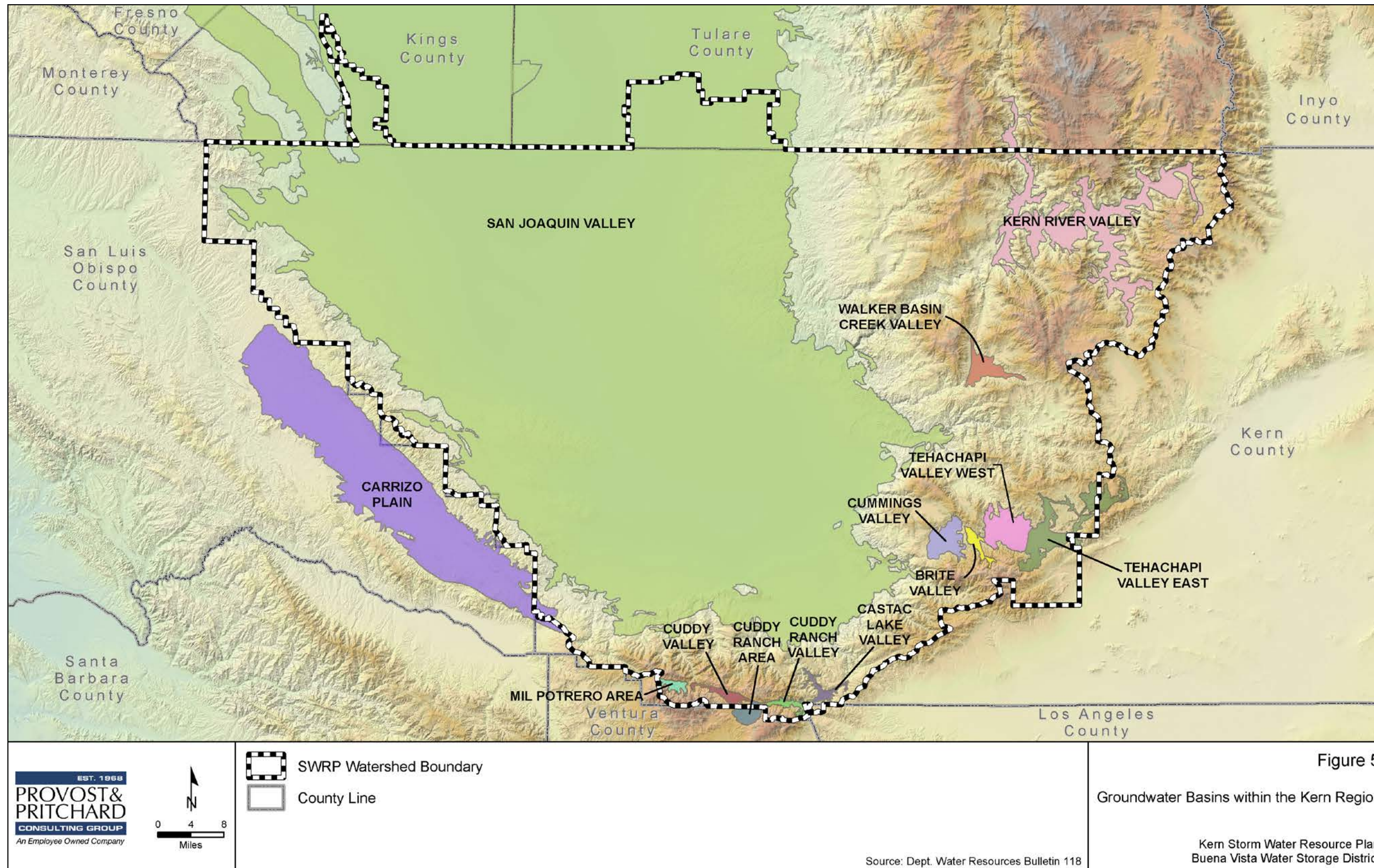

Figure 5. Groundwater Basins within the Kern Region

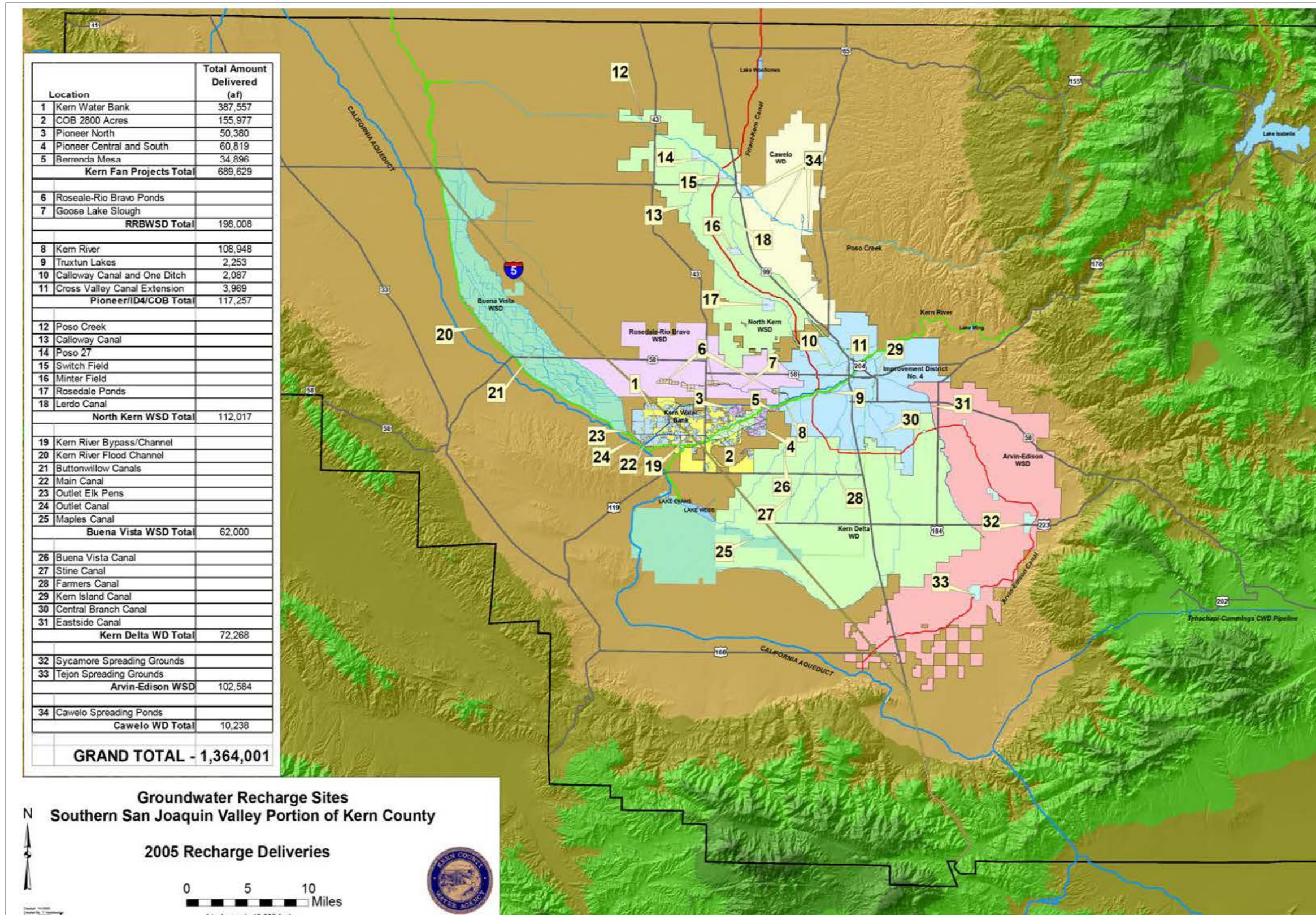

Figure 6. Groundwater Recharge Areas of the Kern Region



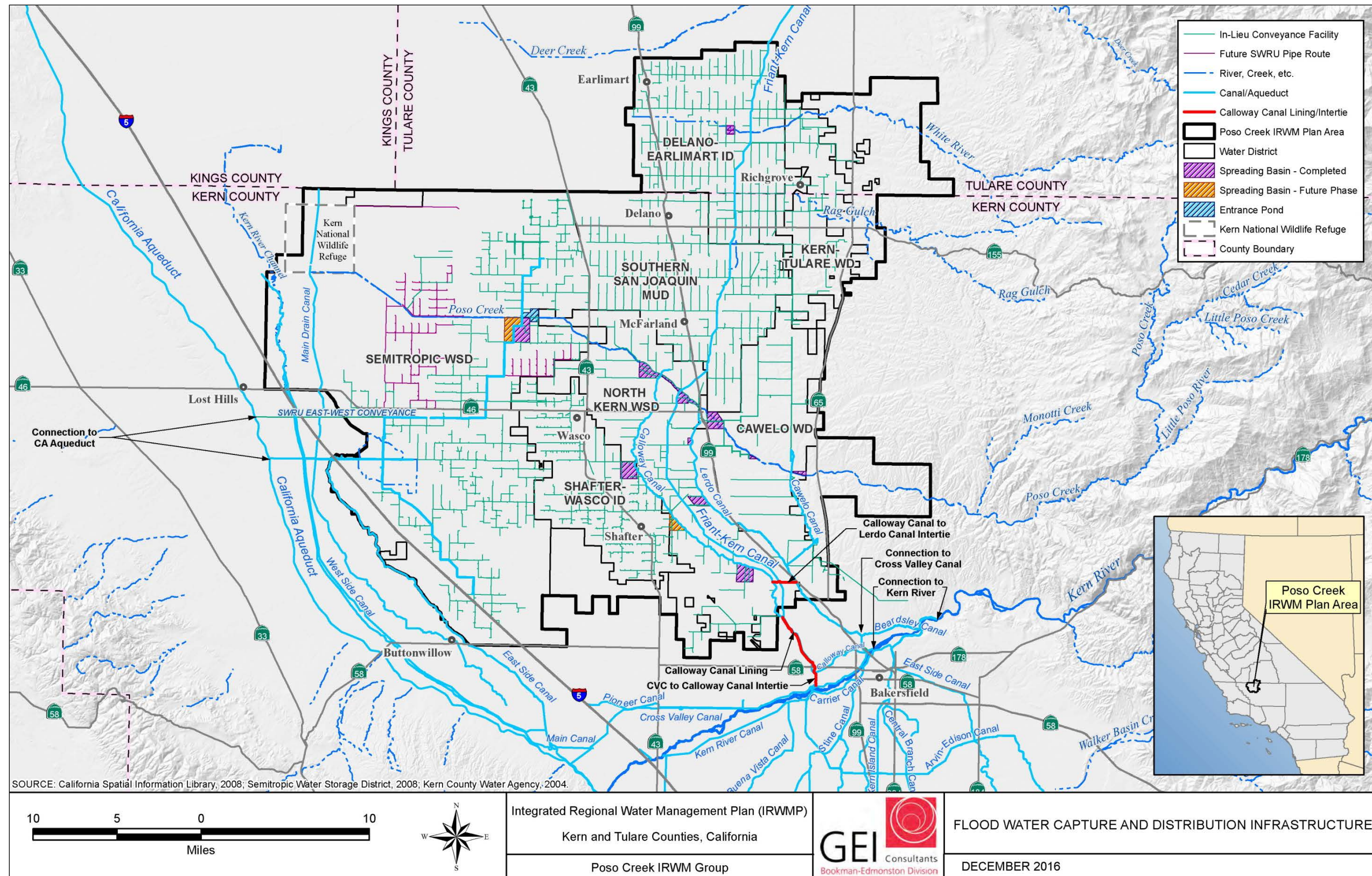
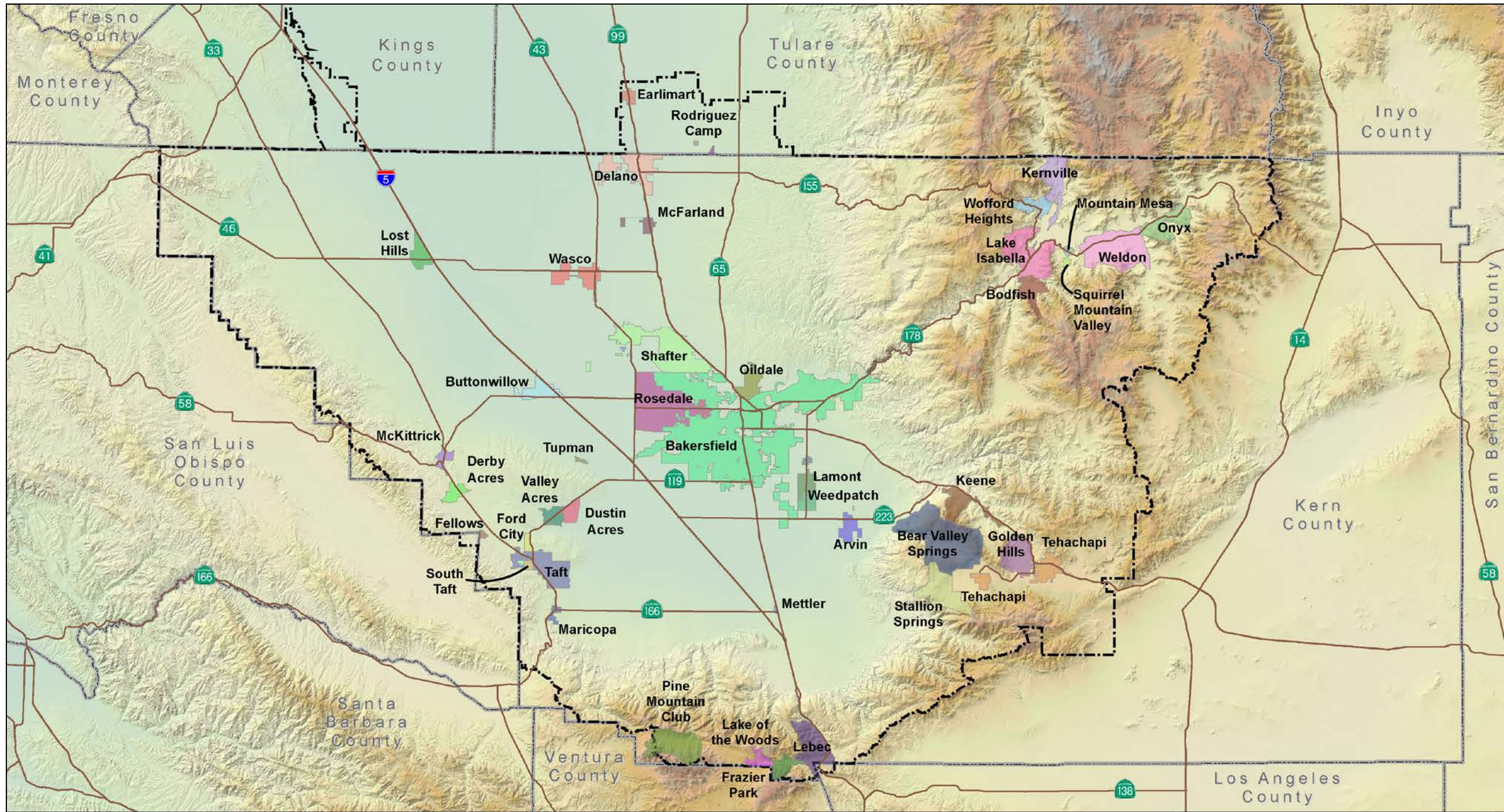

Figure 7. Flood Water Capture and Distribution Infrastructure for Poso Creek IRWM Group



		<ul style="list-style-type: none"> <li> SWRP Watershed Boundary</li> <li> County Line</li> </ul>	<p><b>Figure 8</b></p>
<p>Cities and Communities within the Kern Region</p>			<p>Kern Storm Water Resource Plan Buena Vista Water Storage District</p>
<p>Source: Tulare Lake Basin DAC Water Study and CA DWR DAC data, US Census</p>			

Figure 8. Cities and Communities within the Kern Region

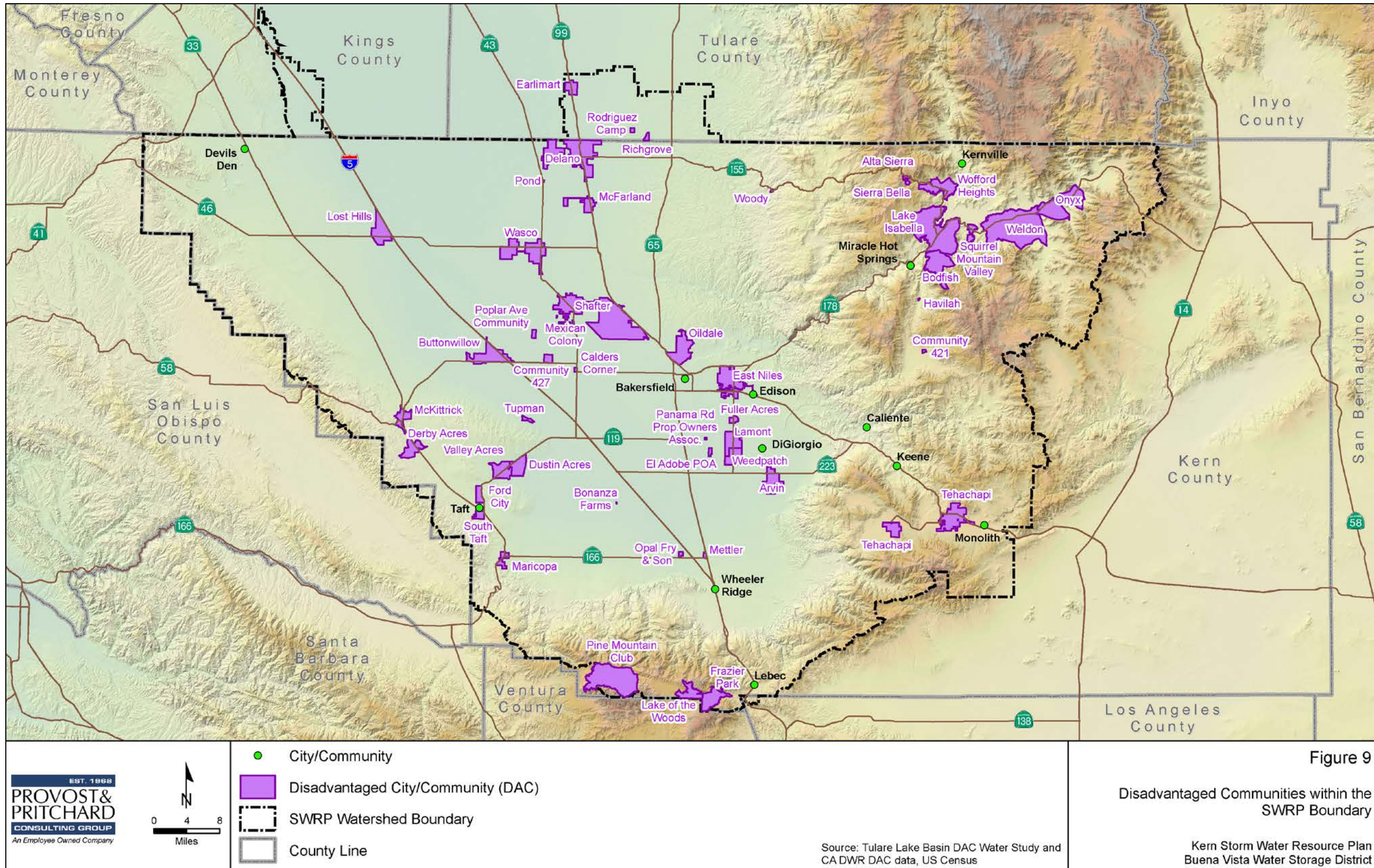

Figure 9. Disadvantaged Communities within the Kern Region

# Appendix A: Project Submittal Form Template

# Kern Storm Water Resource Plan

## Project Submittal Form

This form is to be electronically filled out and e-mailed to [LMarino@ppeng.com](mailto:LMarino@ppeng.com) by June 24, 2016.

Reference: [Storm Water Resource Plan Guidelines](#), December 15, 2015  
State Water Resources Control Board

### Part 1. Lead Implementing Agency/Organizational Information

Please provide the following information regarding the project sponsor and proposed project.

**Implementing Agency / Organization / Individual:**

**Agency / Organization / Individual Address:**

**Possible Partnering Agencies:**

**Name:**

**Title:**

**Telephone:**

**Fax:**

**Email:**

**Website:**

**Project Name:**

Either the latitude/longitude or a location description is required. To determine the latitude/longitude, use the closest address or intersection. If the project is linear, use the furthest upstream latitude/longitude.

**Project Latitude:**  **Project Longitude:**

<b>Location Description:</b>	
------------------------------	--

**Project Cooperating Agency(ies)/Organization(s)/Individual(s):**

•
•
•
•

**Project Status (e.g., new, ongoing, expansion, new phase):**

**Has the Project been submitted to IRWM Plan:**

Kern IRWMP                       Poso Creek IRWMP                       Not Submitted

**Does the project address any known environmental justice issues?**

Yes                                       No                                       Not Sure

**Is the project located within or adjacent to a disadvantaged community (DAC)? Refer to this [website](#).**

Within                                       Adjacent                                       No                                       Not Sure

**Does the project include DAC participation?**

Yes                                       No                                       Not Sure

If yes, please identify the contact person, group, or organization and describe the DAC's participation:

What is the DAC's estimated population:

Does the Implementing Agency own the land where the project is located? If no, describe ability to purchase land or if eminent domain is required:

Yes                                       No

## Part 2. Project Need

It is important to understand the need(s) or issue(s) that the proposed project will address and the benefits that it will provide. Information provided in this section defines the need(s) or issue(s) that the proposed project will address and will help to catalog existing need(s) or issue(s) in the planning area of the Kern Storm Water Resource Plan.

Please provide a 1-2 paragraph description of the need(s) or problem(s) that the proposed project will address. Discuss the benefits to water quality, water supply, flood management, environmental, and community benefits that the proposed project will bring. Discuss critical impacts or worsening conditions that will occur if the proposed project is not implemented.

### Project Need (Narrative)

### Part 3. Project Description

A general description of the proposed project is needed. This section will provide information associated with the project concept and general project information. Much of the requested information may not be available for projects that are in the conceptual stages of development. An essential element of the Kern Storm Water Resource Plan consists of proposed projects. We appreciate and need your ideas.

Please provide a one or two paragraph description of the project including the general project concept, what will be constructed/implemented, how the constructed project will function, what technologies or methods will be used, as appropriate. For water quality projects, include a description of impacts to existing Total Maximum Daily Loads, NPDES permits, and/or waste discharge requirements.

#### Project Description (Narrative)

--

If applicable, list surface water bodies and groundwater basins associated with the proposed project:

•
•
•
•

Please identify up to three available documents which contain information specific to the proposed project. Include conceptual plans, permits, drawings, and technical documents:

•
•
•



Please identify federal, state, or local permits, which pertain to the proposed project and would need to be obtained or, if existing, would need to be amended:

•
•
•

Please identify any existing projects or facilities, including existing water conveyance infrastructure, which would be affected, modified, or superseded as a result of implementing the proposed project:

•
•
•

Is the proposed project an element or phase of a regional or larger program?:	<input type="checkbox"/> Yes	<input type="checkbox"/> No
If yes, please identify the program:		
Design life of the project:		
Proposed Construction/Implementation Start Date:		
Proposed Construction/Implementation Completion Date:		
Ready for Construction Bid:	<input type="checkbox"/> Yes	<input type="checkbox"/> No <input type="checkbox"/> N/A

Item	Status (e.g., not initiated, in process, complete)	Date (mm/dd/yyyy)
Conceptual Plans		
Land Acquisition/ Easements		
Preliminary Plans		
CEQA/NEPA		
Permits		
Construction Drawings		

For projects ready for construction or implementation, including projects which do not include construction, briefly describe the project's readiness to proceed.

**Project Readiness (Narrative)**

Include any local or state board actions, code changes, or legislation needed in order to proceed with the project.

**Local or State Board Actions, Code Changes, or Legislation**

**Please describe the dominant existing land use type for the proposed project location.**

**Please describe the dominant existing land use type for areas upstream and downstream of the proposed project location**

Upstream:	
Downstream:	

## Part 4. Project Benefits

Please provide a one or two paragraph description of the benefit(s) that the project will address. Benefit Categories, shown below, are referenced from the [Storm Water Resource Plan Guidelines](#), Page 31, Table 4. Each project should address at least two or more Main Benefits and as many Additional Benefits as feasible. Information you provide will be used to evaluate the project for State grant funding.

Storm Water Management Benefits		
Benefit Category	Main Benefit	Additional Benefit
<b>Water Quality</b> (while contributing to compliance with applicable permit and/or TMDL requirements)	<ul style="list-style-type: none"> <li>Increased filtration and/or treatment of run-off</li> </ul>	<ul style="list-style-type: none"> <li>Non-point source pollution control</li> <li>Reestablished natural water drainage and treatment</li> </ul>
<b>Water Supply</b> (through groundwater management and/or run-off capture and use)	<ul style="list-style-type: none"> <li>Water supply reliability</li> <li>Conjunctive use</li> </ul>	<ul style="list-style-type: none"> <li>Water conservation</li> </ul>
<b>Flood Management</b>	<ul style="list-style-type: none"> <li>Decreased flood risk by reducing run-off rate and/or volume</li> </ul>	<ul style="list-style-type: none"> <li>Reduced sanitary sewer overflows</li> </ul>
<b>Environmental and Habitat Enhancement</b>	<ul style="list-style-type: none"> <li>Environmental and habitat protection and improvement, including;                             <ul style="list-style-type: none"> <li>wetland enhancement/creation;</li> <li>riparian enhancement; and/or</li> <li>instream flow improvement</li> </ul> </li> <li>Increased urban green space</li> </ul>	<ul style="list-style-type: none"> <li>Reduced energy use, greenhouse gas emissions, or provides a carbon sink</li> <li>Reestablishment of the natural hydrograph</li> <li>Water temperature improvements</li> </ul>
<b>Community Stewardship</b>	<ul style="list-style-type: none"> <li>Employment opportunities provided</li> <li>Public Education</li> </ul>	<ul style="list-style-type: none"> <li>Community involvement</li> <li>Enhance and/or create recreational and public use areas</li> </ul>

Source: Page 31, Table 4, Storm Water Resource Plan Guidelines, State Water Resources Control Board

Please provide the following **PROJECT BENEFIT** information for all applicable components of the proposed project. Benefit categories include:

- **Water Quality**
- **Water Supply**
- **Flood Management**
- **Environmental and Habitat Enhancement**
- **Community Stewardship**

If the project benefits a disadvantaged community (DAC) describe the specific benefits to that community. Estimate the percentage of the project benefits to the DAC.

Please supply all information relevant to the proposed project. The information you provide will be used to evaluate the project for State grant funding. **Attach additional sheets if necessary.**

## Water Quality Benefits

1. Describe how the proposed project will improve source control for both pollution and dry weather runoff volume, onsite and local infiltration, and use of storm water and dry weather runoff.
2. Describe design criteria and best management practices to prevent storm water and dry weather runoff pollution and increase effective storm water and dry weather runoff management for new and upgraded infrastructure and residential, commercial, industrial, and public development
3. Describe how the proposed project complies with or is consistent with an applicable NPDES permit. The analysis should simulate the proposed watershed-based outcomes using modeling, calculations, pollutant mass balances, water volume balances, and/or other methods of analysis. Describe how the proposed project will contribute to the preservation, restoration, or enhancement of watershed processes (as described in Guidelines section VI.C.2.a)
4. Describe the water quality monitoring and data acquisition that will be implemented in conjunction with the proposed project. Describe the a) mechanisms by which data will be managed and stored; b) how data will be accessed by stakeholders and the public; c) how existing water quality and water quality monitoring will be assessed; d) frequency at which data will be updated; and e) how data gaps will be identified.

### Water Quality Benefits (Narrative)

Pollutant TMDL reduction (Volume per day) and (mass /unit volume) of most probable number of bacteria or indicator organisms (mpn/mL):	
Increase in infiltration rate above existing condition:	
Non-point source pollution control:	
Does project affect an Existing NPDES Permit? If applicable, describe the need for a new NPDES Permit:	

## Water Supply Benefits

1. Describe how the proposed project captures and reuses storm water and dry weather runoff for groundwater recharge or storage for beneficial use.
2. Please provide detailed information to quantify how the proposed project will reduce existing potable water demand.
3. Describe the water supply monitoring and data acquisition that will be implemented in conjunction with the proposed project. Describe the a) mechanisms by which data will be managed and stored; b) how data will be accessed by stakeholders and the public; c) how existing water quality and water quality monitoring will be assessed; d) frequency at which data will be updated; and e) how data gaps will be identified

### Water Supply Benefits (Narrative)

--

### Enhanced Water Supply or Demand Reduction Benefit Information

<b>Source of Increased Supply or Demand Reduction</b>	
<input type="checkbox"/> Groundwater	<input type="checkbox"/> Groundwater treatment
<input type="checkbox"/> Recycled water	<input type="checkbox"/> Conservation/ water use efficiency
<input type="checkbox"/> Transfer	<input type="checkbox"/> Other (describe):
<input type="checkbox"/> Increased surface water storage	<input type="checkbox"/> Ocean desalination
Type of enhanced supply or demand reduction:	
Annual Yield of Supply (acre-feet):	
<b>Availability by Water-Year Type (acre-feet per year)</b>	
Average Year:	
Dry Year:	
Wet Year:	
<b>Availability by Season (check all that apply):</b>	
<input type="checkbox"/> Summer	<input type="checkbox"/> Fall
<input type="checkbox"/> Spring	<input type="checkbox"/> Winter
<b>Does the project have the potential to reduce dependence on the Sacramento San Joaquin Bay-Delta?</b>	
<input type="checkbox"/> Yes	<input type="checkbox"/> No
<input type="checkbox"/> Not Sure	

## Flood Management Benefits

1. Describe how the proposed project will reestablish natural water drainage treatment and infiltration systems, or mimic natural system functions to the maximum extent feasible.
2. Describe how the proposed project will reduce flood risk by reducing runoff rate and/or volume.
3. If applicable, describe how the proposed project will reduce the risk of sanitary sewer overflows.

### Flood Management Benefits (Narrative)

Description facilities protected:	
Maximum volume of temporary storage of storm water runoff (acre-feet):	
Maximum increased conveyance capacity (cubic feet/second):	
Estimated area benefiting from flood damage reduction (acres):	
Estimated level of flood protection resulting from project implementation (% annual probability of recurrence or 1-in-number of years recurrence):	
Estimated annual value of flood damage reduction provided by project (\$/year):	
Land required for project implementation (acres):	

### For projects that include detention and groundwater recharge, please complete the following:

How many acres of land drain into this detention basin? (acres):	
Detention Basin area (acres):	
Detention basin max. operational depth (ft.):	
% of basin covered by wetlands:	
Soil type:	
If other than infiltration, identify method (e.g., injection) and recharge (acre-feet/year):	
Estimated basin annual inflow (acre-feet/year):	
Estimated basin annual outflow (acre-feet/year):	

## Environmental and Habitat Enhancement Benefits

Describe how the proposed project identifies opportunities to develop, restore, or enhance habitat and open space through storm water and dry weather runoff management, including wetlands, riverside habitats, parkways, and parks. Provide some type of quantitative measurement, which will show how the project benefits the environment and enhances the natural habitat.

### Environmental and Habitat Enhancement Benefits (Narrative)

Non-treatment wetland area (acres):	
Treatment wetland area (acres):	
Riparian habitat area (acres):	
Non-developed open space area (acres):	
Total Project area (acres):	

## Community Stewardship Benefits

Describe how the project identifies opportunities to use existing publicly owned lands and easements, including, but not limited to parks, open space, community gardens, farm and agricultural preserves, school sites, and government office buildings and complexes, to capture, clean, store, and use storm water and dry weather runoff either onsite or offsite. Provide some type of quantitative measurement, which will show how the project benefits the community.

### Community Stewardship Benefits (Narrative)

--

**Multiple use/ recreation area (acres) – additionally, select the type of multiple use / recreation and associated acres by type:**

Single Sport Athletics:	
Multiple Sport Athletics Acres:	
Other Recreation Acres:	
Pedestrian Trail Acres:	
Equestrian Trail Acres:	
Other Passive Activity:	
Other Acres (describe):	
Description:	
<b>Total Project Area (acres):</b>	



## Part 5. Project Cost Estimate

Project cost information is needed to assist in comparing benefits and cost. Additionally, knowledge of the project type and cost will assist in identifying funding sources for potential projects.

Please indicate the estimated costs of project implementation and associated funding source(s). These costs should include land purchase/easement, planning/design/engineering, construction/ implementation, environmental compliance, administration, and contingency.

<p><b>Approximate Total Cost:</b> (If project costs are variable, please include lower and upper range estimates.)</p>	
<p><b>Funding Source:</b> (If multiple sources, list each source and the percent or amount funded by each)</p>	
<p><b>Maximum Funding Match from Implementing Agency:</b></p>	
<p><b>Funding Certainty &amp; Longevity:</b></p>	
<p><b>Operations &amp; Maintenance Cost:</b> (per year)</p>	
<p><b>Operations &amp; Maintenance Funding Source(s)</b> (i.e., annual budget, grant, etc. If multiple sources, list each source and the percent or amount funded by each.)</p>	
<p><b>Operations &amp; Maintenance Funding Certainty:</b> (i.e., already included in organization's budget, contingent upon grant, etc.)</p>	

# Appendix B: Project Submittal Forms

# Kern Storm Water Resource Plan

## Project Submittal Form

This form is to be electronically filled out and e-mailed to [LMarino@ppeng.com](mailto:LMarino@ppeng.com) by June 24, 2016.

Reference: [Storm Water Resource Plan Guidelines](#), December 15, 2015  
State Water Resources Control Board

### Part 1. Lead Implementing Agency/Organizational Information

Please provide the following information regarding the project sponsor and proposed project.

**Implementing Agency / Organization / Individual:**

Semitropic Water Storage District

**Agency / Organization / Individual Address:**

1101 Central Ave, Wasco, CA 93280

**Possible Partnering Agencies:**

**Name:**

**Title:**

Jason Gianquinto

**Telephone:**

661-758-5113

**Fax:**

661-758-3219

**Email:**

[mail@semitropic.com](mailto:mail@semitropic.com)

**Website:**

[www.semitropic.com](http://www.semitropic.com)

**Project Name:**

Schuster Spreading Grounds

Either the latitude/longitude or a location description is required. To determine the latitude/longitude, use the closest address or intersection. If the project is linear, use the furthest upstream latitude/longitude.

**Project Latitude:**  **Project Longitude:**

<b>Location Description:</b>	Northwest of the intersection of Shuster Road and Highway 43, about 5.8 miles southwest of Delano, within the west half of Section 24, Township 25 South, Range 24 East, MDB&M.
------------------------------	---

**Project Cooperating Agency(ies)/Organization(s)/Individual(s):**

- |   |
|---|
| <ul style="list-style-type: none"><li>• Neighboring Water Districts</li></ul> |
| <ul style="list-style-type: none"><li>• Other Interested Parties</li></ul>    |
|   |
|   |

**Project Status (e.g., new, ongoing, expansion, new phase):**

**Has the Project been submitted to IRWM Plan:**

Kern IRWMP       Poso Creek IRWMP       Not Submitted

**Does the project address any known environmental justice issues?**

Yes       No       Not Sure

**Is the project located within or adjacent to a disadvantaged community (DAC)? Refer to this [website](#).**

Within       Adjacent       No       Not Sure

**Does the project include DAC participation?**

Yes       No       Not Sure

If yes, please identify the contact person, group, or organization and describe the DAC's participation:

What is the DAC's estimated population?

Does the Implementing Agency own the land where the project is located? If no, describe ability to purchase land or if eminent domain is required:

Yes       No

## Part 2. Project Need

It is important to understand the need(s) or issue(s) that the proposed project will address and the benefits that it will provide. Information provided in this section defines the need(s) or issue(s) that the proposed project will address and will help to catalog existing need(s) or issue(s) in the planning area of the Kern Storm Water Resource Plan.

Please provide a 1-2 paragraph description of the need(s) or problem(s) that the proposed project will address. Discuss the benefits to water quality, water supply, flood management, environmental, and community benefits that the proposed project will bring. Discuss critical impacts or worsening conditions that will occur if the proposed project is not implemented.

### Project Need (Narrative)

The Schuster Spreading Grounds (the Project) is part of the District's portfolio of projects that would advance the District's conjunctive use objectives. The Project will allow the District to absorb and manage surface water supplies originating from the various sources of surface supplies or "flavors of water" available to the District through banking arrangements/ transfers/ or exchanges including State Water Project (SWP) from the CA Aqueduct, Central Valley Project (CVP) water from the Friant-Kern Canal, and Kern River water for direct use within the District. Additionally, the Project would provide recharge ponds for diversion, capture, and recharge of flood flows from the Poso Creek Flood Channel for ultimate recharge and storage of surplus water.

The primary purpose of the Project is to improve the sustainability of the local water supplies and conjunctively manage the surface and groundwater resource for the benefit of the area. The need results from a number of actions which have served to reduce the historical reliability of water supplies available to the region.

### Part 3. Project Description

A general description of the proposed project is needed. This section will provide information associated with the project concept and general project information. Much of the requested information may not be available for projects that are in the conceptual stages of development. An essential element of the Kern Storm Water Resource Plan consists of proposed projects. We appreciate and need your ideas.

Please provide a one or two paragraph description of the project including the general project concept, what will be constructed/implemented, how the constructed project will function, what technologies or methods will be used, as appropriate. For water quality projects, include a description of impacts to existing Total Maximum Daily Loads, NPDES permits, and/or waste discharge requirements.

**Project Description (Narrative)**

<p>The Project consists of the following facilities:</p> <p>Development of 70 gross acres into diked ponds;</p> <p>Modifications to existing turnouts to facilitate conveyance of water to the recharge ponds;</p> <p>Construction of overpour structures to convey water to the lower elevation diked ponds; and</p> <p>Construction of up to two (2) high production wells and a network of pipelines and appurtenances to recover water that has been previously recharged.</p> <p>During “put” operations, surface water (including floodwater originating from Poso Creek, CVP-Friant System, and surface supplies received to be stored as “banked” water) will be conveyed through the District’s existing distribution system and delivered to the recharge ponds for recharge and storage.</p> <p>During “take” operations, which is the return of previously stored water, water will be recovered through the use and operation of production wells and returned by use of the network of pipelines for ultimate delivery to the Pond Poso Canal.</p>
--

**If applicable, list surface water bodies and groundwater basins associated with the proposed project:**

<ul style="list-style-type: none"> <li>• Surface water delivered via CA Aqueduct or Friant-Kern Canal</li> </ul>
<ul style="list-style-type: none"> <li>• Poso Creek Flood Channel</li> </ul>
<ul style="list-style-type: none"> <li>• Kern Groundwater Basin</li> </ul>
<ul style="list-style-type: none"> <li>• Pond Poso Canal</li> </ul>

**Please identify up to three available documents which contain information specific to the proposed project. Include conceptual plans, permits, drawings, and technical documents:**

<ul style="list-style-type: none"> <li>• N/A</li> </ul>

Please identify federal, state, or local permits, which pertain to the proposed project and would need to be obtained or, if existing, would need to be amended:

• CEQA, IS/ND
• Dept. of Fish and Game
• Local: SJV Unified Air Pollution Control District, SWPPP NOI

Please identify any existing projects or facilities, including existing water conveyance infrastructure, which would be affected, modified, or superseded as a result of implementing the proposed project:

• N/A

Is the proposed project an element or phase of a regional or larger program?	<input checked="" type="checkbox"/> Yes <input type="checkbox"/> No
If yes, please identify the program:	<u>Poso Creek IRWMP</u>
Design life of the project:	<u>50</u>
Proposed Construction/Implementation Start Date:	<u>Yet Unknown</u>
Proposed Construction/Implementation Completion Date:	<u>Yet Unknown</u>
Ready for Construction Bid:	<input type="checkbox"/> Yes <input checked="" type="checkbox"/> No <input type="checkbox"/> N/A

Item	Status (e.g., not initiated, in process, complete)	Date (mm/dd/yyyy)
Conceptual Plans	<b>Not Initiated</b>	N/A
Land Acquisition/ Easements	<b>Not Initiated</b>	N/A
Preliminary Plans	<b>Not Initiated</b>	N/A
CEQA/NEPA	<b>Not Initiated</b>	N/A
Permits	<b>Not Initiated</b>	N/A
Construction Drawings	<b>Not Initiated</b>	N/A

For projects ready for construction or implementation, including projects which do not include construction, briefly describe the project's readiness to proceed.

**Project Readiness (Narrative)**

The Project is in the early stages of development and has been advanced into the conceptual phase. In this regard, while the property is owned in fee by the District, the Project will require completion of a CEQA environmental document, acquisition of construction-related permits, and the preparation of contract documents, including Plans and Specifications for implementation. However, this project would be similar in scope and complexity as existing District recharge and recovery facilities and could be implemented expeditiously.

Include any local or state board actions, code changes, or legislation needed in order to proceed with the project.

**Local or State Board Actions, Code Changes, or Legislation**

The Project can be implemented by Board action.

**Please describe the dominant existing land use type for the proposed project location.**

**Agricultural**

**Please describe the dominant existing land use type for areas upstream and downstream of the proposed project location**

Upstream:	Agricultural
Downstream:	Agricultural



## Part 4. Project Benefits

Please provide a one or two paragraph description of the benefit(s) that the project will address. Benefit Categories, shown below, are referenced from the [Storm Water Resource Plan Guidelines](#), Page 31, Table 4. Each project should address at least two or more Main Benefits and as many Additional Benefits as feasible. Information you provide will be used to evaluate the project for State grant funding.

Storm Water Management Benefits		
Benefit Category	Main Benefit	Additional Benefit
<b>Water Quality</b> (while contributing to compliance with applicable permit and/or TMDL requirements)	<ul style="list-style-type: none"> <li>Increased filtration and/or treatment of run-off</li> <li>Potential improvements in groundwater quality</li> </ul>	<ul style="list-style-type: none"> <li>Non-point source pollution control</li> <li>Reestablished natural water drainage and treatment</li> </ul>
<b>Water Supply</b> (through groundwater management and/or run-off capture and use)	<ul style="list-style-type: none"> <li><b>Water supply reliability</b></li> <li><b>Expand Conjunctive use</b></li> <li><b>Reduce short-term groundwater level declines</b></li> </ul>	<ul style="list-style-type: none"> <li>Water conservation</li> </ul>
<b>Flood Management</b>	<ul style="list-style-type: none"> <li><b>Decreased flood risk by reducing run-off rate and/or volume</b></li> </ul>	<ul style="list-style-type: none"> <li>Reduced sanitary sewer overflows</li> </ul>
<b>Environmental and Habitat Enhancement</b>	<ul style="list-style-type: none"> <li>Environmental and habitat protection and improvement, including;                             <ul style="list-style-type: none"> <li>wetland enhancement/creation;</li> <li>riparian enhancement; and/or</li> <li>instream flow improvement</li> </ul> </li> <li>Increased urban green space</li> </ul>	<ul style="list-style-type: none"> <li>Reduced energy use, greenhouse gas emissions, or provides a carbon sink</li> <li>Reestablishment of the natural hydrograph</li> <li>Water temperature improvements</li> </ul>
<b>Community Stewardship</b>	<ul style="list-style-type: none"> <li>Employment opportunities provided</li> <li>Public Education</li> </ul>	<ul style="list-style-type: none"> <li>Community involvement</li> <li>Enhance and/or create recreational and public use areas</li> </ul>

Source: Page 31, Table 4, Storm Water Resource Plan Guidelines, State Water Resources Control Board

Please provide the following **PROJECT BENEFIT** information for all applicable components of the proposed project. Benefit categories include:

- **Water Quality**
- **Water Supply**
- **Flood Management**
- **Environmental and Habitat Enhancement**
- **Community Stewardship**

If the project benefits a disadvantaged community (DAC) describe the specific benefits to that community. Estimate the percentage of the project benefits to the DAC.

Please supply all information relevant to the proposed project. The information you provide will be used to evaluate the project for State grant funding. **Attach additional sheets if necessary.**

## Water Quality Benefits

1. Describe how the proposed project will improve source control for both pollution and dry weather runoff volume, onsite and local infiltration, and use of storm water and dry weather runoff.
2. Describe design criteria and best management practices to prevent storm water and dry weather runoff pollution and increase effective storm water and dry weather runoff management for new and upgraded infrastructure and residential, commercial, industrial, and public development
3. Describe how the proposed project complies with or is consistent with an applicable NPDES permit. The analysis should simulate the proposed watershed-based outcomes using modeling, calculations, pollutant mass balances, water volume balances, and/or other methods of analysis. Describe how the proposed project will contribute to the preservation, restoration, or enhancement of watershed processes (as described in Guidelines section VI.C.2.a)
4. Describe the water quality monitoring and data acquisition that will be implemented in conjunction with the proposed project. Describe the a) mechanisms by which data will be managed and stored; b) how data will be accessed by stakeholders and the public; c) how existing water quality and water quality monitoring will be assessed; d) frequency at which data will be updated; and e) how data gaps will be identified.

### Water Quality Benefits (Narrative)

<p>Water quality benefits would not apply as a primary benefit for this project. However, recharge basins within the District allow for direct recharge of surface water originating from the SWP, the CVP, Kern River, and the local Poso Creek that has varying “raw” untreated, water quality characteristics, usually suitable for irrigation. Local Stormwater may also originate from the Poso Creek and is diverted through settlement basins prior to entering the District distribution system and delivered to spreading grounds. The sources vary in quality, but are all typically suitable for irrigation and do not degrade the groundwater basin from its designated use.</p> <p>It is recognized in the Poso Creek IRWMP area that the majority of recharge facilities are constructed and operated by the agricultural districts and not by the small disadvantaged communities or the environmental water users, this project also has the potential to improve water quality as follows:</p> <ul style="list-style-type: none"> <li>• Enhancement of groundwater quality due to decreased pumping lifts and stabilization of the water table, which reduces the chances of water quality changing due to pumping from zones of less quality; and</li> <li>• Enhancements to water quality due to the importation of surface water to the District in wet years, which delivers surface water of quality suitable for the beneficial uses within the region.</li> </ul>	
Pollutant TMDL reduction (Volume per day) and (mass /unit volume) of most probable number of bacteria or indicator organisms (mpn/mL):	<u>Unknown</u>
Increase in infiltration rate above existing condition:	<u>A portion of 70 acres will be developed into recharge basins allowing for an increase in the District’s absorptive capacity.</u>
Non-point source pollution control:	<u>Unknown</u>
Does project affect an Existing NPDES Permit? If applicable, describe the need for a new NPDES Permit:	<u>Unknown</u>

## Water Supply Benefits

1. Describe how the proposed project captures and reuses storm water and dry weather runoff for groundwater recharge or storage for beneficial use.
2. Please provide detailed information to quantify how the proposed project will reduce existing potable water demand.
3. Describe the water supply monitoring and data acquisition that will be implemented in conjunction with the proposed project. Describe the a) mechanisms by which data will be managed and stored; b) how data will be accessed by stakeholders and the public; c) how existing water quality and water quality monitoring will be assessed; d) frequency at which data will be updated; and e) how data gaps will be identified

### Water Supply Benefits (Narrative)

The Project, once fully developed, will provide the following estimated water supply benefits:

- 1) An estimated quantifiable water savings of 245 acre-feet per year based on the conversion of agricultural land to retention ponds (the estimated water savings per year is based on 70 gross acres of cropland with an applied water use of 3.5 acre-feet per year being converted to non-cropland;
- 2) An additional 35 acre-feet per day capacity for aquifer recharge when the area is wet and in use as recharge ponds (estimated rate of recharge is at minimum 0.5 acre-feet per day); and
- 3) Estimated capacity for a wet year of 1,658AFY ( $=70/800 * 18,954 \text{ AF} = 1,658 \text{ AFY}$ , based on comparison ratio of yield of PPSG (@ 800 acres)).

Additionally, the project would:

- Improve the reliability of water supply for Semitropic.
- Increase operational flexibility for delivery of State Water Project (SWP) water
- Increase direct spreading, absorptive capability within Semitropic
- Increase local unconfined groundwater quality.
- Make use of available groundwater storage.
- Contribute to the groundwater basin for use during periods of peak demand or when SWP water is not available.

### Enhanced Water Supply or Demand Reduction Benefit Information

Source of Increased Supply or Demand Reduction	
<input checked="" type="checkbox"/> Groundwater	<input type="checkbox"/> Groundwater treatment
<input type="checkbox"/> Recycled water	<input checked="" type="checkbox"/> Conservation/ water use efficiency
<input type="checkbox"/> Transfer	<input type="checkbox"/> Other (describe):
<input checked="" type="checkbox"/> Increased surface water storage	<input type="checkbox"/> Ocean desalination
Type of enhanced supply or demand reduction:	Recharged groundwater
Annual Yield of Supply (acre-feet):	577AFY = 332AFY + 245AFY based on removal of crop demand plus delivery of surface supplies to the Shuster SGs similar to the PPSGs at a frequency of 2 wet years out of 10 years
Availability by Water-Year Type (acre-feet per year)	
Average Year:	$577\text{AFY} = 332 \text{ AFY} + 245\text{AFY}; [ 332 \text{ AFY} = 1,658 \text{ AF} * ( 2 \text{ wet years} / 10 \text{ years} ) ]$
Dry Year:	<u>245AFY</u>

Wet Year:	<u>1,903AFY = 1,658 AFY + 245AFY</u>		
<b>Availability by Season (check all that apply):</b>			
<input checked="" type="checkbox"/> Summer	<input checked="" type="checkbox"/> Fall	<input checked="" type="checkbox"/> Spring	<input checked="" type="checkbox"/> Winter
<b>Does the project have the potential to reduce demands on the Bay/Delta/Estuary?</b>			
<input checked="" type="checkbox"/> Yes	<input type="checkbox"/> No	<input type="checkbox"/> Not Sure	

### Flood Management Benefits

1. Describe how the proposed project will reestablish natural water drainage treatment and infiltration systems, or mimic natural system functions to the maximum extent feasible.
2. Describe how the proposed project will reduce flood risk by reducing runoff rate and/or volume.
3. If applicable, describe how the proposed project will reduce the risk of sanitary sewer overflows.

### Flood Management Benefits (Narrative)

<p>The Project provides a flood management benefit inasmuch as the water delivered to the direct recharge facility during times of storm water/floodwater management will be diverted and not contribute to increased downstream flows and flood risks. In the case of Semitropic’s Water Bank and direct recharge facility, flood flow is delivered via the CA Aqueduct into the District’s conveyance system, or, it is delivered via Poso Creek as diverted CVP-Friant or locally, Poso Creek Stormwater, therefore, the added absorptive capacity of direct recharge enhances the ability to receive flows during wet periods, typically corresponding to times of the year when irrigation demand is low. This Project enhances flood management of the CA Aqueduct in reducing flood risk by allowing diversions into the CA Aqueduct, upstream of the Semitropic turnout.</p>	
Description facilities protected:	Potentially regional conveyance facilities and facilities/land along Poso Creek
Maximum volume of temporary storage of storm water runoff (acre-feet):	224 (based on 56 wetted acres x 4 feet deep)
Maximum increased conveyance capacity (cubic feet/second):	20 (based on modifications of four existing turnouts @ 5cfs/turnout)
Estimated area benefiting from flood damage reduction (acres):	Immediate local drainage of Poso Creek
Estimated level of flood protection resulting from project implementation (% annual probability of recurrence or 1-in-number of years recurrence):	Unknown
Estimated annual value of flood damage reduction provided by project (\$/year):	Unknown
Land required for project implementation (acres):	70 acres, owned by the District

### For projects that include detention and groundwater recharge, please complete the following:

How many acres of land drain into this detention basin? (acres):	N/A
Detention Basin area (acres):	70 gross acres, with 56 wetted acres

Detention basin max. operational depth (ft.):	4
% of basin covered by wetlands:	N/A
Soil type:	Loam
If other than infiltration, identify method (e.g., injection) and recharge (acre-feet/year):	N/A
Estimated basin annual inflow (acre-feet/year):	332
Estimated basin annual outflow (acre-feet/year):	0

## Environmental and Habitat Enhancement Benefits

Describe how the proposed project identifies opportunities to develop, restore, or enhance habitat and open space through storm water and dry weather runoff management, including wetlands, riverside habitats, parkways, and parks. Provide some type of quantitative measurement, which will show how the project benefits the environment and enhances the natural habitat.

### Environmental and Habitat Enhancement Benefits (Narrative)

The Project will provide waterfowl with a place to rest and nest, intermittently, when they have water in the ponds and are being utilized for recharge purposes.

Non-treatment wetland area (acres):	<u>56 acres (70 gross acres x 80% wetted area), only when being used for direct recharge</u>
Treatment wetland area (acres):	<u>N/A</u>
Riparian habitat area (acres):	<u>N/A</u>
Non-developed open space area (acres):	<u>14 acres = (70 gross acres – 56 wetted acres)</u>
Total Project area (acres):	<u>70 gross acres</u>

## Community Stewardship Benefits

Describe how the project identifies opportunities to use existing publicly owned lands and easements, including, but not limited to parks, open space, community gardens, farm and agricultural preserves, school sites, and government office buildings and complexes, to capture, clean, store, and use storm water and dry weather runoff either onsite or offsite. Provide some type of quantitative measurement, which will show how the project benefits the community.

### Community Stewardship Benefits (Narrative)

<p>The Project will provide jobs during construction. Once constructed, the facility provides a habitat for various birds and waterfowl that also provides an opportunity for the public to view the birds.</p>
---

**Multiple use/ recreation area (acres) – additionally, select the type of multiple use / recreation and associated acres by type:**

Single Sport Athletics:	<u>N/A</u>
Multiple Sport Athletics Acres:	<u>N/A</u>
Other Recreation Acres:	<u>N/A</u>
Pedestrian Trail Acres:	<u>N/A</u>
Equestrian Trail Acres:	<u>N/A</u>
Other Passive Activity:	<u>Bird Viewing</u>
Other Acres (describe):	<u>N/A</u>
Description:	<u>N/A</u>
<b>Total Project Area (acres):</b>	<u>70</u>

## Part 5. Project Cost Estimate

Project cost information is needed to assist in comparing benefits and cost. Additionally, knowledge of the project type and cost will assist in identifying funding sources for potential projects.

Please indicate the estimated costs of project implementation and associated funding source(s). These costs should include land purchase/easement, planning/design/engineering, construction/ implementation, environmental compliance, administration, and contingency.

<b>Approximate Total Cost:</b> (If project costs are variable, please include lower and upper range estimates.)	Approximately \$875,000 (estimated based on recent conversion of land to spreading basins and the property already owned by the District)
<b>Funding Source:</b> (If multiple sources, list each source and the percent or amount funded by each)	<ul style="list-style-type: none"> <li>• Potential future grant funding;</li> <li>• District Assessments</li> </ul>
<b>Maximum Funding Match from Implementing Agency:</b>	N/A
<b>Funding Certainty &amp; Longevity:</b>	Unknown
<b>Operations &amp; Maintenance Cost:</b> (per year)	Unknown
<b>Operations &amp; Maintenance Funding Source(s)</b> (i.e., annual budget, grant, etc. If multiple sources, list each source and the percent or amount funded by each.)	Annual Budget
<b>Operations &amp; Maintenance Funding Certainty:</b> (i.e., already included in organization's budget, contingent upon grant, etc.)	Included as part of setting of annual budget



# Kern Storm Water Resource Plan

## Project Submittal Form

This form is to be electronically filled out and e-mailed to [LMarino@ppeng.com](mailto:LMarino@ppeng.com) by June 24, 2016.

Reference: [Storm Water Resource Plan Guidelines](#), December 15, 2015  
State Water Resources Control Board

### Part 1. Lead Implementing Agency/Organizational Information

Please provide the following information regarding the project sponsor and proposed project.

**Implementing Agency / Organization / Individual:**

Semitropic Water Storage District

**Agency / Organization / Individual Address:**

1101 Central Ave, Wasco, CA 93280

**Possible Partnering Agencies:**

**Name:**

Jason Gianquinto

**Title:**

General Manager

**Telephone:**

661-758-5113

**Fax:**

661-758-3219

**Email:**

[mail@semitropic.com](mailto:mail@semitropic.com)

**Website:**

[www.semitropic.com](http://www.semitropic.com)

**Project Name:**

Pond-Poso Spreading Grounds, Phase 2

Either the latitude/longitude or a location description is required. To determine the latitude/longitude, use the closest address or intersection. If the project is linear, use the furthest upstream latitude/longitude.

**Project Latitude:**  **Project Longitude:**

<b>Location Description:</b>	The Project is 7miles northwest of Wasco, adjacent to, and west and north of the existing Pond-Poso Spreading Grounds, Phase I; south half of Section 8 and west half of Section 17, Township 26 South, Range 24 East, MDB&M.
------------------------------	---

**Project Cooperating Agency(ies)/Organization(s)/Individual(s):**

- |  |
|--|
| <ul style="list-style-type: none"><li>• Potentially Banking Partners</li></ul> |
| <ul style="list-style-type: none"><li>• Neighboring Water Districts</li></ul>  |
| <ul style="list-style-type: none"><li>•</li></ul>                              |
| <ul style="list-style-type: none"><li>•</li></ul>                              |

**Project Status (e.g., new, ongoing, expansion, new phase):**

**Has the Project been submitted to IRWM Plan:**

Kern IRWMP  Poso Creek IRWMP  Not Submitted

**Does the project address any known environmental justice issues?**

Yes  No  Not Sure

**Is the project located within or adjacent to a disadvantaged community (DAC)? Refer to this [website](#).**

Within  Adjacent  No  Not Sure

**Does the project include DAC participation?**

Yes  No  Not Sure

If yes, please identify the contact person, group, or organization and describe the DAC's participation:

**What is the DAC's estimated population?**

Does the Implementing Agency own the land where the project is located? If no, describe ability to purchase land or if eminent domain is required:

Yes  No

## Part 2. Project Need

It is important to understand the need(s) or issue(s) that the proposed project will address and the benefits that it will provide. Information provided in this section defines the need(s) or issue(s) that the proposed project will address and will help to catalog existing need(s) or issue(s) in the planning area of the Kern Storm Water Resource Plan.

Please provide a 1-2 paragraph description of the need(s) or problem(s) that the proposed project will address. Discuss the benefits to water quality, water supply, flood management, environmental, and community benefits that the proposed project will bring. Discuss critical impacts or worsening conditions that will occur if the proposed project is not implemented.

### Project Need (Narrative)

The Pond Poso Spreading Grounds (PPSG): Phase 2 (the Project), is a component of the Semitropic Groundwater Bank and will enhance the operation of the Bank. Since its inception, the Semitropic Groundwater Bank has provided long-term underground storage of water for use by the banking partners in times of need. The banking of water has been limited to “in-lieu” recharge wherein the District satisfies an irrigation demand with surplus water from its banking partners “in-lieu” of farmers pumping (leaving a like amount in groundwater storage). This method of banking has been limited to periods when the banking partners’ water supplies have not exceeded the ability to absorb the surface water by delivery to an irrigation demand. The Project will allow the District to absorb and manage the water when surface water supplies exceed the ability to deliver and absorb the surface water with an irrigation demand.

This Project adds four quarter-sections to an existing five quarter-sections in size recharge and extraction facility. Once all nine quarter-sections are fully completed, it will have a direct recharge capacity to receive up to 350 cubic feet per second (cfs) (equivalent to 700 acre-feet per day or 21,000 acre-feet per month during a wet period or opportunistic time to bank water supplies) and place up to 65,000 acre-feet of water into storage in any given wet year more efficiently (based on three months of use in a given “wet year”). The Project would also provide for recovery of stored water. When the Project is fully completed, it will provide for the recovery of about 66,000 acre-feet per year (based on 10 months of pumping and 10 percent downtime).

The Project will also provide for flood management benefits inasmuch as it will accommodate diversion of flood flows from the Poso Creek Flood Channel, through the Poso Creek intake and control structure, which conveys water from Poso Creek into the Pond Poso Canal and ultimately into the Project.

The primary purpose of the Project is to improve the sustainability of the local water supplies and conjunctively manage the surface and groundwater resource for the benefit of the area. The need results from a number of actions which have served to reduce the historical reliability of water supplies available to the region.

### Part 3. Project Description

A general description of the proposed project is needed. This section will provide information associated with the project concept and general project information. Much of the requested information may not be available for projects that are in the conceptual stages of development. An essential element of the Kern Storm Water Resource Plan consists of proposed projects. We appreciate and need your ideas.

Please provide a one or two paragraph description of the project including the general project concept, what will be constructed/implemented, how the constructed project will function, what technologies or methods will be used, as appropriate. For water quality projects, include a description of impacts to existing Total Maximum Daily Loads, NPDES permits, and/or waste discharge requirements.

**Project Description (Narrative)**

The Project consists of the following facilities:

The conversion of 640 gross acres into diked recharge ponds, with up to 16 “cells”;

Construction of a 8’x8’ reinforced concrete diversion box with 48-inch RCP pipe oriented to the West to lift water from the Pond Poso Canal to the westerly recharge ponds;

Modification of existing pump structures on the Pond Poso Canal (PPC) to facilitate lifting of water into the northerly recharge ponds, at other locations within the PPC;

Construction of pond structures, including up to 25 interbasin structures and up to 15 pond overpour structures to convey water to the lower elevation recharge ponds;

Construction of emergency spillways located on the lowest tiers of the recharge ponds, adjacent to the Poso Creek Flood Channel to overflow water into the creek in the event the inflow into the recharge ponds exceeds the ponds capacity;

At several locations, construction of double barrel siphon pipe crossings of the Pond Poso Canal;

Widening of two miles of the Pond Poso Canal for that portion running through the PPSG;

Construction of 12 flowpath wells and a network of pipelines and appurtenances to recover water that has been previously recharged; and

Construction of 4 monitoring wells to monitor water levels.

During “put” operations, surface water (including floodwater originating from Poso Creek, CVP-Friant System, and banked water) will be lifted from the Pond Poso Canal and delivered to the recharge ponds for recharge. Water will be conveyed through the recharge ponds via interbasin structures and overpour structures to the lower elevation ponds.

During “take” operations, water will be recovered through the use and operation of flowpath wells and the network of pipelines for ultimate delivery to the Pond Poso Canal.

**If applicable, list surface water bodies and groundwater basins associated with the proposed project:**

<ul style="list-style-type: none"> <li>• Surface water delivered via CA Aqueduct or Friant-Kern Canal</li> </ul>
<ul style="list-style-type: none"> <li>• Poso Creek Flood Channel</li> </ul>
<ul style="list-style-type: none"> <li>• Kern Groundwater Basin</li> </ul>
<ul style="list-style-type: none"> <li>• Pond Poso Canal</li> </ul>

Please identify up to three available documents which contain information specific to the proposed project. Include conceptual plans, permits, drawings, and technical documents:

• CEQA Document (IS/ND) Prepared in 2007
• Federal funded ARRA grant for completion of Phase 1
•

Please identify federal, state, or local permits, which pertain to the proposed project and would need to be obtained or, if existing, would need to be amended:

• Update CEQA for GHG Emissions
• Dept. of Fish & Game
• Local: SJV Unified Air Pollution Control District, SWPPP NOI

Please identify any existing projects or facilities, including existing water conveyance infrastructure, which would be affected, modified, or superseded as a result of implementing the proposed project:

• Pond Poso Spreading Grounds would be expanded to Phase II
• Pond Poso Canal
• Poso Creek Flood Channel

Is the proposed project an element or phase of a regional or larger program?	<input checked="" type="checkbox"/> Yes <input type="checkbox"/> No
If yes, please identify the program:	<u>Poso Creek IRWMP</u>
Design life of the project:	<u>50</u>
Proposed Construction/Implementation Start Date:	<u>Yet Unknown</u>
Proposed Construction/Implementation Completion Date:	<u>Yet Unknown</u>
Ready for Construction Bid:	<input type="checkbox"/> Yes <input checked="" type="checkbox"/> No <input type="checkbox"/> N/A

Item	Status (e.g., not initiated, in process, complete)	Date (mm/dd/yyyy)
Conceptual Plans	<b>Complete</b>	05/10/2010
Land Acquisition/ Easements	<b>Complete</b>	
Preliminary Plans	<b>Complete</b>	
CEQA/NEPA	<b>CEQA completed in 2007; update for GHG may be needed. NEPA would be required if a federal nexus exists.</b>	
Permits	<b>Normal CEQA compliance</b>	
Construction Drawings	<b>Preliminary drawings have been prepared.</b>	

For projects ready for construction or implementation, including projects which do not include construction, briefly describe the project's readiness to proceed.

**Project Readiness (Narrative)**

Phase 2 of the Pond Poso Spreading Grounds is ready to implement since the District owns the property and can obtain access fairly quickly. The design of Phase 2 will be based on the completed design for Phase 1, which will allow for an accelerated schedule once funding is secured to complete the construction. If federal funding was secured, it will require completing NEPA documentation prior to construction.

Include any local or state board actions, code changes, or legislation needed in order to proceed with the project.

**Local or State Board Actions, Code Changes, or Legislation**

Phase 2 of the Pond Poso Spreading Grounds can be implemented by Board action.

**Please describe the dominant existing land use type for the proposed project location.**

**Agricultural**

**Please describe the dominant existing land use type for areas upstream and downstream of the proposed project location**

Upstream:	Agricultural
Downstream:	Agricultural/Spreading Grounds

## Part 4. Project Benefits

Please provide a one or two paragraph description of the benefit(s) that the project will address. Benefit Categories, shown below, are referenced from the [Storm Water Resource Plan Guidelines](#), Page 31, Table 4. Each project should address at least two or more Main Benefits and as many Additional Benefits as feasible. Information you provide will be used to evaluate the project for State grant funding.

Storm Water Management Benefits		
Benefit Category	Main Benefit	Additional Benefit
<b>Water Quality</b> (while contributing to compliance with applicable permit and/or TMDL requirements)	<ul style="list-style-type: none"> <li>Increased filtration and/or treatment of run-off</li> <li>Potential improvements in groundwater quality</li> </ul>	<ul style="list-style-type: none"> <li>Non-point source pollution control</li> <li>Reestablished natural water drainage and treatment</li> </ul>
<b>Water Supply</b> (through groundwater management and/or run-off capture and use)	<ul style="list-style-type: none"> <li><b>Water supply reliability</b></li> <li><b>Expand Conjunctive use</b></li> <li><b>Reduce short-term groundwater level declines</b></li> </ul>	<ul style="list-style-type: none"> <li>Water conservation</li> </ul>
<b>Flood Management</b>	<ul style="list-style-type: none"> <li><b>Decreased flood risk by reducing run-off rate and/or volume</b></li> </ul>	<ul style="list-style-type: none"> <li>Reduced sanitary sewer overflows</li> </ul>
<b>Environmental and Habitat Enhancement</b>	<ul style="list-style-type: none"> <li>Environmental and habitat protection and improvement, including;               <ul style="list-style-type: none"> <li>wetland enhancement/creation;</li> <li>riparian enhancement; and/or</li> <li>instream flow improvement</li> </ul> </li> <li>Increased urban green space</li> </ul>	<ul style="list-style-type: none"> <li>Reduced energy use, greenhouse gas emissions, or provides a carbon sink</li> <li>Reestablishment of the natural hydrograph</li> <li>Water temperature improvements</li> </ul>
<b>Community Stewardship</b>	<ul style="list-style-type: none"> <li>Employment opportunities provided</li> <li>Public Education</li> </ul>	<ul style="list-style-type: none"> <li>Community involvement</li> <li>Enhance and/or create recreational and public use areas</li> </ul>

Source: Page 31, Table 4, Storm Water Resource Plan Guidelines, State Water Resources Control Board

Please provide the following **PROJECT BENEFIT** information for all applicable components of the proposed project. Benefit categories include:

- **Water Quality**
- **Water Supply**
- **Flood Management**
- **Environmental and Habitat Enhancement**
- **Community Stewardship**

If the project benefits a disadvantaged community (DAC) describe the specific benefits to that community. Estimate the percentage of the project benefits to the DAC.

Please supply all information relevant to the proposed project. The information you provide will be used to evaluate the project for State grant funding. **Attach additional sheets if necessary.**

## Water Quality Benefits

1. Describe how the proposed project will improve source control for both pollution and dry weather runoff volume, onsite and local infiltration, and use of storm water and dry weather runoff.
2. Describe design criteria and best management practices to prevent storm water and dry weather runoff pollution and increase effective storm water and dry weather runoff management for new and upgraded infrastructure and residential, commercial, industrial, and public development
3. Describe how the proposed project complies with or is consistent with an applicable NPDES permit. The analysis should simulate the proposed watershed-based outcomes using modeling, calculations, pollutant mass balances, water volume balances, and/or other methods of analysis. Describe how the proposed project will contribute to the preservation, restoration, or enhancement of watershed processes (as described in Guidelines section VI.C.2.a)
4. Describe the water quality monitoring and data acquisition that will be implemented in conjunction with the proposed project. Describe the a) mechanisms by which data will be managed and stored; b) how data will be accessed by stakeholders and the public; c) how existing water quality and water quality monitoring will be assessed; d) frequency at which data will be updated; and e) how data gaps will be identified.

### Water Quality Benefits (Narrative)

<p>The Project also has the potential to improve water quality as follows:</p> <ul style="list-style-type: none"> <li>• Enhancement of groundwater quality due to decreased pumping lifts and stabilization of the water table, which reduces the chances of water quality changing due to pumping from zones of less quality; and</li> <li>• Enhancements to water quality due to the importation of surface water to the District in wet years, which delivers surface water of quality suitable for the beneficial uses within the region.</li> </ul>	
Pollutant TMDL reduction (Volume per day) and (mass /unit volume) of most probable number of bacteria or indicator organisms (mpn/mL):	<u>Unknown</u>
Increase in infiltration rate above existing condition:	<u>Converts 640 acres of farmed land into recharge facility.</u>
Non-point source pollution control:	<u>Unknown</u>
Does project affect an Existing NPDES Permit? If applicable, describe the need for a new NPDES Permit:	<u>Unknown</u>



## Water Supply Benefits

1. Describe how the proposed project captures and reuses storm water and dry weather runoff for groundwater recharge or storage for beneficial use.
2. Please provide detailed information to quantify how the proposed project will reduce existing potable water demand.
3. Describe the water supply monitoring and data acquisition that will be implemented in conjunction with the proposed project. Describe the a) mechanisms by which data will be managed and stored; b) how data will be accessed by stakeholders and the public; c) how existing water quality and water quality monitoring will be assessed; d) frequency at which data will be updated; and e) how data gaps will be identified

### Water Supply Benefits (Narrative)

While a precise estimate of the annual amount of Stormwater or surface supply that will be delivered for direct recharge is challenging due to uncertainties and variation in annual supply, evaluation of the project's absorptive capacity can be estimated based on the acreage of Phase 2 compared to Phase 1 and the operation of Phase 1 during a recent wet period. A reasonable estimate of the absorptive capacity for the Phase 2 recharge facility is 15,163 acre-feet per wet year since it is the development of 4 quarter sections compared to the existing developed five quarter section area of Phase 1. Phase 1 was able to absorb 18,954 acre-feet of surface supply in 2011, a wet period.  $[15,163 = (4/5) * 18,954]$

Additionally, the Project will convert 640 gross acres to ponds, resulting in an annual benefit of 2,240 AF [3.5 AFY per acre], for a total annual benefit of 5,273 AFY [  $5,273 \text{ AFY} = 2,240 \text{ AFY} + 3,033 \text{ AFY}$  ]

The Project would also:

- Improve the reliability of water supply for Semitropic.
- Increase operational flexibility for delivery of State Water Project (SWP) water
- Increase direct spreading, absorptive capability within Semitropic
- Increase local unconfined groundwater quality.
- Make use of available groundwater storage.
- Contribute to the groundwater basin for use during periods of peak demand or when SWP water is not available.

### Enhanced Water Supply or Demand Reduction Benefit Information

Source of Increased Supply or Demand Reduction	
<input checked="" type="checkbox"/> Groundwater	<input type="checkbox"/> Groundwater treatment
<input type="checkbox"/> Recycled water	<input checked="" type="checkbox"/> Conservation/ water use efficiency
<input type="checkbox"/> Transfer	<input type="checkbox"/> Other (describe):
<input checked="" type="checkbox"/> Increased surface water storage	<input type="checkbox"/> Ocean desalination
Type of enhanced supply or demand reduction:	Recharged groundwater
Annual Yield of Supply (acre-feet):	3,033 AFY based on delivery to Phase 2 at a frequency of 2 out of 10 years
Availability by Water-Year Type (acre-feet per year)	
Average Year:	$5,273 \text{ AFY} = 2,240 \text{ AFY} + 3,033 \text{ AFY}$ ; $15,163 [ 2 \text{ wet years} / 10 \text{ years}] = 3,033 \text{ AF}$
Dry Year:	<u>2,240 AF</u>

Wet Year:	17,403 AFY = 15,163 AFY + 2,240 AFY; based on 2011 deliveries to existing PPSG, plus 2,240 AFY due to saved water from retired agricultural land.		
<b>Availability by Season (check all that apply):</b>			
<input checked="" type="checkbox"/> Summer	<input checked="" type="checkbox"/> Fall	<input checked="" type="checkbox"/> Spring	<input checked="" type="checkbox"/> Winter
<b>Does the project have the potential to reduce dependence on the Sacramento San Joaquin Bay/Delta/Estuary-Delta?</b>			
<input checked="" type="checkbox"/> Yes	<input type="checkbox"/> No	<input type="checkbox"/> Not Sure	

### Flood Management Benefits

1. Describe how the proposed project will reestablish natural water drainage treatment and infiltration systems, or mimic natural system functions to the maximum extent feasible.
2. Describe how the proposed project will reduce flood risk by reducing runoff rate and/or volume.
3. If applicable, describe how the proposed project will reduce the risk of sanitary sewer overflows.

### Flood Management Benefits (Narrative)

<p>The Project provides a flood management benefit inasmuch as the water delivered to the direct recharge facility during times of Stormwater management will be diverted and not contribute to increased downstream flows and flood risks. In the case of Semitropic's Water Bank and direct recharge facility, flood flow is delivered via the CA Aqueduct into the District's conveyance system, or, it is delivered via Poso Creek as diverted CVP-Friant or Poso Creek Stormwater, therefore, the added absorptive capacity of direct recharge enhances the ability to receive flows during wet periods, typically corresponding to times of the year when irrigation demand is low. This Project enhances flood management of the CA Aqueduct in reducing flood risk by allowing diversions into the CA Aqueduct, upstream of the Semitropic turnout.</p> <p>Additionally, the Project also provides for a flood management benefit with the ability to divert wet-year water from Poso Creek into the recharge ponds. During flood events on Poso Creek, the recharge ponds could take occurring flood flows, thereby reducing flood damage within the Kern NWR and adjacent valuable agriculture lands.</p>	
Description facilities protected:	Regional conveyance facilities and facilities/land along Poso Creek.
Maximum volume of temporary storage of storm water runoff (acre-feet):	15,163
Maximum increased conveyance capacity (cubic feet/second):	350
Estimated area benefiting from flood damage reduction (acres):	Unknown, qualitatively estimated to be all agricultural lands adjacent to the Poso Creek Flood Channel and the Kern NWR, which have historically been flooded during major flooding events.
Estimated level of flood protection resulting from project implementation (% annual probability of recurrence or 1-in-number of years recurrence):	Unknown
Estimated annual value of flood damage reduction provided by project (\$/year):	Unknown

Land required for project implementation (acres):	640, owned by the District.
---	-----------------------------

**For projects that include detention and groundwater recharge, please complete the following:**

How many acres of land drain into this detention basin? (acres):	
Detention Basin area (acres):	640 gross acres, with 512 net acres
Detention basin max. operational depth (ft.):	4
% of basin covered by wetlands:	N/A
Soil type:	Loam
If other than infiltration, identify method (e.g., injection) and recharge (acre-feet/year):	<u>15,163 AF/year</u> ; based on 2011 deliveries to existing PPSG.
Estimated basin annual inflow (acre-feet/year):	3,033 AF/year
Estimated basin annual outflow (acre-feet/year):	0 AF/year

## Environmental and Habitat Enhancement Benefits

Describe how the proposed project identifies opportunities to develop, restore, or enhance habitat and open space through storm water and dry weather runoff management, including wetlands, riverside habitats, parkways, and parks. Provide some type of quantitative measurement, which will show how the project benefits the environment and enhances the natural habitat.

### Environmental and Habitat Enhancement Benefits (Narrative)

The Pond Poso Spreading Grounds has the potential to create seasonal or intermittent shallow open water habitat by providing benefits for upland habitat through the construction of habitat benches, which consist of enlarged earthen benches up to 80-feet wide to support waterfowl with a place to rest and nest, when they have water in the ponds and are being utilized for recharge purposes.

Non-treatment wetland area (acres):	<u>512 acres (640 acres x 80% wetted area), only when being used for direct recharge</u>
Treatment wetland area (acres):	<u>N/A</u>
Riparian habitat area (acres):	<u>N/A</u>
Non-developed open space area (acres):	<u>128 acres = (640 gross acres – 512 wetted acres)</u>
Total Project area (acres):	<u>640 gross acres</u>

## Community Stewardship Benefits

Describe how the project identifies opportunities to use existing publicly owned lands and easements, including, but not limited to parks, open space, community gardens, farm and agricultural preserves, school sites, and government office buildings and complexes, to capture, clean, store, and use storm water and dry weather runoff either onsite or offsite. Provide some type of quantitative measurement, which will show how the project benefits the community.

### Community Stewardship Benefits (Narrative)

<p>The Project has the potential for providing project benefits to the community as described below. Once constructed, the facility provides a habitat for various birds and waterfowl that also provides an opportunity for the public to view the waterfowl.</p>
--

**Multiple use/ recreation area (acres) – additionally, select the type of multiple use / recreation and associated acres by type:**

Single Sport Athletics:	<u>N/A</u>
Multiple Sport Athletics Acres:	<u>N/A</u>
Other Recreation Acres:	<u>N/A</u>
Pedestrian Trail Acres:	<u>N/A</u>
Equestrian Trail Acres:	<u>N/A</u>
Other Passive Activity:	<u>Bird viewing</u>
Other Acres (describe):	<u>N/A</u>
Description:	<u>N/A</u>
<b>Total Project Area (acres):</b>	<u>640</u>

## Part 5. Project Cost Estimate

Project cost information is needed to assist in comparing benefits and cost. Additionally, knowledge of the project type and cost will assist in identifying funding sources for potential projects.

Please indicate the estimated costs of project implementation and associated funding source(s). These costs should include land purchase/easement, planning/design/engineering, construction/ implementation, environmental compliance, administration, and contingency.

<b>Approximate Total Cost:</b> (If project costs are variable, please include lower and upper range estimates.)	\$10,000,000+
<b>Funding Source:</b> (If multiple sources, list each source and the percent or amount funded by each)	<ul style="list-style-type: none"> <li>• Potential future grant funding;</li> <li>• Banking Partners;</li> <li>• District Assessments</li> </ul>
<b>Maximum Funding Match from Implementing Agency:</b>	N/A
<b>Funding Certainty &amp; Longevity:</b>	Unknown
<b>Operations &amp; Maintenance Cost:</b> (per year)	Unknown
<b>Operations &amp; Maintenance Funding Source(s)</b> (i.e., annual budget, grant, etc. If multiple sources, list each source and the percent or amount funded by each.)	Annual Budget
<b>Operations &amp; Maintenance Funding Certainty:</b> (i.e., already included in organization's budget, contingent upon grant, etc.)	Included as part of setting of annual budget

# Kern Storm Water Resource Plan

## Project Submittal Form

This form is to be electronically filled out and e-mailed to [LMarino@ppeng.com](mailto:LMarino@ppeng.com) by June 24, 2016.

Reference: [Storm Water Resource Plan Guidelines](#), December 15, 2015  
State Water Resources Control Board

### Part 1. Lead Implementing Agency/Organizational Information

Please provide the following information regarding the project sponsor and proposed project.

**Implementing Agency / Organization / Individual:**

Semitropic Water Storage District

**Agency / Organization / Individual Address:**

1101 Central Ave, Wasco, CA 93280

**Possible Partnering Agencies:**

**Name:**

Jason Gianquinto

**Title:**

General Manager

**Telephone:**

661-758-5113

**Fax:**

661-758-3219

**Email:**

[mail@semitropic.com](mailto:mail@semitropic.com)

**Website:**

[www.semitropic.com](http://www.semitropic.com)

**Project Name:**

Stored Water Recovery Unit, Element of the Semitropic Groundwater Bank

Either the latitude/longitude or a location description is required. To determine the latitude/longitude, use the closest address or intersection. If the project is linear, use the furthest upstream latitude/longitude.

**Project Latitude:**  **Project Longitude:**

<b>Location Description:</b>	Within the northwest area of the SWSD, about 4 miles south of the north Kern County line
------------------------------	--

**Project Cooperating Agency(ies)/Organization(s)/Individual(s):**

- |  |
|--|
| <ul style="list-style-type: none"><li>• Potentially Banking Partners</li></ul> |
| <ul style="list-style-type: none"><li>• Neighboring Water Districts</li></ul>  |
| <ul style="list-style-type: none"><li>•</li></ul>                              |
| <ul style="list-style-type: none"><li>•</li></ul>                              |

**Project Status (e.g., new, ongoing, expansion, new phase):**

**Has the Project been submitted to IRWM Plan:**

Kern IRWMP  Poso Creek IRWMP  Not Submitted

**Does the project address any known environmental justice issues?**

Yes  No  Not Sure

**Is the project located within or adjacent to a disadvantaged community (DAC)? Refer to this [website](#).**

Within  Adjacent  No  Not Sure

**Does the project include DAC participation?**

Yes  No  Not Sure

If yes, please identify the contact person, group, or organization and describe the DAC's participation:

**What is the DAC's estimated population?**

Does the Implementing Agency own the land where the project is located? If no, describe ability to purchase land or if eminent domain is required:

Yes  No



## Part 2. Project Need

It is important to understand the need(s) or issue(s) that the proposed project will address and the benefits that it will provide. Information provided in this section defines the need(s) or issue(s) that the proposed project will address and will help to catalog existing need(s) or issue(s) in the planning area of the Kern Storm Water Resource Plan.

Please provide a 1-2 paragraph description of the need(s) or problem(s) that the proposed project will address. Discuss the benefits to water quality, water supply, flood management, environmental, and community benefits that the proposed project will bring. Discuss critical impacts or worsening conditions that will occur if the proposed project is not implemented.

### Project Need (Narrative)

The Stored Water Recovery Unit (SWRU) is an element of the highly-recognized Semitropic Groundwater Banking Project. This large groundwater storage and conjunctive use project consists of expanding the recharge and recovery capacity of the Groundwater Bank by 650,000 acre-feet of storage and up to 200,000 acre-feet of recovery capability. The SWRU will enhance the District's ability to capture and store available water supplies through the addition of roughly 12,000 acres of in-lieu recharge facilities, lands currently relying exclusively on pumped groundwater, increasing the District's recharge capacity to approximately 400,000 acre-feet per year.

The Project utilization of available SWRU storage and recovery capacity will facilitate expanded conjunctive use opportunities within the District, allowing for more storage and conservation of water in wet years and greater recovery of banked water in dry periods. The SWRU benefits include additional capacity to absorb available surface supplies into the District and into the groundwater basin. Delivery of surface water supply increases groundwater levels which benefits the water quality of all users within the shared groundwater, which includes environmental, small communities, prisons, and agriculture. Increasing the absorptive capacity for delivery of surface water also provides an additional flood management benefit by allowing another place for surface water to be delivered during times of high flow.

The banking of supplemental surface waters in the aquifers underlying the District's service area provides an effective way to reduce short-term groundwater level declines.

Other advantages of groundwater banking include short-term decreases in pumping costs related to a reduction in pumping lift and a long-term benefit from the capture of additional water permanently retained in Semitropic, which occurs when banking facilities are not being utilized for banking purposes.

The primary purpose of the Project is to improve the sustainability of the local water supplies and conjunctively manage the surface and groundwater resource for the benefit of the area. The need results from a number of actions which have served to reduce the historical reliability of water supplies available to the region.

## Part 3. Project Description

A general description of the proposed project is needed. This section will provide information associated with the project concept and general project information. Much of the requested information may not be available for projects that are in the conceptual stages of development. An essential element of the Kern Storm Water Resource Plan consists of proposed projects. We appreciate and need your ideas.

Please provide a one or two paragraph description of the project including the general project concept, what will be constructed/implemented, how the constructed project will function, what technologies or methods will be used, as appropriate. For water quality projects, include a description of impacts to existing Total Maximum Daily Loads, NPDES permits, and/or waste discharge requirements.

### Project Description (Narrative)

The project consists of the following facilities:

North South Conveyance System consisting of a bidirectional pipeline/canal (including a jack and bore crossing of Highway 46) with an in-line booster pumping plant;

3 in-lieu distribution systems (System X, Y, and Z) consisting of approximately 45 miles of distribution pipeline ranging in diameter from 15 inches to 66 inches consisting of reinforced concrete pipe (> 21-inch) and PVC pipe (15-inch and 18-inch) and 80 turnouts;

3 large capacity pumping plants at the juncture of each distribution system (P.P. X - 115 cfs, P.P. Y - 80 cfs and P.P. Z - 75 cfs);

In-line booster pumping plant for System X (30cfs);

Well field consisting of 65 high production wells, 20 miles of well-field collector pipeline, 18 miles of 12kV overhead electrical power lines, and 22 miles of access roads;

Regulating Reservoir, Regulation Reservoir Pumping Plant and Poso Creek Overpour and Control Structure; and

Interconnections between systems.

Below is a summary of the function of the facilities:

North-South Conveyance System- The North-South Conveyance System (canal and pipeline) provides the additional plumbing to the California Aqueduct necessary to increase the rate of delivery of surface water supplies and return of previously-banked water.

In-Lieu Distribution System- The In-Lieu Distribution System provides additional groundwater recharge capacity through the in-lieu banking feature and by increasing recovery capacity. Proceeding from south to north, the three distribution systems are referred to as "X," "Y," and "Z." Each system is designed to deliver surface water (when available) to lands otherwise reliant on pumped groundwater for irrigation. The North-South Conveyance System provides for the delivery of water to and from the California Aqueduct and the In Lieu System Area (ILSA). The pipeline laterals which deliver water to the ILSA would also provide the means by which stored water would be recovered and delivered from the ILSA to the North-South Conveyance System when the wells are being used to recover previously-banked water. Farm turnouts provide the interface between the District's system and the landowner's system and include provision for the metering of flows (both instantaneous rate and cumulative volume).

Well Field- Up to 65 high production wells and a network of pipelines provide the means for recovery of previously-banked water. Stored water recovered by the Well Field would be conveyed via collector pipelines to a regulating reservoir, then pumped into a pipeline/canal (North-South Conveyance System) by a proposed pumping plant (the Regulation Reservoir Pumping Plant) located adjacent to the Regulation Reservoir. The Regulation Reservoir would serve to balance the flow of water delivered from the wells and

pumped into the North-South Conveyance System.

Regulation Reservoir-The Regulation Reservoir is proposed to be constructed immediately east of the North-South Conveyance System and adjacent to the proposed well field. Its function is to regulate water produced in the well field and provide a pool from which to pump water into the North-South Conveyance System. The Regulation Reservoir Pumping Plant is proposed to be located adjacent to the southern portion of the Regulation Reservoir. Its main function is to pump water out of the Regulation Reservoir and into the North-South Conveyance System for ultimate delivery into the California Aqueduct.

Regulation Reservoir / Poso Creek Overpour- the Regulation Reservoir / Poso Creek Overpour, or spillway, is a concrete weir structure that is proposed to be located on the southern levee of Poso Creek adjacent to the Regulation Reservoir to allow diversion into and out of the Poso Creek Flood Channel. The weir structure would allow the District to divert wet-year water from Poso Creek into the Regulation Reservoir, which would be subsequently pumped into the North-South Conveyance System. This creek-side facility would also allow the District to convey regulated water to the Kern NWR. During flood events on Poso Creek, the weir structure could take 300 cfs of the occurring flood flows, thereby reducing flood damage within the Kern NWR and adjacent agriculture lands.

Poso Creek Control Structure- The Poso Creek Control Structure is a control structure that would be operated in conjunction with the Regulation Reservoir / Poso Creek Overpour. In a wet-year period, when flood waters are occurring in Poso Creek, the Poso Creek Control Structure would allow the District to raise the water surface elevation in Poso Creek to allow for diversion of flows into the Regulation Reservoir via the Regulation Reservoir / Poso Creek Overpour. The diverted water would be subsequently pumped into the North-South Conveyance System for capture and delivery to the District.

A 27" Kern NWR Supply Pipeline would supply water to the Kern NWR. This pipeline is approximately 3,000 feet long and will provide a connection between the North-South Conveyance System and the Well Field. It will allow for water to be delivered from within various sources within the District to the Refuge.

**If applicable, list surface water bodies and groundwater basins associated with the proposed project:**

<ul style="list-style-type: none"><li>• Surface water delivered via CA Aqueduct or Friant-Kern Canal</li></ul>
<ul style="list-style-type: none"><li>• Pond Poso Canal</li></ul>
<ul style="list-style-type: none"><li>• Poso Creek Flood Channel</li></ul>
<ul style="list-style-type: none"><li>• Kern Groundwater Basin</li></ul>

**Please identify up to three available documents which contain information specific to the proposed project. Include conceptual plans, permits, drawings, and technical documents:**

<ul style="list-style-type: none"><li>• Supplemental and Final Environmental Impact Report</li></ul>
<ul style="list-style-type: none"><li>•</li></ul>
<ul style="list-style-type: none"><li>•</li></ul>

**Please identify federal, state, or local permits, which pertain to the proposed project and would need to be obtained or, if existing, would need to be amended:**

<ul style="list-style-type: none"><li>• Federal: US Fish and Wildlife Service</li></ul>
<ul style="list-style-type: none"><li>• State: DFG, DoT, RWQCB, etc.</li></ul>
<ul style="list-style-type: none"><li>• Local: SJV Unified Air Pollution Control District, Kern County, SWPPP-NOI, Encroachment, etc.</li></ul>

Please identify any existing projects or facilities, including existing water conveyance infrastructure, which would be affected, modified, or superseded as a result of implementing the proposed project:

• California Aqueduct
• Pond Poso Canal
• Poso Creek Flood Channel

Is the proposed project an element or phase of a regional or larger program?	<input checked="" type="checkbox"/> Yes <input type="checkbox"/> No
If yes, please identify the program:	<u>Poso Creek IRWMP</u>
Design life of the project:	<u>50</u>
Proposed Construction/Implementation Start Date:	<u>Yet Unknown</u>
Proposed Construction/Implementation Completion Date:	<u>Yet Unknown</u>
Ready for Construction Bid:	<input type="checkbox"/> Yes <input checked="" type="checkbox"/> No <input type="checkbox"/> N/A

Item	Status (e.g., not initiated, in process, complete)	Date (mm/dd/yyyy)
Conceptual Plans	<b>Complete</b>	09/1/1999
Land Acquisition/ Easements	<b>In Process</b>	
Preliminary Plans	<b>In Process</b>	
CEQA/NEPA	<b>CEQA is Complete; NEPA would be required if a federal nexus exists (i.e. through federal grant funding for example).</b>	09/1/1999
Permits	<b>In Process</b>	
Construction Drawings	<b>Preliminary, In Process</b>	

For projects ready for construction or implementation, including projects which do not include construction, briefly describe the project's readiness to proceed.

**Project Readiness (Narrative)**

Portions of the Project are “shovel ready” inasmuch as Issued for Construction drawings have been prepared and all required regulatory permits have been obtained, with the exception of construction-related permits, which would be acquired at the onset of the Project. Components that would be ready to construct include the North-South Conveyance System and the In-Lieu portion of the SWRU, Systems X. A detailed cost estimate has been provided and is available to support construction documents. Funding requires over a minimum of \$30M for the next phase of this project to realize the benefits. Preliminary/conceptual drawings for other components of the Project have been prepared and would require the reparation of final drawings, acquisition of easements/fee parcels and the acquisition of construction-related permits to commence work.

Include any local or state board actions, code changes, or legislation needed in order to proceed with the project.

**Local or State Board Actions, Code Changes, or Legislation**

SWSD Board of Directors would need to authorize funding for the project to proceed.

**Please describe the dominant existing land use type for the proposed project location.**

Agricultural, with some private property occurring sporadically throughout the area.

**Please describe the dominant existing land use type for areas upstream and downstream of the proposed project location**

Upstream:	See above
Downstream:	Agriculture is served by CA Aqueduct and the Kern National Wildlife Refuge is downstream from this area along the Poso Creek Flood Channel.

## Part 4. Project Benefits

Please provide a one or two paragraph description of the benefit(s) that the project will address. Benefit Categories, shown below, are referenced from the [Storm Water Resource Plan Guidelines](#), Page 31, Table 4. Each project should address at least two or more Main Benefits and as many Additional Benefits as feasible. Information you provide will be used to evaluate the project for State grant funding.

Storm Water Management Benefits		
Benefit Category	Main Benefit	Additional Benefit
<b>Water Quality</b> (while contributing to compliance with applicable permit and/or TMDL requirements)	<ul style="list-style-type: none"> <li>Increased filtration and/or treatment of run-off</li> <li>Potential improvements in groundwater quality</li> </ul>	<ul style="list-style-type: none"> <li>Non-point source pollution control</li> <li>Reestablished natural water drainage and treatment</li> </ul>
<b>Water Supply</b> (through groundwater management and/or run-off capture and use)	<ul style="list-style-type: none"> <li><b>Water supply reliability</b></li> <li><b>Expand Conjunctive use</b></li> <li><b>Reduce short-term groundwater level declines</b></li> </ul>	<ul style="list-style-type: none"> <li>Water conservation</li> </ul>
<b>Flood Management</b>	<ul style="list-style-type: none"> <li>Decreased flood risk by reducing run-off rate and/or volume</li> <li>Flood reduction benefits</li> </ul>	<ul style="list-style-type: none"> <li>Reduced sanitary sewer overflows</li> </ul>
<b>Environmental and Habitat Enhancement</b>	<ul style="list-style-type: none"> <li>Environmental and habitat protection and improvement, including;                             <ul style="list-style-type: none"> <li>wetland enhancement/creation;</li> <li>riparian enhancement; and/or</li> <li>instream flow improvement</li> </ul> </li> <li>Increased urban green space</li> </ul>	<ul style="list-style-type: none"> <li>Reduced energy use, greenhouse gas emissions, or provides a carbon sink</li> <li>Reestablishment of the natural hydrograph</li> <li>Water temperature improvements</li> </ul>
<b>Community Stewardship</b>	<ul style="list-style-type: none"> <li>Employment opportunities provided</li> <li>Public Education</li> </ul>	<ul style="list-style-type: none"> <li>Community involvement</li> <li>Enhance and/or create recreational and public use areas</li> </ul>

Source: Page 31, Table 4, Storm Water Resource Plan Guidelines, State Water Resources Control Board

Please provide the following **PROJECT BENEFIT** information for all applicable components of the proposed project. Benefit categories include:

- **Water Supply**
- **Flood Management**
- **Environmental and Habitat Enhancement**
- **Community Stewardship**

If the project benefits a disadvantaged community (DAC) describe the specific benefits to that community. Estimate the percentage of the project benefits to the DAC.

Please supply all information relevant to the proposed project. The information you provide will be used to evaluate the project for State grant funding. **Attach additional sheets if necessary.**

## Water Quality Benefits

1. Describe how the proposed project will improve source control for both pollution and dry weather runoff volume, onsite and local infiltration, and use of storm water and dry weather runoff.
2. Describe design criteria and best management practices to prevent storm water and dry weather runoff pollution and increase effective storm water and dry weather runoff management for new and upgraded infrastructure and residential, commercial, industrial, and public development
3. Describe how the proposed project complies with or is consistent with an applicable NPDES permit. The analysis should simulate the proposed watershed-based outcomes using modeling, calculations, pollutant mass balances, water volume balances, and/or other methods of analysis. Describe how the proposed project will contribute to the preservation, restoration, or enhancement of watershed processes (as described in Guidelines section VI.C.2.a)
4. Describe the water quality monitoring and data acquisition that will be implemented in conjunction with the proposed project. Describe the a) mechanisms by which data will be managed and stored; b) how data will be accessed by stakeholders and the public; c) how existing water quality and water quality monitoring will be assessed; d) frequency at which data will be updated; and e) how data gaps will be identified.

### Water Quality Benefits (Narrative)

<p>This project also has the potential to improve water quality as follows:</p> <ul style="list-style-type: none"> <li>• Enhancement of groundwater quality due to decreased pumping lifts and stabilization of the water table, which reduces the chances of water quality changing due to pumping from zones of less quality; and</li> <li>• Enhancements to water quality due to the importation of surface water to the District in wet years, which delivers surface water of quality suitable for the beneficial uses within the region.</li> </ul>	
Pollutant TMDL reduction (Volume per day) and (mass /unit volume) of most probable number of bacteria or indicator organisms (mpn/mL):	<u>N/A</u>
Increase in infiltration rate above existing condition:	<u>The Project increases the ability to absorb surface water supply since it connects the District's distribution system with 12,000 acres previously only served by groundwater.</u>
Non-point source pollution control:	<u>N/A</u>
Does project affect an Existing NPDES Permit? If applicable, describe the need for a new NPDES Permit:	<u>N/A</u>

## Water Supply Benefits

1. Describe how the proposed project captures and reuses storm water and dry weather runoff for groundwater recharge or storage for beneficial use.
2. Please provide detailed information to quantify how the proposed project will reduce existing potable water demand.
3. Describe the water supply monitoring and data acquisition that will be implemented in conjunction with the proposed project. Describe the a) mechanisms by which data will be managed and stored; b) how data will be accessed by stakeholders and the public; c) how existing water quality and water quality monitoring will be assessed; d) frequency at which data will be updated; and e) how data gaps will be identified

### Water Supply Benefits (Narrative)

The put and take operation of the current Semitropic Groundwater Bank is limited by the availability of surface supplies, capacity of the existing intake, conveyance, and pump back facilities, and the ability to deliver (absorb) surface water using the lateral distribution and irrigation systems. With the proposed construction of a conveyance pipeline originating at the Pond-Poso Canal, an opportunity is created to significantly enhance the put, which is the absorptive capacity of the Groundwater Bank. This additional capacity, coupled with a balancing reservoir adjacent to the Pond-Poso Canal, could greatly enhance the operational flexibility of the put operation and increase the absorptive capacity of the in-lieu portion of the Bank. Ongoing water supply monitoring and data acquisition is done by the Semitropic Staff and communicated to the neighboring districts through the Semitropic Groundwater Monitoring Committee. The committee acquires and stores hydrology data collected by the District Staff, the Kern County Water Agency, and the DWR's CA Aqueduct operators.

### Enhanced Water Supply or Demand Reduction Benefit Information

<b>Source of Increased Supply or Demand Reduction</b>	
<input checked="" type="checkbox"/> Groundwater	<input type="checkbox"/> Groundwater treatment
<input type="checkbox"/> Recycled water	<input checked="" type="checkbox"/> Conservation/ water use efficiency
<input type="checkbox"/> Transfer	<input type="checkbox"/> Other (describe):
<input checked="" type="checkbox"/> Increased surface water storage	<input type="checkbox"/> Ocean desalination
Type of enhanced supply or demand reduction:	Groundwater; in-lieu recharge.
Annual Yield of Supply (acre-feet):	12,600 AF
<b>Availability by Water-Year Type (acre-feet per year)</b>	
Average Year:	<u>0.3 times 42,000 AFY = 12,600 AF</u>
Dry Year:	<u>Return of Previously Stored Water</u>
Wet Year:	<u>12,000 Acres x 3.5 AF/A delivery = 42,000 AFY</u>
<b>Availability by Season (check all that apply):</b>	
<input checked="" type="checkbox"/> Summer	<input checked="" type="checkbox"/> Fall
<input checked="" type="checkbox"/> Spring	<input checked="" type="checkbox"/> Winter
<b>Does the project have the potential to displace demands on the Bay/Delta/Estuary?</b>	
<input checked="" type="checkbox"/> Yes	<input type="checkbox"/> No
<input type="checkbox"/> Not Sure	



## Flood Management Benefits

1. Describe how the proposed project will reestablish natural water drainage treatment and infiltration systems, or mimic natural system functions to the maximum extent feasible.
2. Describe how the proposed project will reduce flood risk by reducing runoff rate and/or volume.
3. If applicable, describe how the proposed project will reduce the risk of sanitary sewer overflows.

### Flood Management Benefits (Narrative)

<p>The Project provides a flood management benefit inasmuch as the water stored will not contribute to increased downstream flows and flood risks from where the water is diverted. In the case of Semitropic's Water Bank, flood flow is delivered via the CA Aqueduct into the SWRU conveyance system, therefore, the added absorptive capacity enhances the CA Aqueduct in reducing flood risk by allowing diversions into the CA Aqueduct, upstream of the Semitropic turnout.</p> <p>Additionally, the Project also provides for a flood management benefit with the construction of an overpour structure, control structure and regulating reservoir off of the Poso Creek Flood Channel. The facilities would allow the District to divert wet-year water from Poso Creek into the Regulation Reservoir, which would be subsequently pumped into the North-South Conveyance System. This creek-side facility would also allow the District to convey regulated water to the Kern NWR. During flood events on Poso Creek, the weir structure could take 300 cfs of the occurring flood flows, thereby reducing flood damage within the Kern NWR and adjacent valuable agriculture lands.</p>	
Maximum volume of temporary storage of storm water runoff (acre-feet):	<p>Since Stormwater is more likely to occur in early spring and late fall part of the growing season, called the shoulder months, an estimate of 20 percent of the total absorptive capacity, 8,400 AF of in-lieu recharge is available during this time.</p> <p>[0.20 * 42,000 AF = 8,400 AF]</p>
Maximum increased conveyance capacity (cubic feet/second):	300
Estimated area benefiting from flood damage reduction (acres):	Unknown, qualitatively estimated to be all agricultural lands adjacent to the Poso Creek Flood Channel and the Kern NWR, which have historically been flooded during major flooding events.
Estimated level of flood protection resulting from project implementation (% annual probability of recurrence or 1-in-number of years recurrence):	Unknown
Estimated annual value of flood damage reduction provided by project (\$/year):	Unknown
Land required for project implementation (acres):	40-80

### For projects that include detention and groundwater recharge, please complete the following:

How many acres of land drain into this detention basin? (acres):	Unknown; surface water is diverted into the CA Aqueduct which delivers to Semitropic WSD.
Detention Basin area (acres):	N/A

Detention basin max. operational depth (ft.):	N/A
% of basin covered by wetlands:	0
Soil type:	Loam
If other than infiltration, identify method (e.g., injection) and recharge (acre-feet/year):	In-lieu recharge; The projects recharge is predicated on in-lieu recharge whereby for every 1 af of surface water delivered, 1 af of water of pumping is displaced.
Estimated basin annual inflow (acre-feet/year):	N/A
Estimated basin annual outflow (acre-feet/year):	N/A

## Environmental and Habitat Enhancement Benefits

Describe how the proposed project identifies opportunities to develop, restore, or enhance habitat and open space through storm water and dry weather runoff management, including wetlands, riverside habitats, parkways, and parks. Provide some type of quantitative measurement, which will show how the project benefits the environment and enhances the natural habitat.

### Environmental and Habitat Enhancement Benefits (Narrative)

A component of the Project, construction of the Regulation Reservoir, has the potential for developing and enhancing habitat and open space as described below. The reservoir will be located adjacent to and south of the Poso Creek Flood Channel within a larger parcel that will be used to regulate water diverted from Poso Creek from time to time and could ultimately be developed into a managed wetlands area. The current configuration of the reservoir is a “dumbbell” shape with the easterly levees curved and the exterior slopes flattened to enhance duck club aesthetics to accommodate an existing active duck club pond that is adjacent to and east of the reservoir. The configuration of the reservoir was coordinated with the adjacent duck club owner for this reason. Once constructed, the Regulation Reservoir, has the potential to provide a habitat for various birds and waterfowl that also provides an opportunity for the public to view the waterfowl.

Non-treatment wetland area (acres):	<u>Up to 40 acres</u>
Treatment wetland area (acres):	<u>N/A</u>
Riparian habitat area (acres):	<u>N/A</u>
Non-developed open space area (acres):	<u>N/A</u>
Total Project area (acres):	<u>Up to 40 acres</u>

## Community Stewardship Benefits

Describe how the project identifies opportunities to use existing publicly owned lands and easements, including, but not limited to parks, open space, community gardens, farm and agricultural preserves, school sites, and government office buildings and complexes, to capture, clean, store, and use storm water and dry weather runoff either onsite or offsite. Provide some type of quantitative measurement, which will show how the project benefits the community.

### Community Stewardship Benefits (Narrative)

<p>A component of the Project, construction of the Regulation Reservoir has the potential for providing project benefits to the community as described below. As described above, once constructed, the Regulation Reservoir, has the potential to provide a habitat for various birds and waterfowl that also provides an opportunity for the public to view the waterfowl.</p>
--

**Multiple use/ recreation area (acres) – additionally, select the type of multiple use / recreation and associated acres by type:**

Single Sport Athletics:	<u>N/A</u>
Multiple Sport Athletics Acres:	<u>N/A</u>
Other Recreation Acres:	<u>N/A</u>
Pedestrian Trail Acres:	<u>N/A</u>
Equestrian Trail Acres:	<u>N/A</u>
Other Passive Activity:	<u>Bird viewing</u>
Other Acres (describe):	<u>N/A</u>
Description:	<u>N/A</u>
<b>Total Project Area (acres):</b>	<u>40-60 acres (Regulation Reservoir)</u>

## Part 5. Project Cost Estimate

Project cost information is needed to assist in comparing benefits and cost. Additionally, knowledge of the project type and cost will assist in identifying funding sources for potential projects.

Please indicate the estimated costs of project implementation and associated funding source(s). These costs should include land purchase/easement, planning/design/engineering, construction/ implementation, environmental compliance, administration, and contingency.

<p><b>Approximate Total Cost:</b> (If project costs are variable, please include lower and upper range estimates.)</p>	Approximately \$100,000,000.00+
<p><b>Funding Source:</b> (If multiple sources, list each source and the percent or amount funded by each)</p>	<ul style="list-style-type: none"> <li>• Potential future grant funding;</li> <li>• Banking Partners;</li> <li>• District Assessments</li> </ul>
<p><b>Maximum Funding Match from Implementing Agency:</b></p>	N/A
<p><b>Funding Certainty &amp; Longevity:</b></p>	Unknown
<p><b>Operations &amp; Maintenance Cost:</b> (per year)</p>	Unknown
<p><b>Operations &amp; Maintenance Funding Source(s)</b> (i.e., annual budget, grant, etc. If multiple sources, list each source and the percent or amount funded by each.)</p>	Annual Budget
<p><b>Operations &amp; Maintenance Funding Certainty:</b> (i.e., already included in organization's budget, contingent upon grant, etc.)</p>	Included as part of setting of annual budget

# Kern Storm Water Resource Plan

## Project Submittal Form

This form is to be electronically filled out and e-mailed to [LMarino@ppeng.com](mailto:LMarino@ppeng.com) by June 24, 2016.

Reference: [Storm Water Resource Plan Guidelines](#), December 15, 2015  
State Water Resources Control Board

### Part 1. Lead Implementing Agency/Organizational Information

Please provide the following information regarding the project sponsor and proposed project.

**Implementing Agency / Organization / Individual:**

Semitropic Water Storage District

**Agency / Organization / Individual Address:**

1101 Central Ave, Wasco, CA 93280

**Possible Partnering Agencies:**

**Name:**

Jason Gianquinto

**Title:**

General Manager

**Telephone:**

661-758-5113

**Fax:**

661-758-3219

**Email:**

[mail@semitropic.com](mailto:mail@semitropic.com)

**Website:**

[www.semitropic.com](http://www.semitropic.com)

**Project Name:**

Entrance Ponds to the Pond Poso Spreading Grounds

Either the latitude/longitude or a location description is required. To determine the latitude/longitude, use the closest address or intersection. If the project is linear, use the furthest upstream latitude/longitude.

**Project Latitude:**  **Project Longitude:**

<b>Location Description:</b>	The Project is 7 miles northwest of Wasco, northeast and adjacent to the existing Pond-Poso Spreading Grounds, located in Section 9, Township 26 South, Range 24 East, MDB&M.
------------------------------	---

**Project Cooperating Agency(ies)/Organization(s)/Individual(s):**

- |  |
|--|
| <ul style="list-style-type: none"><li>• Potentially Banking Partners</li></ul> |
| <ul style="list-style-type: none"><li>• Neighboring Water Districts</li></ul>  |
| <ul style="list-style-type: none"><li>• Other Interested Parties</li></ul>     |
|  |

**Project Status (e.g., new, ongoing, expansion, new phase):**

**Has the Project been submitted to IRWM Plan:**

Kern IRWMP  Poso Creek IRWMP  Not Submitted

**Does the project address any known environmental justice issues?**

Yes  No  Not Sure

**Is the project located within or adjacent to a disadvantaged community (DAC)? Refer to this [website](#).**

Within  Adjacent  No  Not Sure

**Does the project include DAC participation?**

Yes  No  Not Sure

If yes, please identify the contact person, group, or organization and describe the DAC's participation:

**What is the DAC's estimated population?**

Does the Implementing Agency own the land where the project is located? If no, describe ability to purchase land or if eminent domain is required:

Yes  No

## Part 2. Project Need

It is important to understand the need(s) or issue(s) that the proposed project will address and the benefits that it will provide. Information provided in this section defines the need(s) or issue(s) that the proposed project will address and will help to catalog existing need(s) or issue(s) in the planning area of the Kern Storm Water Resource Plan.

Please provide a 1-2 paragraph description of the need(s) or problem(s) that the proposed project will address. Discuss the benefits to water quality, water supply, flood management, environmental, and community benefits that the proposed project will bring. Discuss critical impacts or worsening conditions that will occur if the proposed project is not implemented.

### Project Need (Narrative)

The Entry Ponds to the Pond Poso Spreading Grounds (PPSG) (the Project) is a component of the Semitropic Groundwater Bank and will enhance the operation of the Bank. The Project, will allow the District to divert floodwater/stormwater and to drop out sediment contained in stormwater during high-flow events originating from the Poso Creek Flood Channel. In this regard, it will provide the District the ability to convey and manage floodwater originating from the Poso Creek Flood Channel, which absent the Project, would be delivered as uncontrolled floodwater to the Kern NWR and adjacent agricultural lands.

The Project is an expansion of the District's recharge and extraction facility, the PPSG, that once fully completed, will allow for the diversion of up to 350 cubic feet per second (cfs) of occurring flood flows during a wet period or opportunistic time to bank water supplies. The yield is equivalent to 700 acre-feet per day or 7,000 acre-feet for a 10-day storm event. In this regard, the Project has a potential to place up to 21,000 acre-feet of water into storage in a given one month period.

The Project will also provide for flood management benefits inasmuch as it will accommodate diversion of flood flows from the Poso Creek Flood Channel, through the Poso Creek diversion works structure, which conveys water from Poso Creek into the Entrance Ponds to the PPSG and ultimately into the District's system.

The primary purpose of the Project is to improve the sustainability of the local water supplies and conjunctively manage the surface and groundwater resource for the benefit of the area. The need results from a number of actions which have served to reduce the historical reliability of water supplies available to the region. The secondary objective of the project is to provide flood management benefits. The need arises from a number of historical hydrological events which have caused significant damages to adjacent valuable agricultural lands and facilities.



### Part 3. Project Description

A general description of the proposed project is needed. This section will provide information associated with the project concept and general project information. Much of the requested information may not be available for projects that are in the conceptual stages of development. An essential element of the Kern Storm Water Resource Plan consists of proposed projects. We appreciate and need your ideas.

Please provide a one or two paragraph description of the project including the general project concept, what will be constructed/implemented, how the constructed project will function, what technologies or methods will be used, as appropriate. For water quality projects, include a description of impacts to existing Total Maximum Daily Loads, NPDES permits, and/or waste discharge requirements.

#### Project Description (Narrative)

<p>The Project consists of the following facilities:</p> <p>Development of 320 gross acres into diked ponds (240 acres north and 80 acres south of Poso Creek), with up to 10 “cells” and a serpentine design to allow sediment to drop off before it is diverted to the District’s PPSG and/or the Pond Poso Canal;</p> <p>Construction of a reinforced concrete diversion works structure located on the Poso Creek channel with two adjustable weirs, two fixed weirs, and a 200-foot wide earthen weir with a capacity of diverting up to 350 cfs of floodwater/stormwater from Poso Creek into the diked ponds;</p> <p>Construction of up to eight (8) overpour structures to convey water to the lower elevation diked ponds;</p> <p>Construction of an outlet structure located on the lowest tiers of the diked ponds, adjacent to the Pond Poso Canal to divert water into the District’s canal once all of the sediment has been dropped out;</p> <p>Construction of two outlet structures located on the lowest tiers of the diked ponds adjacent to the Poso Creek Flood Channel to overflow water into the creek in the event the inflow into the diked ponds exceeds the ponds capacity;</p> <p>Construction of a low-head pumping plant (100 cfs), with 80 linear feet of 48-inch steel manifold pipe, and up to 600 linear feet 60-inch RCP pipe with a 120-inch riser on the lower tier of the diked ponds south of Poso Creek to facilitate lifting of water into the PPSG recharge ponds for recharge and storage; and</p> <p>Construction of up to six (6) high production wells and a network of pipelines and appurtenances to recover water that has been previously recharged.</p> <p>During “put” operations, surface water originating from floodwater/stormwater would be diverted and captured from Poso Creek, diverted to the diked ponds for settlement of sediment, then conveyed into the District’s Pond Poso Canal and/or the PPSG for recharge and storage.</p>
---

#### If applicable, list surface water bodies and groundwater basins associated with the proposed project:

<ul style="list-style-type: none"><li>• Poso Creek Flood Channel</li></ul>
<ul style="list-style-type: none"><li>• Pond Poso Canal</li></ul>
<ul style="list-style-type: none"><li>• Kern Groundwater Basin</li></ul>
<ul style="list-style-type: none"><li>•</li></ul>

Please identify up to three available documents which contain information specific to the proposed project. Include conceptual plans, permits, drawings, and technical documents:

• 2010 WaterSMART Pond Poso Retention Ponds – Phase II Grant Application
• CEQA Document (IS/ND) Prepared in 2007
•

Please identify federal, state, or local permits, which pertain to the proposed project and would need to be obtained or, if existing, would need to be amended:

• Update CEQA for GHG Emissions
• State: Dept. of Fish & Game
• Local: SJV Unified Air Pollution Control District, SWPPP NOI

Please identify any existing projects or facilities, including existing water conveyance infrastructure, which would be affected, modified, or superseded as a result of implementing the proposed project:

• Expansion of the Pond Poso Spreading Grounds
• Pond Poso Canal
• Poso Creek Flood Channel

Is the proposed project an element or phase of a regional or larger program?:	<input checked="" type="checkbox"/> Yes <input type="checkbox"/> No
If yes, please identify the program:	<u>Poso Creek IRWMP</u>
Design life of the project:	<u>50</u>
Proposed Construction/Implementation Start Date:	<u>Yet Unknown</u>
Proposed Construction/Implementation Completion Date:	<u>Yet Unknown</u>
Ready for Construction Bid:	<input type="checkbox"/> Yes <input checked="" type="checkbox"/> No <input type="checkbox"/> N/A

Item	Status (e.g., not initiated, in process, complete)	Date (mm/dd/yyyy)
Conceptual Plans	<b>Complete</b>	04/11/2012
Land Acquisition/ Easements	<b>Complete</b>	
Preliminary Plans	<b>Complete</b>	04/11/2012
CEQA/NEPA	<b>CEQA completed in 2007; update for GHG may be needed. NEPA would be required if a federal nexus exists.</b>	
Permits	<b>Not Initiated</b>	
Construction Drawings	<b>Preliminary drawings have been prepared.</b>	

For projects ready for construction or implementation, including projects which do not include construction, briefly describe the project's readiness to proceed.

**Project Readiness (Narrative)**

With the exception of the potential acquisition of regulatory permits, the Project is "shovel ready" inasmuch as Issued for Construction Drawings are substantially completed, at the 60-percent level, the land is owned in fee and construction-related permits would be secured in a timely manner. Additionally, the Project is covered under the CEQA IS/ND, which was completed in 2007.

Include any local or state board actions, code changes, or legislation needed in order to proceed with the project.

**Local or State Board Actions, Code Changes, or Legislation**

The Project can be implemented by Board action.

**Please describe the dominant existing land use type for the proposed project location.**

**Agricultural**

**Please describe the dominant existing land use type for areas upstream and downstream of the proposed project location**

Upstream:	Agricultural
Downstream:	Agricultural/Spreading Grounds

## Part 4. Project Benefits

Please provide a one or two paragraph description of the benefit(s) that the project will address. Benefit Categories, shown below, are referenced from the [Storm Water Resource Plan Guidelines](#), Page 31, Table 4. Each project should address at least two or more Main Benefits and as many Additional Benefits as feasible. Information you provide will be used to evaluate the project for State grant funding.

Storm Water Management Benefits		
Benefit Category	Main Benefit	Additional Benefit
<b>Water Quality</b> (while contributing to compliance with applicable permit and/or TMDL requirements)	<ul style="list-style-type: none"> <li>Increased filtration and/or treatment of run-off</li> <li>Potential improvements in groundwater quality</li> </ul>	<ul style="list-style-type: none"> <li>Non-point source pollution control</li> <li>Reestablished natural water drainage and treatment</li> </ul>
<b>Water Supply</b> (through groundwater management and/or run-off capture and use)	<ul style="list-style-type: none"> <li><b>Water supply reliability</b></li> <li><b>Expand Conjunctive use</b></li> <li>Reduce short-term groundwater level declines</li> </ul>	<ul style="list-style-type: none"> <li>Water conservation</li> </ul>
<b>Flood Management</b>	<ul style="list-style-type: none"> <li><b>Decreased flood risk by reducing run-off rate and/or volume</b></li> </ul>	<ul style="list-style-type: none"> <li>Reduced sanitary sewer overflows</li> </ul>
<b>Environmental and Habitat Enhancement</b>	<ul style="list-style-type: none"> <li>Environmental and habitat protection and improvement, including;                             <ul style="list-style-type: none"> <li>wetland enhancement/creation;</li> <li>riparian enhancement; and/or</li> <li>instream flow improvement</li> </ul> </li> <li>Increased urban green space</li> </ul>	<ul style="list-style-type: none"> <li>Reduced energy use, greenhouse gas emissions, or provides a carbon sink</li> <li>Reestablishment of the natural hydrograph</li> <li>Water temperature improvements</li> </ul>
<b>Community Stewardship</b>	<ul style="list-style-type: none"> <li>Employment opportunities provided</li> <li>Public Education</li> </ul>	<ul style="list-style-type: none"> <li>Community involvement</li> <li>Enhance and/or create recreational and public use areas</li> </ul>

Source: Page 31, Table 4, Storm Water Resource Plan Guidelines, State Water Resources Control Board

Please provide the following **PROJECT BENEFIT** information for all applicable components of the proposed project. Benefit categories include:

- **Water Quality**
- **Water Supply**
- **Flood Management**
- **Environmental and Habitat Enhancement**
- **Community Stewardship**

If the project benefits a disadvantaged community (DAC) describe the specific benefits to that community. Estimate the percentage of the project benefits to the DAC.

Please supply all information relevant to the proposed project. The information you provide will be used to evaluate the project for State grant funding. **Attach additional sheets if necessary.**

## Water Quality Benefits

1. Describe how the proposed project will improve source control for both pollution and dry weather runoff volume, onsite and local infiltration, and use of storm water and dry weather runoff.
2. Describe design criteria and best management practices to prevent storm water and dry weather runoff pollution and increase effective storm water and dry weather runoff management for new and upgraded infrastructure and residential, commercial, industrial, and public development
3. Describe how the proposed project complies with or is consistent with an applicable NPDES permit. The analysis should simulate the proposed watershed-based outcomes using modeling, calculations, pollutant mass balances, water volume balances, and/or other methods of analysis. Describe how the proposed project will contribute to the preservation, restoration, or enhancement of watershed processes (as described in Guidelines section VI.C.2.a)
4. Describe the water quality monitoring and data acquisition that will be implemented in conjunction with the proposed project. Describe the a) mechanisms by which data will be managed and stored; b) how data will be accessed by stakeholders and the public; c) how existing water quality and water quality monitoring will be assessed; d) frequency at which data will be updated; and e) how data gaps will be identified.

### Water Quality Benefits (Narrative)

<p>The Project will improve the quality of water by allowing for the removal of sediment prior to diverting the water to the District's Pond Poso Canal and/or the Pond Poso Spreading Grounds. In doing so it will also improve the effectiveness of the aquifer, recharge operation within the Pond Poso Spreading Grounds by decreasing the amount of silt that reaches the recharge ponds, maintaining recharge rates, and increasing total water supply benefit.</p> <p>It is recognized in the Poso Creek IRWMP area that the majority of recharge facilities are constructed and operated by the agricultural districts and not by the small disadvantaged communities or the environmental water users, this project also has the potential to improve water quality as follows:</p> <ul style="list-style-type: none"> <li>• Enhancement of groundwater quality due to decreased pumping lifts and stabilization of the water table, which reduces the chances of water quality changing due to pumping from zones of less quality; and</li> <li>• Enhancements to water quality due to the importation of surface water to the District in wet years, which delivers surface water of quality suitable for the beneficial uses within the region.</li> </ul>	
Pollutant TMDL reduction (Volume per day) and (mass /unit volume) of most probable number of bacteria or indicator organisms (mpn/mL):	<u>Unknown</u>
Increase in infiltration rate above existing condition:	<u>The Project connects floodwater/storm water to recharge basins</u>
Non-point source pollution control:	<u>Unknown</u>
Does project affect an Existing NPDES Permit? If applicable, describe the need for a new NPDES Permit:	<u>Unknown</u>

## Water Supply Benefits

1. Describe how the proposed project captures and reuses storm water and dry weather runoff for groundwater recharge or storage for beneficial use.
2. Please provide detailed information to quantify how the proposed project will reduce existing potable water demand.
3. Describe the water supply monitoring and data acquisition that will be implemented in conjunction with the proposed project. Describe the a) mechanisms by which data will be managed and stored; b) how data will be accessed by stakeholders and the public; c) how existing water quality and water quality monitoring will be assessed; d) frequency at which data will be updated; and e) how data gaps will be identified

### Water Supply Benefits (Narrative)

<p>The Project, once fully developed, will provide the following estimated water supply benefits:</p> <p>1) An estimated quantifiable water savings of 1,120 acre-feet per year based on the conversion of agricultural land to retention ponds (the estimated water savings per year is based on 320 gross acres of cropland with an applied water use of 3.5 acre-feet per year being converted to non-cropland);</p> <p>2) An additional 160 acre-feet per day capacity for aquifer recharge when the area is wet and in use as retention ponds (estimated rate of recharge is at minimum 0.5 acre-feet per day); and,</p> <p>3) Added flexibility for regional water management by adding a 350 cfs conveyance route from Poso Creek Flood Channel to the District's spreading facility and/or Pond Poso Canal for local surface water and CVP water supplies (equivalent volumes for the added route capacity of 350 cfs are 700 acre-feet per day or 21,000 acre-feet per month).</p>
---

### Enhanced Water Supply or Demand Reduction Benefit Information

<b>Source of Increased Supply or Demand Reduction</b>	
<input checked="" type="checkbox"/> Groundwater <input type="checkbox"/> Recycled water <input type="checkbox"/> Transfer	<input type="checkbox"/> Groundwater treatment <input checked="" type="checkbox"/> Conservation/ water use efficiency <input type="checkbox"/> Other (describe):
<input checked="" type="checkbox"/> Increased surface water storage <input type="checkbox"/> Ocean desalination	
Type of enhanced supply or demand reduction:	Recharged groundwater
Annual Yield of Supply (acre-feet):	1,280 AFY = 1,120 AFY Conserved Water plus (320 AFY) 160 AF per Day for 10 days, twice in 10 years [160 * 10 * 2 / 10]; this is a component of the PPSGs diverting 350 cfs per day, 7,000AF per flood event (for a single flooding event over a period of 10 days)
<b>Availability by Water-Year Type (acre-feet per year)</b>	
Average Year:	[1,280 AFY = 1,120 AFY plus 320 AFY] [320 AFY = 160 AF/D * 10 Days/Y * (2 wet years / 10 years)]
Dry Year:	<u>1,120 AFY</u>
Wet Year:	<u>AF = 1,120 AFY plus 1,600 [160 AF/D times 10 days]; the PPSGs facility has the ability to absorb 7,000AF during a wet period event [700AF/D times 10 days] in addition to the area specific to the Entrance Ponds component of the PPSGs.</u>
<b>Availability by Season (check all that apply):</b>	

<input checked="" type="checkbox"/> Summer	<input checked="" type="checkbox"/> Fall	<input checked="" type="checkbox"/> Spring	<input checked="" type="checkbox"/> Winter
<b>Does the project have the potential to reduce dependence on the Sacramento San Joaquin Bay-Delta?</b>			
<input checked="" type="checkbox"/> Yes	<input type="checkbox"/> No	<input type="checkbox"/> Not Sure	

### Flood Management Benefits

1. Describe how the proposed project will reestablish natural water drainage treatment and infiltration systems, or mimic natural system functions to the maximum extent feasible.
2. Describe how the proposed project will reduce flood risk by reducing runoff rate and/or volume.
3. If applicable, describe how the proposed project will reduce the risk of sanitary sewer overflows.

### Flood Management Benefits (Narrative)

<p>The Project provides a flood management benefit inasmuch as the water delivered to the direct recharge facility during times of stormwater / floodwater management will be diverted and not contribute to increased downstream flows and flood risks. In the case of Semitropic's Water Bank and direct recharge facility, flood flow is delivered via the CA Aqueduct into the District's conveyance system, or, it is delivered via Poso Creek as diverted CVP-Friant or Poso Creek Stormwater, therefore, the added absorptive capacity of direct recharge enhances the ability to receive flows during wet periods, typically corresponding to times of the year when irrigation demand is low.</p> <p>Additionally, the Project also provides for a flood management benefit with the ability to divert wet-year water originating from the Poso Creek Flood Channel into the PPSG recharge ponds and/or the Pond Poso Canal. During flood events on Poso Creek, the recharge ponds could take occurring flood flows, thereby reducing flood damage within the Kern NWR and adjacent valuable agricultural lands.</p>	
Description facilities protected:	Regional conveyance facilities and facilities/land along Poso Creek
Maximum volume of temporary storage of storm water runoff (acre-feet):	1,024 (based on 256 wetted acres x 4 feet deep)
Maximum increased conveyance capacity (cubic feet/second):	350 cfs diverted using Entrance Ponds into PPSGs
Estimated area benefiting from flood damage reduction (acres):	Unknown, qualitatively estimated to be all agricultural lands adjacent to the Poso Creek Flood Channel and the Kern NWR, which have historically been flooded during major flooding events.
Estimated level of flood protection resulting from project implementation (% annual probability of recurrence or 1-in-number of years recurrence):	Unknown
Estimated annual value of flood damage reduction provided by project (\$/year):	Unknown
Land required for project implementation (acres):	320, owned by the District

### For projects that include detention and groundwater recharge, please complete the following:

How many acres of land drain into this detention basin? (acres):	N/A
--	-----

Detention Basin area (acres):	320 gross acres, with 256 net acres
Detention basin max. operational depth (ft.):	4
% of basin covered by wetlands:	N/A
Soil type:	Loam
If other than infiltration, identify method (e.g., injection) and recharge (acre-feet/year):	N/A
Estimated basin annual inflow (acre-feet/year):	1,280 AFY
Estimated basin annual outflow (acre-feet/year):	0



## Environmental and Habitat Enhancement Benefits

Describe how the proposed project identifies opportunities to develop, restore, or enhance habitat and open space through storm water and dry weather runoff management, including wetlands, riverside habitats, parkways, and parks. Provide some type of quantitative measurement, which will show how the project benefits the environment and enhances the natural habitat.

### Environmental and Habitat Enhancement Benefits (Narrative)

The Entrance Ponds to the Pond Poso Spreading Grounds has the potential to create seasonal or intermittent shallow open water habitat by providing benefits for upland habitat to support waterfowl with a place to rest and nest, when water is in the ponds and are being utilized for recharge purposes.

Non-treatment wetland area (acres):	<u>256 acres (320 acres x 80% wetted area), only when being used for direct recharge</u>
Treatment wetland area (acres):	<u>0</u>
Riparian habitat area (acres):	<u>0</u>
Non-developed open space area (acres):	<u>64 acres = (320 gross acres – 256 wetted acres)</u>
Total Project area (acres):	<u>320 gross acres</u>

## Community Stewardship Benefits

Describe how the project identifies opportunities to use existing publicly owned lands and easements, including, but not limited to parks, open space, community gardens, farm and agricultural preserves, school sites, and government office buildings and complexes, to capture, clean, store, and use storm water and dry weather runoff either onsite or offsite. Provide some type of quantitative measurement, which will show how the project benefits the community.

### Community Stewardship Benefits (Narrative)

<p>The Project has the potential for providing project benefits to the community as described below. Once constructed, the facility provides a habitat for various birds and waterfowl that also provides an opportunity for the public to view the waterfowl.</p>
--

**Multiple use/ recreation area (acres) – additionally, select the type of multiple use / recreation and associated acres by type:**

Single Sport Athletics:	<u>N/A</u>
Multiple Sport Athletics Acres:	<u>N/A</u>
Other Recreation Acres:	<u>N/A</u>
Pedestrian Trail Acres:	<u>N/A</u>
Equestrian Trail Acres:	<u>N/A</u>
Other Passive Activity:	<u>Bird viewing</u>
Other Acres (describe):	<u>N/A</u>
Description:	<u>N/A</u>
<b>Total Project Area (acres):</b>	<u>320</u>

## Part 5. Project Cost Estimate

Project cost information is needed to assist in comparing benefits and cost. Additionally, knowledge of the project type and cost will assist in identifying funding sources for potential projects.

Please indicate the estimated costs of project implementation and associated funding source(s). These costs should include land purchase/easement, planning/design/engineering, construction/ implementation, environmental compliance, administration, and contingency.

<b>Approximate Total Cost:</b> (If project costs are variable, please include lower and upper range estimates.)	\$5,000,000 +
<b>Funding Source:</b> (If multiple sources, list each source and the percent or amount funded by each)	<ul style="list-style-type: none"> <li>• Potential future grant funding;</li> <li>• Banking Partners;</li> <li>• District Assessments</li> </ul>
<b>Maximum Funding Match from Implementing Agency:</b>	N/A
<b>Funding Certainty &amp; Longevity:</b>	Unknown
<b>Operations &amp; Maintenance Cost:</b> (per year)	Unknown
<b>Operations &amp; Maintenance Funding Source(s)</b> (i.e., annual budget, grant, etc. If multiple sources, list each source and the percent or amount funded by each.)	Annual Budget
<b>Operations &amp; Maintenance Funding Certainty:</b> (i.e., already included in organization's budget, contingent upon grant, etc.)	Included as part of setting of annual budget

# Kern Storm Water Resource Plan

## Project Submittal Form

This form is to be electronically filled out and e-mailed to [LMarino@ppeng.com](mailto:LMarino@ppeng.com) by June 24, 2016.

Reference: [Storm Water Resource Plan Guidelines](#), December 15, 2015  
State Water Resources Control Board

### Part 1. Lead Implementing Agency/Organizational Information

Please provide the following information regarding the project sponsor and proposed project.

**Implementing Agency / Organization / Individual:**

County of Kern—Public Works Department

**Agency / Organization / Individual Address:**

2700 M Street  
Bakersfield, CA 93301

**Possible Partnering Agencies:**

Arvin-Edison WSD  
Lamont SWD

**Name:**

Craig Pope

**Title:**

Director

**Telephone:**

661-862-5071

**Fax:**

**Email:**

CPOPE@co.kern.ca.us

**Website:**

www.co.kern.ca.us

**Project Name:**

Caliente Creek Habitat Restoration and Groundwater Recharge Projects—Design and Construction

Either the latitude/longitude or a location description is required. To determine the latitude/longitude, use the closest address or intersection. If the project is linear, use the furthest upstream latitude/longitude.

**Project Latitude:**  **Project Longitude:**

<b>Location Description:</b>	Caliente Creek. Near State Route 58 and Arvin, Kern County
------------------------------	--

**Project Cooperating Agency(ies)/Organization(s)/Individual(s):**

• Arvin-Edison WSD
• Lamont SWD
•
•

**Project Status (e.g., new, ongoing, expansion, new phase):**

Ongoing
---------

**Has the Project been submitted to IRWM Plan:**

Kern IRWMP  Poso Creek IRWMP  Not Submitted

**Does the project address any known environmental justice issues?**

Yes  No  Not Sure

**Is the project located within or adjacent to a disadvantaged community (DAC)? Refer to this [website](#).**

Within  Adjacent  No  Not Sure

**Does the project include DAC participation?**

Yes  No  Not Sure

If yes, please identify the contact person, group, or organization and describe the DAC's participation:

The project will benefit both the towns of Lamont and Arvin which comprise of the DAC. The Lamont Storm Water District will participate.
--

**What is the DAC's estimated population:**

Lamont—5,000 and Arvin—10,000
-------------------------------

Does the Implementing Agency own the land where the project is located? If no, describe ability to purchase land or if eminent domain is required:

Yes  No

Will attempt to purchase property.
------------------------------------

## Part 2. Project Need

It is important to understand the need(s) or issue(s) that the proposed project will address and the benefits that it will provide. Information provided in this section defines the need(s) or issue(s) that the proposed project will address and will help to catalog existing need(s) or issue(s) in the planning area of the Kern Storm Water Resource Plan.

Please provide a 1-2 paragraph description of the need(s) or problem(s) that the proposed project will address. Discuss the benefits to water quality, water supply, flood management, environmental, and community benefits that the proposed project will bring. Discuss critical impacts or worsening conditions that will occur if the proposed project is not implemented.

### Project Need (Narrative)

**The Caliente watershed routinely floods the communities of Arvin and Lamont on the average of every 7 years.**

**Currently the first Phase of the Project, the feasibility analysis, is underway. This phase includes designing the most effective layout for plantings for the Habitat Mitigation area, determine the locations for interim irrigation facilities, provide preliminary designs for the ground water storage basins and required headworks and assess the economic costs and benefits associated with both of the projects. This analysis will be a vital component and the basis for applying for future implementation/construction grants.**

**Future phases will include processing of the CEQA document, acquisition of lands, final design for the recharge basins, grading/construction of facilities and site revegetation.**

**The design and construction phases will include two projects to force a slowing and energy dissipation of flows, increase sediment deposition, increase volume losses, reclaim approximately 1,500 acres as natural habitat, and to utilize drainage areas for the groundwater recharge.**

**It is estimated the entire project will cost approximately \$50,000,000 to construct.**

### Part 3. Project Description

A general description of the proposed project is needed. This section will provide information associated with the project concept and general project information. Much of the requested information may not be available for projects that are in the conceptual stages of development. An essential element of the Kern Storm Water Resource Plan consists of proposed projects. We appreciate and need your ideas.

Please provide a one or two paragraph description of the project including the general project concept, what will be constructed/implemented, how the constructed project will function, what technologies or methods will be used, as appropriate. For water quality projects, include a description of impacts to existing Total Maximum Daily Loads, NPDES permits, and/or waste discharge requirements.

**Project Description (Narrative)**

<p>Currently the first Phase of the Project, the feasibility analysis, is underway.</p> <p>Subsequent phases will include processing of the CEQA document, acquisition of lands, final design for the recharge basins, grading/construction of facilities and site revegetation.</p> <p>The design and construction phase includes two projects:</p> <p><u>The Caliente Creek Habitat Mitigation Project</u> will create a riparian forest upstream of Highway 58 in order to affect flood control and water clarification/purification. There are five direct goals of this project: Decrease site erosion by slowing the velocity of the flow; Increase sediment deposition; Increase groundwater recharge; Reclaim this 1,300 acre area as natural habitat; Clarify and purify the waters crossing this alluvial floodplain.</p> <p><u>The Caliente Creek Ground Water Recharge Project</u> lies south of the Habitat Mitigation Project and covers approximately 1,500 acres of land between Highway 58 and the Tamarisk Tree line south of the highway. Flows passing under Highway 58 at either the Caliente Creek Bridge or the Neumarkel underpass would be directed into storage basins for ground water recharge.</p>
---

**If applicable, list surface water bodies and groundwater basins associated with the proposed project:**

<ul style="list-style-type: none"> <li>• Caliente Creek</li> </ul>
<ul style="list-style-type: none"> <li>•</li> </ul>
<ul style="list-style-type: none"> <li>•</li> </ul>
<ul style="list-style-type: none"> <li>•</li> </ul>

**Please identify up to three available documents which contain information specific to the proposed project. Include conceptual plans, permits, drawings, and technical documents:**

<ul style="list-style-type: none"> <li>• CRMP</li> </ul>
<ul style="list-style-type: none"> <li>• IRWMP Project Form</li> </ul>
<ul style="list-style-type: none"> <li>• AECOM study (currently underway)</li> </ul>

Please identify federal, state, or local permits, which pertain to the proposed project and would need to be obtained or, if existing, would need to be amended:

<ul style="list-style-type: none"> <li>Local grading permit</li> </ul>
<ul style="list-style-type: none"> <li></li> </ul>
<ul style="list-style-type: none"> <li></li> </ul>

Please identify any existing projects or facilities, including existing water conveyance infrastructure, which would be affected, modified, or superseded as a result of implementing the proposed project:

<ul style="list-style-type: none"> <li></li> </ul>
<ul style="list-style-type: none"> <li></li> </ul>
<ul style="list-style-type: none"> <li></li> </ul>

Is the proposed project an element or phase of a regional or larger program?:	<input type="checkbox"/> Yes	<input checked="" type="checkbox"/> No
If yes, please identify the program:		
Design life of the project:		
Proposed Construction/Implementation Start Date:	June 2016—Feasibility Study (underway) June 2017—Design and Construction	
Proposed Construction/Implementation Completion Date:	January 2017—Feasibility Study January 2019—Design and Construction	
Ready for Construction Bid:	<input type="checkbox"/> Yes	<input checked="" type="checkbox"/> No <input type="checkbox"/> N/A

Item	Status (e.g., not initiated, in process, complete)	Date (mm/dd/yyyy)
Conceptual Plans	<b>In process</b>	06/28/2016
Land Acquisition/ Easements	<b>Not initiated</b>	
Preliminary Plans	<b>Not initiated</b>	
CEQA/NEPA	<b>Not initiated</b>	
Permits	<b>Not initiated</b>	
Construction Drawings	<b>Not initiated</b>	

For projects ready for construction or implementation, including projects which do not include construction, briefly describe the project's readiness to proceed.



**Project Readiness (Narrative)**

The feasibility study is in progress.

Include any local or state board actions, code changes, or legislation needed in order to proceed with the project.

**Local or State Board Actions, Code Changes, or Legislation**

State approval for grant, if not then no project  
Local approval for project and local financial participation

**Please describe the dominant existing land use type for the proposed project location.**

agricultural

**Please describe the dominant existing land use type for areas upstream and downstream of the proposed project location**

Upstream:	Agricultural and grazing land
Downstream:	Agricultural

## Part 4. Project Benefits

Please provide a one or two paragraph description of the benefit(s) that the project will address. Benefit Categories, shown below, are referenced from the [Storm Water Resource Plan Guidelines](#), Page 31, Table 4. Each project should address at least two or more Main Benefits and as many Additional Benefits as feasible. Information you provide will be used to evaluate the project for State grant funding.

Storm Water Management Benefits		
Benefit Category	Main Benefit	Additional Benefit
<b>Water Quality</b> (while contributing to compliance with applicable permit and/or TMDL requirements)	<ul style="list-style-type: none"> <li>Increased filtration and/or treatment of run-off</li> </ul>	<ul style="list-style-type: none"> <li>Non-point source pollution control</li> <li>Reestablished natural water drainage and treatment</li> </ul>
<b>Water Supply</b> (through groundwater management and/or run-off capture and use)	<ul style="list-style-type: none"> <li>Water supply reliability</li> <li>Conjunctive use</li> </ul>	<ul style="list-style-type: none"> <li>Water conservation</li> </ul>
<b>Flood Management</b>	<ul style="list-style-type: none"> <li>Decreased flood risk by reducing run-off rate and/or volume</li> </ul>	<ul style="list-style-type: none"> <li>Reduced sanitary sewer overflows</li> </ul>
<b>Environmental and Habitat Enhancement</b>	<ul style="list-style-type: none"> <li>Environmental and habitat protection and improvement, including;                             <ul style="list-style-type: none"> <li>wetland enhancement/creation;</li> <li>riparian enhancement; and/or</li> <li>instream flow improvement</li> </ul> </li> <li>Increased urban green space</li> </ul>	<ul style="list-style-type: none"> <li>Reduced energy use, greenhouse gas emissions, or provides a carbon sink</li> <li>Reestablishment of the natural hydrograph</li> <li>Water temperature improvements</li> </ul>
<b>Community Stewardship</b>	<ul style="list-style-type: none"> <li>Employment opportunities provided</li> <li>Public Education</li> </ul>	<ul style="list-style-type: none"> <li>Community involvement</li> <li>Enhance and/or create recreational and public use areas</li> </ul>

Source: Page 31, Table 4, Storm Water Resource Plan Guidelines, State Water Resources Control Board

Please provide the following **PROJECT BENEFIT** information for all applicable components of the proposed project. Benefit categories include:

- **Water Quality**
- **Water Supply**
- **Flood Management**
- **Environmental and Habitat Enhancement**
- **Community Stewardship**

If the project benefits a disadvantaged community (DAC) describe the specific benefits to that community. Estimate the percentage of the project benefits to the DAC.

Please supply all information relevant to the proposed project. The information you provide will be used to evaluate the project for State grant funding. **Attach additional sheets if necessary.**

## Water Quality Benefits

1. Describe how the proposed project will improve source control for both pollution and dry weather runoff volume, onsite and local infiltration, and use of storm water and dry weather runoff.
2. Describe design criteria and best management practices to prevent storm water and dry weather runoff pollution and increase effective storm water and dry weather runoff management for new and upgraded infrastructure and residential, commercial, industrial, and public development
3. Describe how the proposed project complies with or is consistent with an applicable NPDES permit. The analysis should simulate the proposed watershed-based outcomes using modeling, calculations, pollutant mass balances, water volume balances, and/or other methods of analysis. Describe how the proposed project will contribute to the preservation, restoration, or enhancement of watershed processes (as described in Guidelines section VI.C.2.a)
4. Describe the water quality monitoring and data acquisition that will be implemented in conjunction with the proposed project. Describe the a) mechanisms by which data will be managed and stored; b) how data will be accessed by stakeholders and the public; c) how existing water quality and water quality monitoring will be assessed; d) frequency at which data will be updated; and e) how data gaps will be identified.

### Water Quality Benefits (Narrative)

<b>The project will help control flooding which will decrease the sediment deposition downstream.</b>	
Pollutant TMDL reduction (Volume per day) and (mass /unit volume) of most probable number of bacteria or indicator organisms (mpn/mL):	No TMDL established for Caliente Creek
Increase in infiltration rate above existing condition:	Increase in infiltration rate with construction of groundwater recharge basins
Non-point source pollution control:	Decrease in sediment deposition downstream
Does project affect an Existing NPDES Permit? If applicable, describe the need for a new NPDES Permit:	Project area not within NPDES permit area.

## Water Supply Benefits

1. Describe how the proposed project captures and reuses storm water and dry weather runoff for groundwater recharge or storage for beneficial use.
2. Please provide detailed information to quantify how the proposed project will reduce existing potable water demand.
3. Describe the water supply monitoring and data acquisition that will be implemented in conjunction with the proposed project. Describe the a) mechanisms by which data will be managed and stored; b) how data will be accessed by stakeholders and the public; c) how existing water quality and water quality monitoring will be assessed; d) frequency at which data will be updated; and e) how data gaps will be identified

### Water Supply Benefits (Narrative)

<p><b>The capture of storm water and flood flows in proposed groundwater recharge basins will provide additional water to underlying aquifers.</b></p>
--

### Enhanced Water Supply or Demand Reduction Benefit Information

<b>Source of Increased Supply or Demand Reduction</b>	
<input checked="" type="checkbox"/> Groundwater <input type="checkbox"/> Recycled water <input type="checkbox"/> Transfer	<input type="checkbox"/> Groundwater treatment <input checked="" type="checkbox"/> Conservation/ water use efficiency <input type="checkbox"/> Other (describe):
<input checked="" type="checkbox"/> Increased surface water storage <input type="checkbox"/> Ocean desalination	
Type of enhanced supply or demand reduction:	Retention of storm water from rain and flood events.
Annual Yield of Supply (acre-feet):	Not yet determined
<b>Availability by Water-Year Type (acre-feet per year)</b>	
Average Year:	To be determined
Dry Year:	To be determined
Wet Year:	To be determined
<b>Availability by Season (check all that apply):</b>	
<input checked="" type="checkbox"/> Summer <input checked="" type="checkbox"/> Fall <input checked="" type="checkbox"/> Spring <input checked="" type="checkbox"/> Winter	
<b>Does the project have the potential to displace demands on the Bay/Delta/Estuary?</b>	
<input checked="" type="checkbox"/> Yes <input type="checkbox"/> No <input type="checkbox"/> Not Sure	

## Flood Management Benefits

1. Describe how the proposed project will reestablish natural water drainage treatment and infiltration systems, or mimic natural system functions to the maximum extent feasible.
2. Describe how the proposed project will reduce flood risk by reducing runoff rate and/or volume.
3. If applicable, describe how the proposed project will reduce the risk of sanitary sewer overflows.

### Flood Management Benefits (Narrative)

Approximately 1,500 acres is proposed to be converted back to natural riparian habitat upstream of the proposed groundwater recharge basins. This riparian habitat will provide natural treatment and infiltration to waters flowing in Caliente Creek. The proposed groundwater recharge basins will capture and meter flow and thus reduce the flooding issues presently downstream.	
Maximum volume of temporary storage of storm water runoff (acre-feet):	Information not available at this time
Maximum increased conveyance capacity (cubic feet/second):	Information not available at this time
Estimated area benefiting from flood damage reduction (acres):	Information not available at this time
Estimated level of flood protection resulting from project implementation (% annual probability of recurrence or 1-in-number of years recurrence):	Information not available at this time
Estimated annual value of flood damage reduction provided by project (\$/year):	Information not available at this time
Land required for project implementation (acres):	1,500

### For projects that include detention and groundwater recharge, please complete the following:

How many acres of land drain into this detention basin? (acres):	1,500 +/-
Detention Basin area (acres):	To be determined
Detention basin max. operational depth (ft.):	To be determined
% of basin covered by wetlands:	N/A
Soil type:	varies
If other than infiltration, identify method (e.g., injection) and recharge (acre-feet/year):	No other methods identified
Estimated basin annual inflow (acre-feet/year):	To be determined
Estimated basin annual outflow (acre-feet/year):	To be determined

## Environmental and Habitat Enhancement Benefits

Describe how the proposed project identifies opportunities to develop, restore, or enhance habitat and open space through storm water and dry weather runoff management, including wetlands, riverside habitats, parkways, and parks. Provide some type of quantitative measurement, which will show how the project benefits the environment and enhances the natural habitat.

### Environmental and Habitat Enhancement Benefits (Narrative)

The Caliente Creek Habitat Mitigation project proposes the conversion of approximately 1,300 acres back to riparian habitat. Currently most of the area is under cultivation. It is proposed to re-introduce native plant species to help maintain a diverse population in the region.

Non-treatment wetland area (acres):	none
Treatment wetland area (acres):	none
Riparian habitat area (acres):	1,300 +/-
Non-developed open space area (acres):	All non-developed
Total Project area (acres):	1,300 +/-

## Community Stewardship Benefits

Describe how the project identifies opportunities to use existing publicly owned lands and easements, including, but not limited to parks, open space, community gardens, farm and agricultural preserves, school sites, and government office buildings and complexes, to capture, clean, store, and use storm water and dry weather runoff either onsite or offsite. Provide some type of quantitative measurement, which will show how the project benefits the community.

### Community Stewardship Benefits (Narrative)

Currently there will be no community/public projects to utilize storm water other than for ground water recharge.
---

**Multiple use/ recreation area (acres) – additionally, select the type of multiple use / recreation and associated acres by type:**

Single Sport Athletics:	N/A
Multiple Sport Athletics Acres:	N/A
Other Recreation Acres:	N/A
Pedestrian Trail Acres:	N/A
Equestrian Trail Acres:	N/A
Other Passive Activity:	N/A
Other Acres (describe):	N/A
Description:	N/A
<b>Total Project Area (acres):</b>	0

## Part 5. Project Cost Estimate

Project cost information is needed to assist in comparing benefits and cost. Additionally, knowledge of the project type and cost will assist in identifying funding sources for potential projects.

Please indicate the estimated costs of project implementation and associated funding source(s). These costs should include land purchase/easement, planning/design/engineering, construction/ implementation, environmental compliance, administration, and contingency.

<b>Approximate Total Cost:</b> (If project costs are variable, please include lower and upper range estimates.)	Design and Construction Phase 1--\$10,000,000 (total project--\$50,000,000)
<b>Funding Source:</b> (If multiple sources, list each source and the percent or amount funded by each)	Kern County Public Works—general fund budget State and Federal Grants
<b>Maximum Funding Match from Implementing Agency:</b>	To be determined
<b>Funding Certainty &amp; Longevity:</b>	To be determined
<b>Operations &amp; Maintenance Cost:</b> (per year)	To be determined
<b>Operations &amp; Maintenance Funding Source(s)</b> (i.e., annual budget, grant, etc. If multiple sources, list each source and the percent or amount funded by each.)	To be determined
<b>Operations &amp; Maintenance Funding Certainty:</b> (i.e., already included in organization's budget, contingent upon grant, etc.)	To be determined



# Kern Storm Water Resource Plan

## Project Submittal Form

This form is to be electronically filled out and e-mailed to [LMarino@ppeng.com](mailto:LMarino@ppeng.com) by June 24, 2016.

Reference: [Storm Water Resource Plan Guidelines](#), December 15, 2015  
State Water Resources Control Board

### Part 1. Lead Implementing Agency/Organizational Information

Please provide the following information regarding the project sponsor and proposed project.

**Implementing Agency / Organization / Individual:**

County of Kern—Public Works Department

**Agency / Organization / Individual Address:**

2700 M Street  
Bakersfield, CA 93301

**Possible Partnering Agencies:**

**Name:**

Craig Pope

**Title:**

Director

**Telephone:**

661-862-5100

**Fax:**

**Email:**

CPOPE@co.kern.ca.us

**Website:**

www.co.kern.ca.us

**Project Name:**

Cuddy Creek Restoration Project

Either the latitude/longitude or a location description is required. To determine the latitude/longitude, use the closest address or intersection. If the project is linear, use the furthest upstream latitude/longitude.

**Project Latitude:**  **Project Longitude:**

<b>Location Description:</b>	This project is located at Cuddy Creek in Frazier Park, Kern County
------------------------------	---

**Project Cooperating Agency(ies)/Organization(s)/Individual(s):**

- |   |
|---|
| • Frazier Park Adopt-A-Creek (local citizens group) |
| •   |
| •   |
| •   |

**Project Status (e.g., new, ongoing, expansion, new phase):**

**Has the Project been submitted to IRWM Plan:**

Kern IRWMP  Poso Creek IRWMP  Not Submitted

**Does the project address any known environmental justice issues?**

Yes  No  Not Sure

**Is the project located within or adjacent to a disadvantaged community (DAC)? Refer to this [website](#).**

Within  Adjacent  No  Not Sure

**Does the project include DAC participation?**

Yes  No  Not Sure

If yes, please identify the contact person, group, or organization and describe the DAC's participation:

Frazier Park is considered a DAC. Community and civic organizations are interested in participation in the process.

What is the DAC's estimated population:

Frazier Park—2,800

Does the Implementing Agency own the land where the project is located? If no, describe ability to purchase land or if eminent domain is required:

Yes  No

Will attempt to purchase.

## Part 2. Project Need

It is important to understand the need(s) or issue(s) that the proposed project will address and the benefits that it will provide. Information provided in this section defines the need(s) or issue(s) that the proposed project will address and will help to catalog existing need(s) or issue(s) in the planning area of the Kern Storm Water Resource Plan.

Please provide a 1-2 paragraph description of the need(s) or problem(s) that the proposed project will address. Discuss the benefits to water quality, water supply, flood management, environmental, and community benefits that the proposed project will bring. Discuss critical impacts or worsening conditions that will occur if the proposed project is not implemented.

### Project Need (Narrative)

**This construction project would restore a portion of Cuddy Creek through the town of Frazier Park. The project consists of constructing a series of rock groins and planted groins to force the stream into a meandering path to slow the flow, reduce energy, and thereby reduce the negative effects of erosion, degradation and aggradations. The slowing effect will also provide an opportunity for additional ground water recharge, which is much needed in the aquifer serving the Lake of the Woods and adjacent areas.**

### Part 3. Project Description

A general description of the proposed project is needed. This section will provide information associated with the project concept and general project information. Much of the requested information may not be available for projects that are in the conceptual stages of development. An essential element of the Kern Storm Water Resource Plan consists of proposed projects. We appreciate and need your ideas.

Please provide a one or two paragraph description of the project including the general project concept, what will be constructed/implemented, how the constructed project will function, what technologies or methods will be used, as appropriate. For water quality projects, include a description of impacts to existing Total Maximum Daily Loads, NPDES permits, and/or waste discharge requirements.

**Project Description (Narrative)**

<p>In general, the project consists of stabilization and restoration of approximately 3000 feet of Cuddy Creek. Construction will include grade control structures, planted groins, and vegetation groins. The purpose of this project is to reduce watershed soil erosion and sedimentation of surface water to reduce the discharge of pollutants to State waters from storm or nonpoint sources. Slowing the water will also provide additional ground water recharge.</p>
---

**If applicable, list surface water bodies and groundwater basins associated with the proposed project:**

<ul style="list-style-type: none"> <li>• Cuddy Creek</li> </ul>
<ul style="list-style-type: none"> <li>•</li> </ul>
<ul style="list-style-type: none"> <li>•</li> </ul>
<ul style="list-style-type: none"> <li>•</li> </ul>

**Please identify up to three available documents which contain information specific to the proposed project. Include conceptual plans, permits, drawings, and technical documents:**

<ul style="list-style-type: none"> <li>• 2008 Urban Stream Restoration Program, Grant Application dated 11/12/2008</li> </ul>
<ul style="list-style-type: none"> <li>• Preliminary Design and Feasibility Report by Questa Engineering - November, 2003</li> </ul>
<ul style="list-style-type: none"> <li>• Final Design Report by Questa Engineering - April, 2004</li> </ul>

Please identify federal, state, or local permits, which pertain to the proposed project and would need to be obtained or, if existing, would need to be amended:

• Local grading permit
• Fish & Game
• US Corp of Engineers

Please identify any existing projects or facilities, including existing water conveyance infrastructure, which would be affected, modified, or superseded as a result of implementing the proposed project:

•
•
•

Is the proposed project an element or phase of a regional or larger program?:	<input type="checkbox"/> Yes	<input checked="" type="checkbox"/> No
If yes, please identify the program:		
Design life of the project:	50 years	
Proposed Construction/Implementation Start Date:	May 2017	
Proposed Construction/Implementation Completion Date:	November 2017	
Ready for Construction Bid:	<input type="checkbox"/> Yes	<input checked="" type="checkbox"/> No <input type="checkbox"/> N/A

Item	Status (e.g., not initiated, in process, complete)	Date (mm/dd/yyyy)
Conceptual Plans	<b>Completed</b>	4/1/2004
Land Acquisition/ Easements	<b>Not Initiated</b>	
Preliminary Plans	<b>Completed</b>	4/1/2004
CEQA/NEPA	<b>Incomplete</b>	
Permits	<b>Not Initiated</b>	
Construction Drawings	<b>Incomplete</b>	

For projects ready for construction or implementation, including projects which do not include construction, briefly describe the project's readiness to proceed.

**Project Readiness (Narrative)**

There are preliminary plans completed with enough details to start the project.

Include any local or state board actions, code changes, or legislation needed in order to proceed with the project.

**Local or State Board Actions, Code Changes, or Legislation**

State approval grants  
Local approval for project and local financial participation

**Please describe the dominant existing land use type for the proposed project location.**

Project location is Cuddy Creek Streambed Channel, bordered by residential and commercial.

**Please describe the dominant existing land use type for areas upstream and downstream of the proposed project location**

Upstream:	Stream channel bordered by residential and commercial.
Downstream:	Stream channel bordered by residential and commercial.

## Part 4. Project Benefits

Please provide a one or two paragraph description of the benefit(s) that the project will address. Benefit Categories, shown below, are referenced from the [Storm Water Resource Plan Guidelines](#), Page 31, Table 4. Each project should address at least two or more Main Benefits and as many Additional Benefits as feasible. Information you provide will be used to evaluate the project for State grant funding.

Storm Water Management Benefits		
Benefit Category	Main Benefit	Additional Benefit
<b>Water Quality</b> (while contributing to compliance with applicable permit and/or TMDL requirements)	<ul style="list-style-type: none"> <li>Increased filtration and/or treatment of run-off</li> </ul>	<ul style="list-style-type: none"> <li>Non-point source pollution control</li> <li>Reestablished natural water drainage and treatment</li> </ul>
<b>Water Supply</b> (through groundwater management and/or run-off capture and use)	<ul style="list-style-type: none"> <li>Water supply reliability</li> <li>Conjunctive use</li> </ul>	<ul style="list-style-type: none"> <li>Water conservation</li> </ul>
<b>Flood Management</b>	<ul style="list-style-type: none"> <li>Decreased flood risk by reducing run-off rate and/or volume</li> </ul>	<ul style="list-style-type: none"> <li>Reduced sanitary sewer overflows</li> </ul>
<b>Environmental and Habitat Enhancement</b>	<ul style="list-style-type: none"> <li>Environmental and habitat protection and improvement, including;                             <ul style="list-style-type: none"> <li>wetland enhancement/creation;</li> <li>riparian enhancement; and/or</li> <li>instream flow improvement</li> </ul> </li> <li>Increased urban green space</li> </ul>	<ul style="list-style-type: none"> <li>Reduced energy use, greenhouse gas emissions, or provides a carbon sink</li> <li>Reestablishment of the natural hydrograph</li> <li>Water temperature improvements</li> </ul>
<b>Community Stewardship</b>	<ul style="list-style-type: none"> <li>Employment opportunities provided</li> <li>Public Education</li> </ul>	<ul style="list-style-type: none"> <li>Community involvement</li> <li>Enhance and/or create recreational and public use areas</li> </ul>

Source: Page 31, Table 4, Storm Water Resource Plan Guidelines, State Water Resources Control Board

Please provide the following **PROJECT BENEFIT** information for all applicable components of the proposed project. Benefit categories include:

- **Water Quality**
- **Water Supply**
- **Flood Management**
- **Environmental and Habitat Enhancement**
- **Community Stewardship**

If the project benefits a disadvantaged community (DAC) describe the specific benefits to that community. Estimate the percentage of the project benefits to the DAC.

Please supply all information relevant to the proposed project. The information you provide will be used to evaluate the project for State grant funding. **Attach additional sheets if necessary.**

## Water Quality Benefits

1. Describe how the proposed project will improve source control for both pollution and dry weather runoff volume, onsite and local infiltration, and use of storm water and dry weather runoff.
2. Describe design criteria and best management practices to prevent storm water and dry weather runoff pollution and increase effective storm water and dry weather runoff management for new and upgraded infrastructure and residential, commercial, industrial, and public development
3. Describe how the proposed project complies with or is consistent with an applicable NPDES permit. The analysis should simulate the proposed watershed-based outcomes using modeling, calculations, pollutant mass balances, water volume balances, and/or other methods of analysis. Describe how the proposed project will contribute to the preservation, restoration, or enhancement of watershed processes (as described in Guidelines section VI.C.2.a)
4. Describe the water quality monitoring and data acquisition that will be implemented in conjunction with the proposed project. Describe the a) mechanisms by which data will be managed and stored; b) how data will be accessed by stakeholders and the public; c) how existing water quality and water quality monitoring will be assessed; d) frequency at which data will be updated; and e) how data gaps will be identified.

### Water Quality Benefits (Narrative)

<p>The proposed project includes the construction/placement of grade control structures, planted groins, and vegetation groins. The purpose of this project is to reduce watershed soil erosion and sedimentation of surface water to reduce the discharge of pollutants to State waters from storm or nonpoint sources.</p>	
<p>Pollutant TMDL reduction (Volume per day) and (mass /unit volume) of most probable number of bacteria or indicator organisms (mpn/mL):</p>	<p>Cuddy Creek does not have a TMDL</p>
<p>Increase in infiltration rate above existing condition:</p>	<p>No anticipated increase in the infiltration rate</p>
<p>Non-point source pollution control:</p>	<p>Will help control erosion and sedimentation issues</p>
<p>Does project affect an Existing NPDES Permit? If applicable, describe the need for a new NPDES Permit:</p>	<p>Project will not affect an existing NPDES permit.</p>



## Water Supply Benefits

1. Describe how the proposed project captures and reuses storm water and dry weather runoff for groundwater recharge or storage for beneficial use.
2. Please provide detailed information to quantify how the proposed project will reduce existing potable water demand.
3. Describe the water supply monitoring and data acquisition that will be implemented in conjunction with the proposed project. Describe the a) mechanisms by which data will be managed and stored; b) how data will be accessed by stakeholders and the public; c) how existing water quality and water quality monitoring will be assessed; d) frequency at which data will be updated; and e) how data gaps will be identified

### Water Supply Benefits (Narrative)

<p><b>The groins will slow the water and provide areas of additional groundwater infiltration and recharge.</b></p>
---

### Enhanced Water Supply or Demand Reduction Benefit Information

<b>Source of Increased Supply or Demand Reduction</b>	
<input checked="" type="checkbox"/> Groundwater	<input type="checkbox"/> Groundwater treatment
<input type="checkbox"/> Recycled water	<input checked="" type="checkbox"/> Conservation/ water use efficiency
<input type="checkbox"/> Transfer	<input type="checkbox"/> Other (describe):
<input type="checkbox"/> Increased surface water storage	<input type="checkbox"/> Ocean desalination
Type of enhanced supply or demand reduction:	Groundwater recharge
Annual Yield of Supply (acre-feet):	unknown
<b>Availability by Water-Year Type (acre-feet per year)</b>	
Average Year:	<u>Not determined</u>
Dry Year:	<u>Not determined</u>
Wet Year:	<u>Not determined</u>
<b>Availability by Season (check all that apply):</b>	
<input checked="" type="checkbox"/> Summer	<input checked="" type="checkbox"/> Fall
<input checked="" type="checkbox"/> Spring	<input checked="" type="checkbox"/> Winter
<b>Does the project have the potential to displace demands on the Bay/Delta/Estuary?</b>	
<input checked="" type="checkbox"/> Yes	<input type="checkbox"/> No
<input type="checkbox"/> Not Sure	

## Flood Management Benefits

1. Describe how the proposed project will reestablish natural water drainage treatment and infiltration systems, or mimic natural system functions to the maximum extent feasible.
2. Describe how the proposed project will reduce flood risk by reducing runoff rate and/or volume.
3. If applicable, describe how the proposed project will reduce the risk of sanitary sewer overflows.

### Flood Management Benefits (Narrative)

<p>The channel erosion has stripped all of the top soil from much of the channel bed leaving barren rock. As these banks erode laterally, homes that were originally constructed a safe distance from the creek may now become placed in peril. This project will prevent further watershed soil erosion and reduce the discharge of pollutants to State waters from storm or nonpoint sources.</p>	
Maximum volume of temporary storage of storm water runoff (acre-feet):	N/A
Maximum increased conveyance capacity (cubic feet/second):	N/A
Estimated area benefiting from flood damage reduction (acres):	About two acres which is adjacent or within the channel +/- 3000 lf.
Estimated level of flood protection resulting from project implementation (% annual probability of recurrence or 1-in-number of years recurrence):	Uncertain
Estimated annual value of flood damage reduction provided by project (\$/year):	N/A
Land required for project implementation (acres):	Uncertain

### For projects that include detention and groundwater recharge, please complete the following:

How many acres of land drain into this detention basin? (acres):	N/A
Detention Basin area (acres):	N/A
Detention basin max. operational depth (ft.):	N/A
% of basin covered by wetlands:	N/A
Soil type:	N/A
If other than infiltration, identify method (e.g., injection) and recharge (acre-feet/year):	N/A
Estimated basin annual inflow (acre-feet/year):	N/A
Estimated basin annual outflow (acre-feet/year):	N/A

## Environmental and Habitat Enhancement Benefits

Describe how the proposed project identifies opportunities to develop, restore, or enhance habitat and open space through storm water and dry weather runoff management, including wetlands, riverside habitats, parkways, and parks. Provide some type of quantitative measurement, which will show how the project benefits the environment and enhances the natural habitat.

### Environmental and Habitat Enhancement Benefits (Narrative)

The Cuddy Creek Restoration Project will use planted groins and rock groins to re-establish natural controls to mitigate and reduce the dangerously uncontrolled erosion problems. Cuddy Creek will be less capable of lateral migration (less bank erosion) and should develop meadows where there is currently only bare rock and/or poorly graded sediments. Once established, the restored riparian corridor will provide an ideal habitat for trout (Cuddy Creek is annually stocked with trout) and native wildlife.

Non-treatment wetland area (acres):	N/A
Treatment wetland area (acres):	N/A
Riparian habitat area (acres):	<u>About two acres which is adjacent or within the channel +/- 3000 lf.</u>
Non-developed open space area (acres):	N/A
Total Project area (acres):	<u>About 3 acres</u>

## Community Stewardship Benefits

Describe how the project identifies opportunities to use existing publicly owned lands and easements, including, but not limited to parks, open space, community gardens, farm and agricultural preserves, school sites, and government office buildings and complexes, to capture, clean, store, and use storm water and dry weather runoff either onsite or offsite. Provide some type of quantitative measurement, which will show how the project benefits the community.

### Community Stewardship Benefits (Narrative)

<p>It is anticipated the community would be involved in planting some trees along the banks and on the rock groins and the meandering sidewalk along Cuddy Creek would lend itself to the locals appreciating the new riparian habitat and participate in maintenance and beautification of the community.</p>
--

**Multiple use/ recreation area (acres) – additionally, select the type of multiple use / recreation and associated acres by type:**

Single Sport Athletics:	N/A
Multiple Sport Athletics Acres:	N/A
Other Recreation Acres:	N/A
Pedestrian Trail Acres:	N/A
Equestrian Trail Acres:	N/A
Other Passive Activity:	N/A
Other Acres (describe):	N/A
Description:	N/A
<b>Total Project Area (acres):</b>	0

## Part 5. Project Cost Estimate

Project cost information is needed to assist in comparing benefits and cost. Additionally, knowledge of the project type and cost will assist in identifying funding sources for potential projects.

Please indicate the estimated costs of project implementation and associated funding source(s). These costs should include land purchase/easement, planning/design/engineering, construction/ implementation, environmental compliance, administration, and contingency.

<b>Approximate Total Cost:</b> (If project costs are variable, please include lower and upper range estimates.)	\$2,000,000
<b>Funding Source:</b> (If multiple sources, list each source and the percent or amount funded by each)	Kern County general fund. State and Federal Grants.
<b>Maximum Funding Match from Implementing Agency:</b>	To be determined
<b>Funding Certainty &amp; Longevity:</b>	To be determined
<b>Operations &amp; Maintenance Cost:</b> (per year)	To be determined
<b>Operations &amp; Maintenance Funding Source(s)</b> (i.e., annual budget, grant, etc. If multiple sources, list each source and the percent or amount funded by each.)	to be determined
<b>Operations &amp; Maintenance Funding Certainty:</b> (i.e., already included in organization's budget, contingent upon grant, etc.)	To be determined

# Kern Storm Water Resource Plan

## Project Submittal Form

This form is to be electronically filled out and e-mailed to [LMarino@ppeng.com](mailto:LMarino@ppeng.com) by June 24, 2016.

Reference: [Storm Water Resource Plan Guidelines](#), December 15, 2015  
State Water Resources Control Board

### Part 1. Lead Implementing Agency/Organizational Information

Please provide the following information regarding the project sponsor and proposed project.

**Implementing Agency / Organization / Individual:**

County of Kern—Public Works Department

**Agency / Organization / Individual Address:**

2700 M Street  
Bakersfield, CA 93301

**Possible Partnering Agencies:**

City of Taft

**Name:**

Craig Pope

**Title:**

Director

**Telephone:**

661-862-5100

**Fax:**

**Email:**

CPOPE@co.kern.ca.us

**Website:**

www.co.kern.ca.us

**Project Name:**

Sandy Creek Bank and Erosion Protection Project

Either the latitude/longitude or a location description is required. To determine the latitude/longitude, use the closest address or intersection. If the project is linear, use the furthest upstream latitude/longitude.

**Project Latitude:**  **Project Longitude:**

<b>Location Description:</b>	Ford City Area, Kern County.
------------------------------	------------------------------

**Project Cooperating Agency(ies)/Organization(s)/Individual(s):**

• City of Taft
•
•
•

**Project Status (e.g., new, ongoing, expansion, new phase):**

New
-----

**Has the Project been submitted to IRWM Plan:**

Kern IRWMP  Poso Creek IRWMP  Not Submitted

**Does the project address any known environmental justice issues?**

Yes  No  Not Sure

**Is the project located within or adjacent to a disadvantaged community (DAC)? Refer to this [website](#).**

Within  Adjacent  No  Not Sure

**Does the project include DAC participation?**

Yes  No  Not Sure

If yes, please identify the contact person, group, or organization and describe the DAC's participation:

The City of Taft is incorporated and would be represented by their city council. Ford City is unincorporated and would be represented by the County Board of Supervisors.
---

What is the DAC's estimated population:

City of Taft—9,000 and Ford City—4,500
--

Does the Implementing Agency own the land where the project is located? If no, describe ability to purchase land or if eminent domain is required:

Yes  No

Will attempt to purchase
--------------------------

## Part 2. Project Need

It is important to understand the need(s) or issue(s) that the proposed project will address and the benefits that it will provide. Information provided in this section defines the need(s) or issue(s) that the proposed project will address and will help to catalog existing need(s) or issue(s) in the planning area of the Kern Storm Water Resource Plan.

Please provide a 1-2 paragraph description of the need(s) or problem(s) that the proposed project will address. Discuss the benefits to water quality, water supply, flood management, environmental, and community benefits that the proposed project will bring. Discuss critical impacts or worsening conditions that will occur if the proposed project is not implemented.

### Project Need (Narrative)

**Sandy Creek runs through the urban (both incorporated and unincorporated) areas around the City of Taft and Ford City. The Sandy Creek channel is under-sized and frequently causes flooding issues for the City of Taft and Ford City areas. Not performing any improvements will result in continued erosion and eventual failure of the levee jeopardizing adjacent property, homes, and businesses.**



### Part 3. Project Description

A general description of the proposed project is needed. This section will provide information associated with the project concept and general project information. Much of the requested information may not be available for projects that are in the conceptual stages of development. An essential element of the Kern Storm Water Resource Plan consists of proposed projects. We appreciate and need your ideas.

Please provide a one or two paragraph description of the project including the general project concept, what will be constructed/implemented, how the constructed project will function, what technologies or methods will be used, as appropriate. For water quality projects, include a description of impacts to existing Total Maximum Daily Loads, NPDES permits, and/or waste discharge requirements.

**Project Description (Narrative)**

The Meyer Civil Engineering Hydrology Report proposes the construction of a detention basin at Midoil Road (west of Ford City and the City of Taft). The detention basin would be designed to reduce the 100 year inflow peak from 2,139 CFS to 848 CSF by storing 187 acre feet of water. This reduction at Midoil Road is continued all the way to the North Sandy Creek confluence where flows would be reduced from 5,052 CFS to 4,076 CFS. There will be groins, grade control structures and bank armoring will also be constructed.

**If applicable, list surface water bodies and groundwater basins associated with the proposed project:**

- |               |
|---------------|
| • Sandy Creek |
| •             |
| •             |
| •             |

**Please identify up to three available documents which contain information specific to the proposed project. Include conceptual plans, permits, drawings, and technical documents:**

- |   |
|---|
| • Sandy Creek Flood Control Project, J.H. Hansen Engineering, March 1986 (for the Kern County Water Agency) |
| • Sandy Creek Hydrology Study, September 2, 2005, Meyer Civil Engineering, Inc. (for City of Taft)          |
| • Kern IRWMP  |

Please identify federal, state, or local permits, which pertain to the proposed project and would need to be obtained or, if existing, would need to be amended:

• Grading permit
• Corp of Engineers
•

Please identify any existing projects or facilities, including existing water conveyance infrastructure, which would be affected, modified, or superseded as a result of implementing the proposed project:

•
•
•

Is the proposed project an element or phase of a regional or larger program?:	<input type="checkbox"/> Yes	<input checked="" type="checkbox"/> No
If yes, please identify the program:		
Design life of the project:		
Proposed Construction/Implementation Start Date:	January 2017	
Proposed Construction/Implementation Completion Date:	October 2017	
Ready for Construction Bid:	<input type="checkbox"/> Yes	<input type="checkbox"/> No <input checked="" type="checkbox"/> N/A

Item	Status (e.g., not initiated, in process, complete)	Date (mm/dd/yyyy)
Conceptual Plans	complete	09/02/2005
Land Acquisition/ Easements	Not initiated	
Preliminary Plans	Not initiated	
CEQA/NEPA	Not initiated	
Permits	Not initiated	
Construction Drawings	Not initiated	

For projects ready for construction or implementation, including projects which do not include construction, briefly describe the project's readiness to proceed.

**Project Readiness (Narrative)**

There are conceptual design plans currently in place. Final design and construction will commence once funding is available.

Include any local or state board actions, code changes, or legislation needed in order to proceed with the project.

**Local or State Board Actions, Code Changes, or Legislation**

**Please describe the dominant existing land use type for the proposed project location.**

Oil field, rural, residential

**Please describe the dominant existing land use type for areas upstream and downstream of the proposed project location**

Upstream:	Oil field, rural, residential
Downstream:	Residential, rural, Ag

## Part 4. Project Benefits

Please provide a one or two paragraph description of the benefit(s) that the project will address. Benefit Categories, shown below, are referenced from the [Storm Water Resource Plan Guidelines](#), Page 31, Table 4. Each project should address at least two or more Main Benefits and as many Additional Benefits as feasible. Information you provide will be used to evaluate the project for State grant funding.

Storm Water Management Benefits		
Benefit Category	Main Benefit	Additional Benefit
<b>Water Quality</b> (while contributing to compliance with applicable permit and/or TMDL requirements)	<ul style="list-style-type: none"> <li>Increased filtration and/or treatment of run-off</li> </ul>	<ul style="list-style-type: none"> <li>Non-point source pollution control</li> <li>Reestablished natural water drainage and treatment</li> </ul>
<b>Water Supply</b> (through groundwater management and/or run-off capture and use)	<ul style="list-style-type: none"> <li>Water supply reliability</li> <li>Conjunctive use</li> </ul>	<ul style="list-style-type: none"> <li>Water conservation</li> </ul>
<b>Flood Management</b>	<ul style="list-style-type: none"> <li>Decreased flood risk by reducing run-off rate and/or volume</li> </ul>	<ul style="list-style-type: none"> <li>Reduced sanitary sewer overflows</li> </ul>
<b>Environmental and Habitat Enhancement</b>	<ul style="list-style-type: none"> <li>Environmental and habitat protection and improvement, including;                             <ul style="list-style-type: none"> <li>wetland enhancement/creation;</li> <li>riparian enhancement; and/or</li> <li>instream flow improvement</li> </ul> </li> <li>Increased urban green space</li> </ul>	<ul style="list-style-type: none"> <li>Reduced energy use, greenhouse gas emissions, or provides a carbon sink</li> <li>Reestablishment of the natural hydrograph</li> <li>Water temperature improvements</li> </ul>
<b>Community Stewardship</b>	<ul style="list-style-type: none"> <li>Employment opportunities provided</li> <li>Public Education</li> </ul>	<ul style="list-style-type: none"> <li>Community involvement</li> <li>Enhance and/or create recreational and public use areas</li> </ul>

Source: Page 31, Table 4, Storm Water Resource Plan Guidelines, State Water Resources Control Board

Please provide the following **PROJECT BENEFIT** information for all applicable components of the proposed project. Benefit categories include:

- **Water Quality**
- **Water Supply**
- **Flood Management**
- **Environmental and Habitat Enhancement**
- **Community Stewardship**

If the project benefits a disadvantaged community (DAC) describe the specific benefits to that community. Estimate the percentage of the project benefits to the DAC.

Please supply all information relevant to the proposed project. The information you provide will be used to evaluate the project for State grant funding. **Attach additional sheets if necessary.**

## Water Quality Benefits

1. Describe how the proposed project will improve source control for both pollution and dry weather runoff volume, onsite and local infiltration, and use of storm water and dry weather runoff.
2. Describe design criteria and best management practices to prevent storm water and dry weather runoff pollution and increase effective storm water and dry weather runoff management for new and upgraded infrastructure and residential, commercial, industrial, and public development
3. Describe how the proposed project complies with or is consistent with an applicable NPDES permit. The analysis should simulate the proposed watershed-based outcomes using modeling, calculations, pollutant mass balances, water volume balances, and/or other methods of analysis. Describe how the proposed project will contribute to the preservation, restoration, or enhancement of watershed processes (as described in Guidelines section VI.C.2.a)
4. Describe the water quality monitoring and data acquisition that will be implemented in conjunction with the proposed project. Describe the a) mechanisms by which data will be managed and stored; b) how data will be accessed by stakeholders and the public; c) how existing water quality and water quality monitoring will be assessed; d) frequency at which data will be updated; and e) how data gaps will be identified.

### Water Quality Benefits (Narrative)

<p><b>The proposed detention basin at Midoil Road will provide some increase in infiltration to groundwater. The proposed channel work, removal of non-native plants and construction of grade control structures will help with downstream sedimentation issues.</b></p>	
Pollutant TMDL reduction (Volume per day) and (mass /unit volume) of most probable number of bacteria or indicator organisms (mpn/mL):	Sandy Creek does not have a TMDL
Increase in infiltration rate above existing condition:	Limited groundwater increase from detention basin
Non-point source pollution control:	sedimentation
Does project affect an Existing NPDES Permit? If applicable, describe the need for a new NPDES Permit:	The project will not affect an existing NPDES permit

## Water Supply Benefits

1. Describe how the proposed project captures and reuses storm water and dry weather runoff for groundwater recharge or storage for beneficial use.
2. Please provide detailed information to quantify how the proposed project will reduce existing potable water demand.
3. Describe the water supply monitoring and data acquisition that will be implemented in conjunction with the proposed project. Describe the a) mechanisms by which data will be managed and stored; b) how data will be accessed by stakeholders and the public; c) how existing water quality and water quality monitoring will be assessed; d) frequency at which data will be updated; and e) how data gaps will be identified

### Water Supply Benefits (Narrative)

<p><b>There is no specific storm water capture proposed. Just natural infiltration along Sandy Creek and at the detention basin located at Midoil Road.</b></p>
---

### Enhanced Water Supply or Demand Reduction Benefit Information

<b>Source of Increased Supply or Demand Reduction</b>	
<input checked="" type="checkbox"/> Groundwater <input type="checkbox"/> Recycled water <input type="checkbox"/> Transfer	<input type="checkbox"/> Groundwater treatment <input checked="" type="checkbox"/> Conservation/ water use efficiency <input type="checkbox"/> Other (describe):
<input checked="" type="checkbox"/> Increased surface water storage <input type="checkbox"/> Ocean desalination	
Type of enhanced supply or demand reduction:	Increased infiltration and groundwater recharge from the proposed detention basin
Annual Yield of Supply (acre-feet):	Not determined
<b>Availability by Water-Year Type (acre-feet per year)</b>	
Average Year:	<u>Not determined</u>
Dry Year:	<u>Not determined</u>
Wet Year:	<u>Not determined</u>
<b>Availability by Season (check all that apply):</b>	
<input checked="" type="checkbox"/> Summer <input checked="" type="checkbox"/> Fall <input checked="" type="checkbox"/> Spring <input checked="" type="checkbox"/> Winter	
<b>Does the project have the potential to displace demands on the Bay/Delta/Estuary?</b>	
<input checked="" type="checkbox"/> Yes <input type="checkbox"/> No <input type="checkbox"/> Not Sure	

## Flood Management Benefits

1. Describe how the proposed project will reestablish natural water drainage treatment and infiltration systems, or mimic natural system functions to the maximum extent feasible.
2. Describe how the proposed project will reduce flood risk by reducing runoff rate and/or volume.
3. If applicable, describe how the proposed project will reduce the risk of sanitary sewer overflows.

### Flood Management Benefits (Narrative)

The construction of the detention basin, shaping and armoring the stream banks to prevent additional erosion, and constructing a series of drop structures to slow the flow, reduce energy, will reduce the negative affects of erosion, degradation and aggradation.	
Maximum volume of temporary storage of storm water runoff (acre-feet):	187
Maximum increased conveyance capacity (cubic feet/second):	Not determined
Estimated area benefiting from flood damage reduction (acres):	600
Estimated level of flood protection resulting from project implementation (% annual probability of recurrence or 1-in-number of years recurrence):	100
Estimated annual value of flood damage reduction provided by project (\$/year):	unknown
Land required for project implementation (acres):	40

### For projects that include detention and groundwater recharge, please complete the following:

How many acres of land drain into this detention basin? (acres):	25000
Detention Basin area (acres):	10
Detention basin max. operational depth (ft.):	10
% of basin covered by wetlands:	N/A
Soil type:	Varies/sandy
If other than infiltration, identify method (e.g., injection) and recharge (acre-feet/year):	none
Estimated basin annual inflow (acre-feet/year):	2139 CFS 100-year storm
Estimated basin annual outflow (acre-feet/year):	848 CFS 100-year storm

## Environmental and Habitat Enhancement Benefits

Describe how the proposed project identifies opportunities to develop, restore, or enhance habitat and open space through storm water and dry weather runoff management, including wetlands, riverside habitats, parkways, and parks. Provide some type of quantitative measurement, which will show how the project benefits the environment and enhances the natural habitat.

### Environmental and Habitat Enhancement Benefits (Narrative)

The project is not designed to have any environmental or habitat enhancements.
--

Non-treatment wetland area (acres):	N/A
Treatment wetland area (acres):	N/A
Riparian habitat area (acres):	N/A
Non-developed open space area (acres):	N/A
Total Project area (acres):	N/A



## Community Stewardship Benefits

Describe how the project identifies opportunities to use existing publicly owned lands and easements, including, but not limited to parks, open space, community gardens, farm and agricultural preserves, school sites, and government office buildings and complexes, to capture, clean, store, and use storm water and dry weather runoff either onsite or offsite. Provide some type of quantitative measurement, which will show how the project benefits the community.

### Community Stewardship Benefits (Narrative)

--

**Multiple use/ recreation area (acres) – additionally, select the type of multiple use / recreation and associated acres by type:**

Single Sport Athletics:	N/A
Multiple Sport Athletics Acres:	N/A
Other Recreation Acres:	N/A
Pedestrian Trail Acres:	N/A
Equestrian Trail Acres:	N/A
Other Passive Activity:	N/A
Other Acres (describe):	N/A
Description:	N/A
<b>Total Project Area (acres):</b>	0

## Part 5. Project Cost Estimate

Project cost information is needed to assist in comparing benefits and cost. Additionally, knowledge of the project type and cost will assist in identifying funding sources for potential projects.

Please indicate the estimated costs of project implementation and associated funding source(s). These costs should include land purchase/easement, planning/design/engineering, construction/ implementation, environmental compliance, administration, and contingency.

<b>Approximate Total Cost:</b> (If project costs are variable, please include lower and upper range estimates.)	Phase 1--\$10,000,000 (total project \$25,000,000)
<b>Funding Source:</b> (If multiple sources, list each source and the percent or amount funded by each)	City of Taft Kern County general fund State and Federal Grants
<b>Maximum Funding Match from Implementing Agency:</b>	To be determined
<b>Funding Certainty &amp; Longevity:</b>	To be determined
<b>Operations &amp; Maintenance Cost:</b> (per year)	To be determined
<b>Operations &amp; Maintenance Funding Source(s)</b> (i.e., annual budget, grant, etc. If multiple sources, list each source and the percent or amount funded by each.)	To be determined
<b>Operations &amp; Maintenance Funding Certainty:</b> (i.e., already included in organization's budget, contingent upon grant, etc.)	To be determined

# Kern Storm Water Resource Plan

## Project Submittal Form

This form is to be electronically filled out and e-mailed to [LMarino@ppeng.com](mailto:LMarino@ppeng.com) by June 24, 2016.

Reference: [Storm Water Resource Plan Guidelines](#), December 15, 2015  
State Water Resources Control Board

### Part 1. Lead Implementing Agency/Organizational Information

Please provide the following information regarding the project sponsor and proposed project.

**Implementing Agency / Organization / Individual:**

Buena Vista Water Storage District

**Agency / Organization / Individual Address:**

P.O. Box 756  
Buttonwillow, CA 93206

**Possible Partnering Agencies:**

West Kern W.S.D., Rosedale Rio Bravo W.S.D., potentially other Kern IRWMP water districts.

**Name:**

Tim Ashlock

**Title:**

District Engineer

**Telephone:**

661-324-1101

**Fax:**

**Email:**

tim@bv2o.com

**Website:**

www.bv2o.com

**Project Name:**

The Palms Storm Water Recharge and Recovery Project

Either the latitude/longitude or a location description is required. To determine the latitude/longitude, use the closest address or intersection. If the project is linear, use the furthest upstream latitude/longitude.

**Project Latitude:**  **Project Longitude:**

<b>Location Description:</b>	Latitude/longitude is located at the approximate center of the proposed project recharge basin.
------------------------------	---

**Project Cooperating Agency(ies)/Organization(s)/Individual(s):**

•
•
•
•

**Project Status (e.g., new, ongoing, expansion, new phase):**

**Has the Project been submitted to IRWM Plan:**

Kern IRWMP  Poso Creek IRWMP  Not Submitted

**Does the project address any known environmental justice issues?**

Yes  No  Not Sure

**Is the project located within or adjacent to a disadvantaged community (DAC)? Refer to this [website](#).**

Within  Adjacent  No  Not Sure

**Does the project include DAC participation?**

Yes  No  Not Sure

If yes, please identify the contact person, group, or organization and describe the DAC's participation:

**What is the DAC's estimated population:**

Does the Implementing Agency own the land where the project is located? If no, describe ability to purchase land or if eminent domain is required:

Yes  No

## Part 2. Project Need

It is important to understand the need(s) or issue(s) that the proposed project will address and the benefits that it will provide. Information provided in this section defines the need(s) or issue(s) that the proposed project will address and will help to catalog existing need(s) or issue(s) in the planning area of the Kern Storm Water Resource Plan.

Please provide a 1-2 paragraph description of the need(s) or problem(s) that the proposed project will address. Discuss the benefits to water quality, water supply, flood management, environmental, and community benefits that the proposed project will bring. Discuss critical impacts or worsening conditions that will occur if the proposed project is not implemented.

### Project Need (Narrative)

Storm water captured by the proposed Project originates from uplands that form the watersheds of the lakes and reservoirs that will release water recharged by the Project. While flood releases would be expected to carry small sediment loads, the sediment loads may be substantial at the points where the storm water will be diverted into groundwater recharge facilities. Because the path of the storm water will not cross major urban or agricultural land uses, with the exception of sediment, constituent loadings will be stable over time.

The quantity of storm water to be captured by the Project will fluctuate depending on the frequency and intensity of precipitation events driving storm water into the Kern River and its tributaries. Average annual recharge through Project facilities is estimated to be approximately 20,000 AF/year.

Approximately 80 percent of the storm water captured and recharged by the Project will be recoverable, and therefore will have the potential to contribute to offsetting demands from other sources. Because BVWSD is a State Water Project contractor these offsets have the potential to reduce demands on the Delta.

Benefits associated with the Project include: increased water supply reliability, conjunctive use, water conservation, treatment of runoff, instream flow improvement, and reduced energy use and greenhouse gas emissions.

### Part 3. Project Description

A general description of the proposed project is needed. This section will provide information associated with the project concept and general project information. Much of the requested information may not be available for projects that are in the conceptual stages of development. An essential element of the Kern Storm Water Resource Plan consists of proposed projects. We appreciate and need your ideas.

Please provide a one or two paragraph description of the project including the general project concept, what will be constructed/implemented, how the constructed project will function, what technologies or methods will be used, as appropriate. For water quality projects, include a description of impacts to existing Total Maximum Daily Loads, NPDES permits, and/or waste discharge requirements.

#### Project Description (Narrative)

<p>The Project will cover approximately 1,160 acres and will include features needed to recharge captured storm water and facilities for recovery and treatment of stored storm water. Construction of the component will include 1) construction of recharge facilities, 2) installation of pumps in existing wells and approximately 4 miles of pipeline, 3) construction and equipping additional recovery wells with associated piping, and 4) water treatment facilities, if needed.</p> <p>Recharged storm water will flow to aquifers that are water supply sources for residents of Tupman, for the disadvantaged communities of Taft and Buttonwillow, and to replenish groundwater under the Tule Elk Reserve. Lands used for recharge have an established history of irrigated crop production and have been retired for two years in anticipation of development of the Project. While retirement of these lands from irrigated agriculture will eliminate deep percolation of irrigation water, recharge of storm water will greatly reduce the potential for leaching of nitrates, salts and other contaminants. Earthwork would include construction of low berms from surface soil that overlies shallow, highly permeable river-borne sand deposits. Topsoil used for construction of berms will no longer be exposed to leaching further reducing transport of contaminants to groundwater.</p>
---

**If applicable, list surface water bodies and groundwater basins associated with the proposed project:**

<ul style="list-style-type: none"> <li>• Kern River</li> </ul>
<ul style="list-style-type: none"> <li>• State Water Project</li> </ul>
<ul style="list-style-type: none"> <li>• Kern Sub Basin</li> </ul>
<ul style="list-style-type: none"> <li>•</li> </ul>

**Please identify up to three available documents which contain information specific to the proposed project. Include conceptual plans, permits, drawings, and technical documents:**

<ul style="list-style-type: none"> <li>• Initial Study/Mitigated Negative Declaration for Palms Groundwater Banking Project</li> </ul>
<ul style="list-style-type: none"> <li>• Geology and Hydrology Review of The Palms Groundwater Recharge and Recovery Project – Robert A. Crewdson, Ph.D.</li> </ul>
<ul style="list-style-type: none"> <li>•</li> </ul>

Please identify federal, state, or local permits, which pertain to the proposed project and would need to be obtained or, if existing, would need to be amended:

• SWPPP
• DWR License Agreement
• Indirect Source Review & Dust Control Plan

Please identify any existing projects or facilities, including existing water conveyance infrastructure, which would be affected, modified, or superseded as a result of implementing the proposed project:

• Project would rehabilitate and utilize abandoned groundwater wells
•
•

Is the proposed project an element or phase of a regional or larger program?:	<input checked="" type="checkbox"/> Yes <input type="checkbox"/> No
If yes, please identify the program:	<u>Buena Vista Groundwater Recharge and Recovery Program (GRRP)</u>
Design life of the project:	<u>50 years ±</u>
Proposed Construction/Implementation Start Date:	<u>2017</u>
Proposed Construction/Implementation Completion Date:	<u>2018</u>
Ready for Construction Bid:	<input type="checkbox"/> Yes <input checked="" type="checkbox"/> No <input type="checkbox"/> N/A

Item	Status (e.g., not initiated, in process, complete)	Date (mm/dd/yyyy)
Conceptual Plans	<b>Complete</b>	8/2015
Land Acquisition/ Easements	<b>Complete</b>	1120 ac complete 40 ac pending winter 2016
Preliminary Plans	<b>In Process</b>	
CEQA/NEPA	<b>Recharge Facilities CEQA completed, Recovery facilities CEQA in process</b>	1/2016 Winter 2017
Permits	<b>Not initiated</b>	
Construction Drawings	<b>Not initiated</b>	

For projects ready for construction or implementation, including projects which do not include construction, briefly describe the project's readiness to proceed.

**Project Readiness (Narrative)**

**BVWSD has adopted an Initial Study/Mitigated Negative Declaration for the Project. Construction activity for the recharge facilities is scheduled to begin in the winter of 2017 and be completed within 6 months. Construction of recovery facilities will follow and be completed by the fall of 2018.**

Include any local or state board actions, code changes, or legislation needed in order to proceed with the project.

**Local or State Board Actions, Code Changes, or Legislation**

N/A

**Please describe the dominant existing land use type for the proposed project location.**

Fallow land

**Please describe the dominant existing land use type for areas upstream and downstream of the proposed project location**

Upstream:	Kern River channel
Downstream:	N/A



## Part 4. Project Benefits

Please provide a one or two paragraph description of the benefit(s) that the project will address. Benefit Categories, shown below, are referenced from the [Storm Water Resource Plan Guidelines](#), Page 31, Table 4. Each project should address at least two or more Main Benefits and as many Additional Benefits as feasible. Information you provide will be used to evaluate the project for State grant funding.

Storm Water Management Benefits		
Benefit Category	Main Benefit	Additional Benefit
<b>Water Quality</b> (while contributing to compliance with applicable permit and/or TMDL requirements)	<ul style="list-style-type: none"> <li>Increased filtration and/or treatment of run-off</li> </ul>	<ul style="list-style-type: none"> <li>Non-point source pollution control</li> <li>Reestablished natural water drainage and treatment</li> </ul>
<b>Water Supply</b> (through groundwater management and/or run-off capture and use)	<ul style="list-style-type: none"> <li>Water supply reliability</li> <li>Conjunctive use</li> </ul>	<ul style="list-style-type: none"> <li>Water conservation</li> </ul>
<b>Flood Management</b>	<ul style="list-style-type: none"> <li>Decreased flood risk by reducing run-off rate and/or volume</li> </ul>	<ul style="list-style-type: none"> <li>Reduced sanitary sewer overflows</li> </ul>
<b>Environmental and Habitat Enhancement</b>	<ul style="list-style-type: none"> <li>Environmental and habitat protection and improvement, including;                             <ul style="list-style-type: none"> <li>wetland enhancement/creation;</li> <li>riparian enhancement; and/or</li> <li>instream flow improvement</li> </ul> </li> <li>Increased urban green space</li> </ul>	<ul style="list-style-type: none"> <li>Reduced energy use, greenhouse gas emissions, or provides a carbon sink</li> <li>Reestablishment of the natural hydrograph</li> <li>Water temperature improvements</li> </ul>
<b>Community Stewardship</b>	<ul style="list-style-type: none"> <li>Employment opportunities provided</li> <li>Public Education</li> </ul>	<ul style="list-style-type: none"> <li>Community involvement</li> <li>Enhance and/or create recreational and public use areas</li> </ul>

Source: Page 31, Table 4, Storm Water Resource Plan Guidelines, State Water Resources Control Board

Please provide the following **PROJECT BENEFIT** information for all applicable components of the proposed project. Benefit categories include:

- **Water Quality**
- **Water Supply**
- **Flood Management**
- **Environmental and Habitat Enhancement**
- **Community Stewardship**

If the project benefits a disadvantaged community (DAC) describe the specific benefits to that community. Estimate the percentage of the project benefits to the DAC.

Please supply all information relevant to the proposed project. The information you provide will be used to evaluate the project for State grant funding. **Attach additional sheets if necessary.**

## Water Quality Benefits

1. Describe how the proposed project will improve source control for both pollution and dry weather runoff volume, onsite and local infiltration, and use of storm water and dry weather runoff.
2. Describe design criteria and best management practices to prevent storm water and dry weather runoff pollution and increase effective storm water and dry weather runoff management for new and upgraded infrastructure and residential, commercial, industrial, and public development
3. Describe how the proposed project complies with or is consistent with an applicable NPDES permit. The analysis should simulate the proposed watershed-based outcomes using modeling, calculations, pollutant mass balances, water volume balances, and/or other methods of analysis. Describe how the proposed project will contribute to the preservation, restoration, or enhancement of watershed processes (as described in Guidelines section VI.C.2.a)
4. Describe the water quality monitoring and data acquisition that will be implemented in conjunction with the proposed project. Describe the a) mechanisms by which data will be managed and stored; b) how data will be accessed by stakeholders and the public; c) how existing water quality and water quality monitoring will be assessed; d) frequency at which data will be updated; and e) how data gaps will be identified.

### Water Quality Benefits (Narrative)

<p>A portion of the captured storm water recharged in the Project will be treated to Title 22 standards, if treatment is needed to enable recovered water to be conveyed in the California Aqueduct to urban agencies in Southern California. All storm water recharged by the Project will pass through sediment basins and be filtered as it percolates through the soil profile.</p> <p>Recharge of storm water will also reduce the concentration of salts, nitrate, and arsenic in the underlying groundwater. Furthermore, BVWSD's western boundary is formed by the Coastal Range that is derived from marine and lacustrine deposits that tend to have marginal to poor quality groundwater (high salinity). The Project will increase groundwater levels in the southern portion of BVWSD, reducing the head gradient separating the good quality groundwater located on the basin floor and the poorer groundwater to the west.</p>	
Pollutant TMDL reduction (Volume per day) and (mass /unit volume) of most probable number of bacteria or indicator organisms (mpn/mL):	
Increase in infiltration rate above existing condition:	
Non-point source pollution control:	Sedimentation load reduced through sedimentation basins, filtration occurs through soil profile.
Does project affect an Existing NPDES Permit? If applicable, describe the need for a new NPDES Permit:	

## Water Supply Benefits

1. Describe how the proposed project captures and reuses storm water and dry weather runoff for groundwater recharge or storage for beneficial use.
2. Please provide detailed information to quantify how the proposed project will reduce existing potable water demand.
3. Describe the water supply monitoring and data acquisition that will be implemented in conjunction with the proposed project. Describe the a) mechanisms by which data will be managed and stored; b) how data will be accessed by stakeholders and the public; c) how existing water quality and water quality monitoring will be assessed; d) frequency at which data will be updated; and e) how data gaps will be identified

### Water Supply Benefits (Narrative)

**The Project will increase water supply by storing captured storm water in the local groundwater aquifer. Groundwater recharge is particularly timely in Kern County where the extended drought has depleted aquifers that are relied upon by users throughout the region. In addition, both components support conjunctive use by capturing storm water during the limited periods when it is available for aquifer replenishment and that, once stored, can be relied upon during dry periods. Water is conserved by recharging captured storm water in areas where stored water is readily accessible.**

### Enhanced Water Supply or Demand Reduction Benefit Information

<b>Source of Increased Supply or Demand Reduction</b>	
<input checked="" type="checkbox"/> Groundwater	<input type="checkbox"/> Groundwater treatment
<input type="checkbox"/> Recycled water	<input type="checkbox"/> Conservation/ water use efficiency
<input type="checkbox"/> Transfer	<input type="checkbox"/> Other (describe):
<input type="checkbox"/> Increased surface water storage	<input type="checkbox"/> Ocean desalination
Type of enhanced supply or demand reduction:	Groundwater
Annual Yield of Supply (acre-feet):	20,000
<b>Availability by Water-Year Type (acre-feet per year)</b>	
Average Year:	20,000 AF enhanced supply
Dry Year:	20,000 AF enhanced supply
Wet Year:	20,000 AF enhanced supply
<b>Availability by Season (check all that apply):</b>	
<input checked="" type="checkbox"/> Summer	<input checked="" type="checkbox"/> Fall
<input checked="" type="checkbox"/> Spring	<input checked="" type="checkbox"/> Winter
<b>Does the project have the potential to reduce dependence on the Sacramento San Joaquin Bay-Delta?</b>	
<input checked="" type="checkbox"/> Yes	<input type="checkbox"/> No
<input type="checkbox"/> Not Sure	

## Flood Management Benefits

1. Describe how the proposed project will reestablish natural water drainage treatment and infiltration systems, or mimic natural system functions to the maximum extent feasible.
2. Describe how the proposed project will reduce flood risk by reducing runoff rate and/or volume.
3. If applicable, describe how the proposed project will reduce the risk of sanitary sewer overflows.

### Flood Management Benefits (Narrative)

<p>Low lying developed areas in the San Joaquin Valley periodically are inundated by flood waters. The Tulare Lake area in particular is the recipient of floodwaters from the Kings, Kaweah, Tulare, Kern Rivers, and a number of smaller streams. A portion of the water recharged in the Project otherwise would have contributed to flooding of low-lying improved lands in Kern County near the Kern River Flood Channel, Kings County (Tulare Lake Bed), and other areas further North (adjacent to the San Joaquin River and Delta). However, the amounts are difficult to quantify because of the complexity of floodwater pathways, impact location, and degree of impacts to developed lands.</p>	
Description facilities protected:	
Maximum volume of temporary storage of storm water runoff (acre-feet):	
Maximum increased conveyance capacity (cubic feet/second):	
Estimated area benefiting from flood damage reduction (acres):	
Estimated level of flood protection resulting from project implementation (% annual probability of recurrence or 1-in-number of years recurrence):	
Estimated annual value of flood damage reduction provided by project (\$/year):	
Land required for project implementation (acres):	

### For projects that include detention and groundwater recharge, please complete the following:

How many acres of land drain into this detention basin? (acres):	0
Detention Basin area (acres):	1,160
Detention basin max. operational depth (ft.):	4 ft
% of basin covered by wetlands:	90%
Soil type:	Sandy
If other than infiltration, identify method (e.g., injection) and recharge (acre-feet/year):	7.6 AF/ac-month
Estimated basin annual inflow (acre-feet/year):	40,000-70,000 AF/yr (3 out of 10 yrs)
Estimated basin annual outflow (acre-feet/year):	0

## Environmental and Habitat Enhancement Benefits

Describe how the proposed project identifies opportunities to develop, restore, or enhance habitat and open space through storm water and dry weather runoff management, including wetlands, riverside habitats, parkways, and parks. Provide some type of quantitative measurement, which will show how the project benefits the environment and enhances the natural habitat.

### Environmental and Habitat Enhancement Benefits (Narrative)

Using captured storm water to maintain groundwater levels in Kern County will lower pumping lifts and consequently reduce energy use and greenhouse gas emissions. The Project will also increase base flow in regional streams, benefiting local habitats in stream channels and wetlands.

Non-treatment wetland area (acres):	
Treatment wetland area (acres):	
Riparian habitat area (acres):	
Non-developed open space area (acres):	
Total Project area (acres):	<u>1,160</u>

## Community Stewardship Benefits

Describe how the project identifies opportunities to use existing publicly owned lands and easements, including, but not limited to parks, open space, community gardens, farm and agricultural preserves, school sites, and government office buildings and complexes, to capture, clean, store, and use storm water and dry weather runoff either onsite or offsite. Provide some type of quantitative measurement, which will show how the project benefits the community.

### Community Stewardship Benefits (Narrative)

--

**Multiple use/ recreation area (acres) – additionally, select the type of multiple use / recreation and associated acres by type:**

Single Sport Athletics:	
Multiple Sport Athletics Acres:	
Other Recreation Acres:	
Pedestrian Trail Acres:	
Equestrian Trail Acres:	
Other Passive Activity:	
Other Acres (describe):	
Description:	
<b>Total Project Area (acres):</b>	

## Part 5. Project Cost Estimate

Project cost information is needed to assist in comparing benefits and cost. Additionally, knowledge of the project type and cost will assist in identifying funding sources for potential projects.

Please indicate the estimated costs of project implementation and associated funding source(s). These costs should include land purchase/easement, planning/design/engineering, construction/ implementation, environmental compliance, administration, and contingency.

<b>Approximate Total Cost:</b> (If project costs are variable, please include lower and upper range estimates.)	\$10,000,000
<b>Funding Source:</b> (If multiple sources, list each source and the percent or amount funded by each)	SWGP Implementation Funding
<b>Maximum Funding Match from Implementing Agency:</b>	BVWSD to contribute 50% funding match.
<b>Funding Certainty &amp; Longevity:</b>	SWGP Application submitted.
<b>Operations &amp; Maintenance Cost:</b> (per year)	\$125,000
<b>Operations &amp; Maintenance Funding Source(s)</b> (i.e., annual budget, grant, etc. If multiple sources, list each source and the percent or amount funded by each.)	Annual budget.
<b>Operations &amp; Maintenance Funding Certainty:</b> (i.e., already included in organization's budget, contingent upon grant, etc.)	50% in current budget, balance contingent upon construction of project.

# Kern Storm Water Resource Plan

## Project Submittal Form

This form is to be electronically filled out and e-mailed to [LMarino@ppeng.com](mailto:LMarino@ppeng.com) by June 24, 2016.

Reference: [Storm Water Resource Plan Guidelines](#), December 15, 2015  
State Water Resources Control Board

### Part 1. Lead Implementing Agency/Organizational Information

Please provide the following information regarding the project sponsor and proposed project.

**Implementing Agency / Organization / Individual:**

Rosedale-Rio Bravo Water Storage District

**Agency / Organization / Individual Address:**

849 Allen Road  
P.O. Box 20820  
Bakersfield, CA 93390

**Possible Partnering Agencies:**

None

**Name:**

Dan Bartel

**Title:**

Assistant General Manager-Engineer

**Telephone:**

661-589-6045

**Fax:**

661-589-1867

**Email:**

[dbartel@rrbwsd.com](mailto:dbartel@rrbwsd.com)

**Website:**

[www.rrbwsd.com](http://www.rrbwsd.com)

**Project Name:**

Stockdale East Groundwater Recharge Project



Either the latitude/longitude or a location description is required. To determine the latitude/longitude, use the closest address or intersection. If the project is linear, use the furthest upstream latitude/longitude.

**Project Latitude:**  **Project Longitude:**

<b>Location Description:</b>	West of Bakersfield, immediately east of the intersection of Enos Lane (Highway 43) and Stockdale Highway.
------------------------------	--

**Project Cooperating Agency(ies)/Organization(s)/Individual(s):**

- |   |
|---|
| • |
| • |
| • |
| • |

**Project Status (e.g., new, ongoing, expansion, new phase):**

**Has the Project been submitted to IRWM Plan:**

Kern IRWMP  Poso Creek IRWMP  Not Submitted

**Does the project address any known environmental justice issues?**

Yes  No  Not Sure

**Is the project located within or adjacent to a disadvantaged community (DAC)? Refer to this [website](#).**

Within  Adjacent  No  Not Sure

**Does the project include DAC participation?**

Yes  No  Not Sure

If yes, please identify the contact person, group, or organization and describe the DAC's participation:

**What is the DAC's estimated population?**

Does the Implementing Agency own the land where the project is located? If no, describe ability to purchase land or if eminent domain is required:

Yes  No

## Part 2. Project Need

It is important to understand the need(s) or issue(s) that the proposed project will address and the benefits that it will provide. Information provided in this section defines the need(s) or issue(s) that the proposed project will address and will help to catalog existing need(s) or issue(s) in the planning area of the Kern Storm Water Resource Plan.

Please provide a 1-2 paragraph description of the need(s) or problem(s) that the proposed project will address. Discuss the benefits to water quality, water supply, flood management, environmental, and community benefits that the proposed project will bring. Discuss critical impacts or worsening conditions that will occur if the proposed project is not implemented.

### Project Need (Narrative)

The Stockdale East Groundwater Recharge Project is designed to improve overall District system efficiency by increasing the District's ability to intercept high flow surface runoff for storage within the Kern Fan area groundwater basin.

The stored groundwater as a direct result of the Project will provide additional water to:

1. Support District water-users (agricultural, municipal, and industrial).
2. Provide enhanced protection against prolonged drought and climatic changes.
3. Reduce groundwater pumping lifts and resulting energy savings.
4. Potentially support third-party banking and transfer partners.
5. Provide intermittent wetlands for wildlife environmental benefits.

### Part 3. Project Description

A general description of the proposed project is needed. This section will provide information associated with the project concept and general project information. Much of the requested information may not be available for projects that are in the conceptual stages of development. An essential element of the Kern Storm Water Resource Plan consists of proposed projects. We appreciate and need your ideas.

Please provide a one or two paragraph description of the project including the general project concept, what will be constructed/implemented, how the constructed project will function, what technologies or methods will be used, as appropriate. For water quality projects, include a description of impacts to existing Total Maximum Daily Loads, NPDES permits, and/or waste discharge requirements.

#### Project Description (Narrative)

The benefits of the project described in the Project Need section will be accomplished through two project components:

1. Stockdale East Recharge Ponds: construction approximately 200 acres of recharge ponds via the placement of 203,000 CY of compacted levees that are approximately 2-5 feet in height. Upwards of 19,000 acre-feet per year (AFY) (typically 3 years in 10) of recharge water will be conveyed from pond to pond via 10 inter-basin check structures.
2. Central Intake Pumping Plant - RRBWSD is preparing to construct a Central Intake Pipeline Facility as part of its Emergency Drought Relief Project. The overall project includes installing pipelines, which range in size from 48-inch to 72-inch diameter that will allow RRBWSD the ability to network various groundwater recharge and conveyance facilities in order to maximize opportunities to store in the groundwater basin available, Stormwater runoff during wet years. In order to deliver local, state and federal water for recharge purposes to the Stockdale East property and other existing recharge projects (Superior Recharge Ponds and Goose Lake Slough), 4 low lift pumps (total of 140 cfs capacity) along with high efficiency motors, variable frequency drives (VFDs), SCADA control units, flow meters, and discharge piping must be added to the Pumping Plant. Upwards of 19,000 AFY of recharge water will be conveyed to the Stockdale East Recharge Ponds and upwards of 30,000 AFY could be conveyed to the Superior Recharge Ponds and Goose Lake Slough (typically 3 years in 10), 10,000 AFY of which would be new recharge and 20,000 AFY would be water better managed via this preferred route. A detailed analysis is needed to refine the portions of Stormwater that is captured as available surface water during the wet years; this project develops the capability to move Stormwater into the recharge basins.

**If applicable, list surface water bodies and groundwater basins associated with the proposed project:**

• Kern River
• California Aqueduct
• Friant-Kern Canal
•

**Please identify up to three available documents which contain information specific to the proposed project. Include conceptual plans, permits, drawings, and technical documents:**

• 2016 WaterSMART Water and Energy Efficiency Grant Application
•
•

Please identify federal, state, or local permits, which pertain to the proposed project and would need to be obtained or, if existing, would need to be amended:

• None
•
•

Please identify any existing projects or facilities, including existing water conveyance infrastructure, which would be affected, modified, or superseded as a result of implementing the proposed project:

• A Cross Valley Canal intake would be constructed
•
•

Is the proposed project an element or phase of a regional or larger program?	<input checked="" type="checkbox"/> Yes <input type="checkbox"/> No
If yes, please identify the program:	Kern IRWM
Design life of the project:	<u>50</u>
Proposed Construction/Implementation Start Date:	
Proposed Construction/Implementation Completion Date:	
Ready for Construction Bid:	<input type="checkbox"/> Yes <input checked="" type="checkbox"/> No <input type="checkbox"/> N/A

Item	Status (e.g., not initiated, in process, complete)	Date (mm/dd/yyyy)
Conceptual Plans	Complete	
Land Acquisition/ Easements	In process	
Preliminary Plans	Complete	
CEQA/NEPA	In process	
Permits	Complete	
Construction Drawings	In process	

For projects ready for construction or implementation, including projects which do not include construction, briefly describe the project's readiness to proceed.

**Project Readiness (Narrative)**

The Project is in design stage with 100% design drawing to be completed in 2016. The Project is intended to move into construction towards the end of 2016 or into 2017. The environmental documentation and land easement are in progress.

Include any local or state board actions, code changes, or legislation needed in order to proceed with the project.

**Local or State Board Actions, Code Changes, or Legislation**

RRBWSO Board of Directors

**Please describe the dominant existing land use type for the proposed project location.**

Idle

**Please describe the dominant existing land use type for areas upstream and downstream of the proposed project location**

Upstream:	Agriculture
Downstream:	Agriculture

## Part 4. Project Benefits

Please provide a one or two paragraph description of the benefit(s) that the project will address. Benefit Categories, shown below, are referenced from the [Storm Water Resource Plan Guidelines](#), Page 31, Table 4. Each project should address at least two or more Main Benefits and as many Additional Benefits as feasible. Information you provide will be used to evaluate the project for State grant funding.

Storm Water Management Benefits		
Benefit Category	Main Benefit	Additional Benefit
<b>Water Quality</b> (while contributing to compliance with applicable permit and/or TMDL requirements)	<ul style="list-style-type: none"> <li>Increased filtration and/or treatment of run-off</li> </ul>	<ul style="list-style-type: none"> <li>Non-point source pollution control</li> <li>Reestablished natural water drainage and treatment</li> </ul>
<b>Water Supply</b> (through groundwater management and/or run-off capture and use)	<ul style="list-style-type: none"> <li><b>Water supply reliability</b></li> <li><b>Conjunctive use</b></li> </ul>	<ul style="list-style-type: none"> <li>Water conservation</li> </ul>
<b>Flood Management</b>	<ul style="list-style-type: none"> <li><b>Decreased flood risk by reducing run-off rate and/or volume</b></li> </ul>	<ul style="list-style-type: none"> <li>Reduced sanitary sewer overflows</li> </ul>
<b>Environmental and Habitat Enhancement</b>	<ul style="list-style-type: none"> <li>Environmental and habitat protection and improvement, including;                             <ul style="list-style-type: none"> <li>wetland enhancement/creation;</li> <li>riparian enhancement; and/or</li> <li>instream flow improvement</li> </ul> </li> <li>Increased urban green space</li> </ul>	<ul style="list-style-type: none"> <li>Reduced energy use, greenhouse gas emissions, or provides a carbon sink</li> <li>Reestablishment of the natural hydrograph</li> <li>Water temperature improvements</li> </ul>
<b>Community Stewardship</b>	<ul style="list-style-type: none"> <li>Employment opportunities provided</li> <li>Public Education</li> </ul>	<ul style="list-style-type: none"> <li>Community involvement</li> <li>Enhance and/or create recreational and public use areas</li> </ul>

Source: Page 31, Table 4, Storm Water Resource Plan Guidelines, State Water Resources Control Board

Please provide the following **PROJECT BENEFIT** information for all applicable components of the proposed project. Benefit categories include:

- **Water Quality**
- **Water Supply**
- **Flood Management**
- **Environmental and Habitat Enhancement**
- **Community Stewardship**

If the project benefits a disadvantaged community (DAC) describe the specific benefits to that community. Estimate the percentage of the project benefits to the DAC.

Please supply all information relevant to the proposed project. The information you provide will be used to evaluate the project for State grant funding. **Attach additional sheets if necessary.**

## Water Quality Benefits

1. Describe how the proposed project will improve source control for both pollution and dry weather runoff volume, onsite and local infiltration, and use of storm water and dry weather runoff.
2. Describe design criteria and best management practices to prevent storm water and dry weather runoff pollution and increase effective storm water and dry weather runoff management for new and upgraded infrastructure and residential, commercial, industrial, and public development
3. Describe how the proposed project complies with or is consistent with an applicable NPDES permit. The analysis should simulate the proposed watershed-based outcomes using modeling, calculations, pollutant mass balances, water volume balances, and/or other methods of analysis. Describe how the proposed project will contribute to the preservation, restoration, or enhancement of watershed processes (as described in Guidelines section VI.C.2.a)
4. Describe the water quality monitoring and data acquisition that will be implemented in conjunction with the proposed project. Describe the a) mechanisms by which data will be managed and stored; b) how data will be accessed by stakeholders and the public; c) how existing water quality and water quality monitoring will be assessed; d) frequency at which data will be updated; and e) how data gaps will be identified.

### Water Quality Benefits (Narrative)

<p>Providing a connection for Stormwater that is delivered as surface water to recharge sites increases infiltration of surface water to storage in groundwater and enhances quality of the basin. The surface water available during wet periods is delivered to spreading facility for direct recharge. The use of direct spreading facility as the recharge mechanism avoids adding nutrients and transporting constituents used in growing crops.</p>	
<p>Pollutant TMDL reduction (Volume per day) and (mass /unit volume) of most probable number of bacteria or indicator organisms (mpn/mL):</p>	<p><u>Unknown</u></p>
<p>Increase in infiltration rate above existing condition:</p>	<p><u>Yes, delivers Stormwater to recharge facility</u></p>
<p>Non-point source pollution control:</p>	<p><u>Unknown</u></p>
<p>Does project affect an Existing NPDES Permit? If applicable, describe the need for a new NPDES Permit:</p>	<p><u>Unknown</u></p>

## Water Supply Benefits

1. Describe how the proposed project captures and reuses storm water and dry weather runoff for groundwater recharge or storage for beneficial use.
2. Please provide detailed information to quantify how the proposed project will reduce existing potable water demand.
3. Describe the water supply monitoring and data acquisition that will be implemented in conjunction with the proposed project. Describe the a) mechanisms by which data will be managed and stored; b) how data will be accessed by stakeholders and the public; c) how existing water quality and water quality monitoring will be assessed; d) frequency at which data will be updated; and e) how data gaps will be identified

### Water Supply Benefits (Narrative)

The project will save a total of **9,500 AFY** by conserving groundwater directly as a result of the recharge of wet year water by this project.

Hydrology shows that the region experiences wet years sufficient to provide supplies to the project about every three in ten years. That would result in an average of additional **5,700 AFY** (0.3 x 19,000 AF) stored groundwater. Approximately 50 cfs of the Central Intake Pumping Plant – Phase 2 would be dedicated to serving this site. Given this evaluation is for a wet year, a more detailed evaluation of Stormwater available during a wet year is needed to refine the average annual amount of water supply benefit.

An additional 90 cfs would be included to offer capacity to deliver state and federal water to existing recharge areas located approximately 1.5 miles north of the site (Superior Basins). This would give added access to recharge supplies and potentially add up to 10,000 AF into the groundwater basin during each wet year. Using the same wet-year probability, this would result in an average of **3,000 AFY** (0.3 x 10,000 AF) of additional stored groundwater. An additional **800 AFY** of water is conserved due to the retiring of the required 229 acres of land (229 acres x 3.5 AF/acre). Therefore, a total of **9,500 AFY** would be conserved as a direct result of the project and the estimate of the portion directly related to Stormwater needs refinement.

### Enhanced Water Supply or Demand Reduction Benefit Information

Source of Increased Supply or Demand Reduction	
<input checked="" type="checkbox"/> Groundwater	<input type="checkbox"/> Groundwater treatment
<input type="checkbox"/> Recycled water	<input checked="" type="checkbox"/> Conservation/ water use efficiency
<input type="checkbox"/> Transfer	<input type="checkbox"/> Other (describe):
<input checked="" type="checkbox"/> Increased surface water storage	<input type="checkbox"/> Ocean desalination
Type of enhanced supply or demand reduction:	Flood water will be used to recharge groundwater
Annual Yield of Supply (acre-feet):	9,500 AFY
Availability by Water-Year Type (acre-feet per year)	
Average Year:	<u>9,500 AFY = [(19,000 AF plus 10,000 AF)*(3 wet years / 10 years) plus 800 AFY]</u>
Dry Year:	<u>800 AF</u>
Wet Year:	<u>29,800 AF = 19,000 AF plus 10,000 AF plus 800 AF</u>
<b>Availability by Season (check all that apply):</b>	



<input type="checkbox"/> Summer	<input checked="" type="checkbox"/> Fall	<input checked="" type="checkbox"/> Spring	<input checked="" type="checkbox"/> Winter
<b>Does the project have the potential to reduce dependence on the Bay/Delta/Estuary?</b>			
<input checked="" type="checkbox"/> Yes	<input type="checkbox"/> No	<input type="checkbox"/> Not Sure	

**Flood Management Benefits**

1. Describe how the proposed project will reestablish natural water drainage treatment and infiltration systems, or mimic natural system functions to the maximum extent feasible.
2. Describe how the proposed project will reduce flood risk by reducing runoff rate and/or volume.
3. If applicable, describe how the proposed project will reduce the risk of sanitary sewer overflows.

**Flood Management Benefits (Narrative)**

The Project provides a flood management benefit inasmuch as the water diverted and stored will not contribute to increased downstream flows and flood risks from where the water is diverted.	
Description facilities protected:	Regional Conveyance Facilities within the Basin
Maximum volume of temporary storage of storm water runoff (acre-feet):	19,000
Maximum increased conveyance capacity (cubic feet/second):	140
Estimated area benefiting from flood damage reduction (acres):	Unknown
Estimated level of flood protection resulting from project implementation (% annual probability of recurrence or 1-in-number of years recurrence):	Unknown
Estimated annual value of flood damage reduction provided by project (\$/year):	Unknown
Land required for project implementation (acres):	229

**For projects that include detention and groundwater recharge, please complete the following:**

How many acres of land drain into this detention basin? (acres):	2,688 [Estimated in local area; surface water diverted to site from regional conveyance facility]
Detention Basin area (acres):	200
Detention basin max. operational depth (ft.):	5
% of basin covered by wetlands:	0
Soil type:	
If other than infiltration, identify method (e.g., injection) and recharge (acre-feet/year):	N/A
Estimated basin annual inflow (acre-feet/year):	8,700
Estimated basin annual outflow (acre-feet/year):	N/A

## Environmental and Habitat Enhancement Benefits

Describe how the proposed project identifies opportunities to develop, restore, or enhance habitat and open space through storm water and dry weather runoff management, including wetlands, riverside habitats, parkways, and parks. Provide some type of quantitative measurement, which will show how the project benefits the environment and enhances the natural habitat.

### Environmental and Habitat Enhancement Benefits (Narrative)

Like all spreading basins, the Project will provide some intermittent habitat for waterfowl, birds, and other species when in use.

Non-treatment wetland area (acres):	<u>Intermittent use of 200 acres</u>
Treatment wetland area (acres):	<u>N/A</u>
Riparian habitat area (acres):	<u>N/A</u>
Non-developed open space area (acres):	<u>N/A</u>
Total Project area (acres):	<u>200 acres</u>

## Community Stewardship Benefits

Describe how the project identifies opportunities to use existing publicly owned lands and easements, including, but not limited to parks, open space, community gardens, farm and agricultural preserves, school sites, and government office buildings and complexes, to capture, clean, store, and use storm water and dry weather runoff either onsite or offsite. Provide some type of quantitative measurement, which will show how the project benefits the community.

### Community Stewardship Benefits (Narrative)

<p>The Project will reduce groundwater pumping lifts and resulting energy savings. The savings will be shared with municipal and private well owners alike.</p>
---

**Multiple use/ recreation area (acres) – additionally, select the type of multiple use / recreation and associated acres by type:**

Single Sport Athletics:	<u>N/A</u>
Multiple Sport Athletics Acres:	<u>N/A</u>
Other Recreation Acres:	<u>N/A</u>
Pedestrian Trail Acres:	<u>N/A</u>
Equestrian Trail Acres:	<u>N/A</u>
Other Passive Activity:	<u>Bird watching</u>
Other Acres (describe):	<u>N/A</u>
Description:	<u>N/A</u>
<b>Total Project Area (acres):</b>	<u>200</u>

## Part 5. Project Cost Estimate

Project cost information is needed to assist in comparing benefits and cost. Additionally, knowledge of the project type and cost will assist in identifying funding sources for potential projects.

Please indicate the estimated costs of project implementation and associated funding source(s). These costs should include land purchase/easement, planning/design/engineering, construction/ implementation, environmental compliance, administration, and contingency.

<b>Approximate Total Cost:</b> (If project costs are variable, please include lower and upper range estimates.)	\$4,094,125
<b>Funding Source:</b> (If multiple sources, list each source and the percent or amount funded by each)	RRBWSD
<b>Maximum Funding Match from Implementing Agency:</b>	N/A
<b>Funding Certainty &amp; Longevity:</b>	Certain
<b>Operations &amp; Maintenance Cost:</b> (per year)	\$187,170
<b>Operations &amp; Maintenance Funding Source(s)</b> (i.e., annual budget, grant, etc. If multiple sources, list each source and the percent or amount funded by each.)	Annual Budget
<b>Operations &amp; Maintenance Funding Certainty:</b> (i.e., already included in organization's budget, contingent upon grant, etc.)	Will be included in budget.

# Kern Storm Water Resource Plan

## Project Submittal Form

This form is to be electronically filled out and e-mailed to [LMarino@ppeng.com](mailto:LMarino@ppeng.com) by June 24, 2016.

Reference: [Storm Water Resource Plan Guidelines](#), December 15, 2015  
State Water Resources Control Board

### Part 1. Lead Implementing Agency/Organizational Information

Please provide the following information regarding the project sponsor and proposed project.

**Implementing Agency / Organization / Individual:**

Rosedale-Rio Bravo Water Storage District

**Agency / Organization / Individual Address:**

849 Allen Road  
P.O. Box 20820  
Bakersfield, CA 93390

**Possible Partnering Agencies:**

None

**Name:**

Dan Bartel

**Title:**

Assistant General Manager-Engineer

**Telephone:**

661-589-6045

**Fax:**

661-589-1867

**Email:**

[dbartel@rrbwsd.com](mailto:dbartel@rrbwsd.com)

**Website:**

[www.rrbwsd.com](http://www.rrbwsd.com)

**Project Name:**

Western Rosedale In-Lieu Service Area Project

Either the latitude/longitude or a location description is required. To determine the latitude/longitude, use the closest address or intersection. If the project is linear, use the furthest upstream latitude/longitude.

**Project Latitude:**  **Project Longitude:**

<b>Location Description:</b>	Between East Side Canal and Interstate 5, south of Bowerbank, and within the District
------------------------------	---

**Project Cooperating Agency(ies)/Organization(s)/Individual(s):**

- |   |
|---|
| • |
| • |
| • |
| • |

**Project Status (e.g., new, ongoing, expansion, new phase):**

**Has the Project been submitted to IRWM Plan:**

Kern IRWMP  Poso Creek IRWMP  Not Submitted

**Does the project address any known environmental justice issues?**

Yes  No  Not Sure

**Is the project located within or adjacent to a disadvantaged community (DAC)? Refer to this [website](#).**

Within  Adjacent  No  Not Sure

**Does the project include DAC participation?**

Yes  No  Not Sure

If yes, please identify the contact person, group, or organization and describe the DAC's participation:

**What is the DAC's estimated population?**

Does the Implementing Agency own the land where the project is located? If no, describe ability to purchase land or if eminent domain is required:

Yes  No

## Part 2. Project Need

It is important to understand the need(s) or issue(s) that the proposed project will address and the benefits that it will provide. Information provided in this section defines the need(s) or issue(s) that the proposed project will address and will help to catalog existing need(s) or issue(s) in the planning area of the Kern Storm Water Resource Plan.

Please provide a 1-2 paragraph description of the need(s) or problem(s) that the proposed project will address. Discuss the benefits to water quality, water supply, flood management, environmental, and community benefits that the proposed project will bring. Discuss critical impacts or worsening conditions that will occur if the proposed project is not implemented.

### Project Need (Narrative)

The intent of the Project is to deliver surface water supplies to farmers in-lieu of pumping groundwater, allow growers to convert from existing inefficient irrigation practices to more efficient irrigation practices (such as drip irrigation). The Project is expected to absorb surface supplies up to the in-lieu system design amount of 5,630 AFY in 80 percent of the years, providing surface water for use by farmers in the Project Area in-lieu of groundwater that would otherwise be pumped, thus, conserving an average annual amount of 4,500 AF.



### Part 3. Project Description

A general description of the proposed project is needed. This section will provide information associated with the project concept and general project information. Much of the requested information may not be available for projects that are in the conceptual stages of development. An essential element of the Kern Storm Water Resource Plan consists of proposed projects. We appreciate and need your ideas.

Please provide a one or two paragraph description of the project including the general project concept, what will be constructed/implemented, how the constructed project will function, what technologies or methods will be used, as appropriate. For water quality projects, include a description of impacts to existing Total Maximum Daily Loads, NPDES permits, and/or waste discharge requirements.

#### Project Description (Narrative)

<p>The Project consists of the following:</p> <ul style="list-style-type: none"> <li>• Construction and operation of up to ten (10) miles of water conveyance pipelines, ranging in diameter from 12 inches to 40 inches; the pipelines would extend from the East Side Canal to various locations within the Project Area, which are termed North Coverage Area, Central Coverage Area, and South Coverage Area (Figure 5). The alignments and pipe diameters shown in Figure 5 may be modified during Project design.</li> <li>• Construction and operation of appurtenant facilities, such as pumps, valves, flow meters, air vents, connections to the East Side Canal (proposed turnouts), and connections to BVWSD's Supervisory Control and Data Acquisition (SCADA) system.</li> </ul>
--

**If applicable, list surface water bodies and groundwater basins associated with the proposed project:**

<ul style="list-style-type: none"> <li>• California Aqueduct</li> </ul>
<ul style="list-style-type: none"> <li>• Friant-Kern Canal</li> </ul>
<ul style="list-style-type: none"> <li>• Kern River</li> </ul>
<ul style="list-style-type: none"> <li>•</li> </ul>

**Please identify up to three available documents which contain information specific to the proposed project. Include conceptual plans, permits, drawings, and technical documents:**

<ul style="list-style-type: none"> <li>• 2016 Agricultural Water Conservation and Efficiency Grants</li> </ul>
<ul style="list-style-type: none"> <li>•</li> </ul>
<ul style="list-style-type: none"> <li>•</li> </ul>

Please identify federal, state, or local permits, which pertain to the proposed project and would need to be obtained or, if existing, would need to be amended:

• None
•
•

Please identify any existing projects or facilities, including existing water conveyance infrastructure, which would be affected, modified, or superseded as a result of implementing the proposed project:

•
•
•

Is the proposed project an element or phase of a regional or larger program?	<input checked="" type="checkbox"/> Yes <input type="checkbox"/> No
If yes, please identify the program:	Kern IRWM
Design life of the project:	<u>50</u>
Proposed Construction/Implementation Start Date:	
Proposed Construction/Implementation Completion Date:	
Ready for Construction Bid:	<input type="checkbox"/> Yes <input checked="" type="checkbox"/> No <input type="checkbox"/> N/A

Item	Status (e.g., not initiated, in process, complete)	Date (mm/dd/yyyy)
Conceptual Plans	<b>Complete</b>	
Land Acquisition/ Easements	<b>Complete</b>	
Preliminary Plans	<b>Complete</b>	
CEQA/NEPA	<b>Complete</b>	
Permits	<b>Complete</b>	
Construction Drawings	<b>In process</b>	

For projects ready for construction or implementation, including projects which do not include construction, briefly describe the project's readiness to proceed.

**Project Readiness (Narrative)**

Following the completion of design drawings and specs, the project will be ready to bid and construct.

Include any local or state board actions, code changes, or legislation needed in order to proceed with the project.

**Local or State Board Actions, Code Changes, or Legislation**

RRBWSO Board of Directors

**Please describe the dominant existing land use type for the proposed project location.**

**Agricultural**

**Please describe the dominant existing land use type for areas upstream and downstream of the proposed project location**

Upstream:	Agriculture
Downstream:	Agriculture

## Part 4. Project Benefits

Please provide a one or two paragraph description of the benefit(s) that the project will address. Benefit Categories, shown below, are referenced from the [Storm Water Resource Plan Guidelines](#), Page 31, Table 4. Each project should address at least two or more Main Benefits and as many Additional Benefits as feasible. Information you provide will be used to evaluate the project for State grant funding.

Storm Water Management Benefits		
Benefit Category	Main Benefit	Additional Benefit
<b>Water Quality</b> (while contributing to compliance with applicable permit and/or TMDL requirements)	<ul style="list-style-type: none"> <li>Increased filtration and/or treatment of run-off</li> </ul>	<ul style="list-style-type: none"> <li>Non-point source pollution control</li> <li>Reestablished natural water drainage and treatment</li> </ul>
<b>Water Supply</b> (through groundwater management and/or run-off capture and use)	<ul style="list-style-type: none"> <li><b>Water supply reliability</b></li> <li><b>Conjunctive use</b></li> </ul>	<ul style="list-style-type: none"> <li>Water conservation</li> </ul>
<b>Flood Management</b>	<ul style="list-style-type: none"> <li>Decreased flood risk by reducing run-off rate and/or volume</li> </ul>	<ul style="list-style-type: none"> <li>Reduced sanitary sewer overflows</li> </ul>
<b>Environmental and Habitat Enhancement</b>	<ul style="list-style-type: none"> <li>Environmental and habitat protection and improvement, including;                             <ul style="list-style-type: none"> <li>wetland enhancement/creation;</li> <li>riparian enhancement; and/or</li> <li>instream flow improvement</li> </ul> </li> <li>Increased urban green space</li> </ul>	<ul style="list-style-type: none"> <li>Reduced energy use, greenhouse gas emissions, or provides a carbon sink</li> <li>Reestablishment of the natural hydrograph</li> <li>Water temperature improvements</li> </ul>
<b>Community Stewardship</b>	<ul style="list-style-type: none"> <li>Employment opportunities provided</li> <li>Public Education</li> </ul>	<ul style="list-style-type: none"> <li>Community involvement</li> <li>Enhance and/or create recreational and public use areas</li> </ul>

Source: Page 31, Table 4, Storm Water Resource Plan Guidelines, State Water Resources Control Board

Please provide the following **PROJECT BENEFIT** information for all applicable components of the proposed project. Benefit categories include:

- **Water Quality**
- **Water Supply**
- **Flood Management**
- **Environmental and Habitat Enhancement**
- **Community Stewardship**

If the project benefits a disadvantaged community (DAC) describe the specific benefits to that community. Estimate the percentage of the project benefits to the DAC.

Please supply all information relevant to the proposed project. The information you provide will be used to evaluate the project for State grant funding. **Attach additional sheets if necessary.**

## Water Quality Benefits

1. Describe how the proposed project will improve source control for both pollution and dry weather runoff volume, onsite and local infiltration, and use of storm water and dry weather runoff.
2. Describe design criteria and best management practices to prevent storm water and dry weather runoff pollution and increase effective storm water and dry weather runoff management for new and upgraded infrastructure and residential, commercial, industrial, and public development
3. Describe how the proposed project complies with or is consistent with an applicable NPDES permit. The analysis should simulate the proposed watershed-based outcomes using modeling, calculations, pollutant mass balances, water volume balances, and/or other methods of analysis. Describe how the proposed project will contribute to the preservation, restoration, or enhancement of watershed processes (as described in Guidelines section VI.C.2.a)
4. Describe the water quality monitoring and data acquisition that will be implemented in conjunction with the proposed project. Describe the a) mechanisms by which data will be managed and stored; b) how data will be accessed by stakeholders and the public; c) how existing water quality and water quality monitoring will be assessed; d) frequency at which data will be updated; and e) how data gaps will be identified.

### Water Quality Benefits (Narrative)

<p>It is recognized in the IRWMP area that the majority of recharge and in-lieu recharge facilities are constructed, operated, and used by the agricultural districts and the City of Bakersfield and not by the small disadvantaged communities or the environmental water users, this project also has the potential to improve water quality as follows:</p> <ul style="list-style-type: none"> <li>• Enhancement of groundwater quality due to decreased pumping lifts and stabilization of the water table, which reduces the chances of water quality changing due to pumping from zones of less quality; and</li> <li>• Enhancements to water quality due to the importation of surface water to the District in wet years, which delivers surface water of quality suitable for the beneficial uses within the region.</li> </ul>	
Pollutant TMDL reduction (Volume per day) and (mass /unit volume) of most probable number of bacteria or indicator organisms (mpn/mL):	<u>Unknown</u>
Increase in infiltration rate above existing condition:	<u>Yes, delivers Stormwater to recharge facility</u>
Non-point source pollution control:	<u>Unknown</u>
Does project affect an Existing NPDES Permit? If applicable, describe the need for a new NPDES Permit:	<u>Unknown</u>

## Water Supply Benefits

1. Describe how the proposed project captures and reuses storm water and dry weather runoff for groundwater recharge or storage for beneficial use.
2. Please provide detailed information to quantify how the proposed project will reduce existing potable water demand.
3. Describe the water supply monitoring and data acquisition that will be implemented in conjunction with the proposed project. Describe the a) mechanisms by which data will be managed and stored; b) how data will be accessed by stakeholders and the public; c) how existing water quality and water quality monitoring will be assessed; d) frequency at which data will be updated; and e) how data gaps will be identified

### Water Supply Benefits (Narrative)

The Project is expected to absorb surface supplies up to the in-lieu system design amount of 5,630 AFY in 80 percent of the years, providing surface water for use by farmers in the Project Area in-lieu of groundwater that would otherwise be pumped, thus, conserving an average annual amount of 4,500 AF.
---

### Enhanced Water Supply or Demand Reduction Benefit Information

<b>Source of Increased Supply or Demand Reduction</b>	
<input checked="" type="checkbox"/> Groundwater	<input type="checkbox"/> Groundwater treatment
<input type="checkbox"/> Recycled water	<input checked="" type="checkbox"/> Conservation/ water use efficiency
<input type="checkbox"/> Transfer	<input type="checkbox"/> Other (describe):
<input checked="" type="checkbox"/> Increased surface water storage	<input type="checkbox"/> Ocean desalination
Type of enhanced supply or demand reduction:	Flood water will be used to recharge groundwater
Annual Yield of Supply (acre-feet):	4,500 AFY
<b>Availability by Water-Year Type (acre-feet per year)</b>	
Average Year:	<u>4,500</u>
Dry Year:	
Wet Year:	<u>5,630 AFY</u>
<b>Availability by Season (check all that apply):</b>	
<input checked="" type="checkbox"/> Summer	<input checked="" type="checkbox"/> Fall
<input checked="" type="checkbox"/> Spring	<input checked="" type="checkbox"/> Winter
<b>Does the project have the potential to reduce dependence on the Bay/Delta/Estuary?</b>	
<input checked="" type="checkbox"/> Yes	<input type="checkbox"/> No
<input type="checkbox"/> Not Sure	

## Flood Management Benefits

1. Describe how the proposed project will reestablish natural water drainage treatment and infiltration systems, or mimic natural system functions to the maximum extent feasible.
2. Describe how the proposed project will reduce flood risk by reducing runoff rate and/or volume.
3. If applicable, describe how the proposed project will reduce the risk of sanitary sewer overflows.

### Flood Management Benefits (Narrative)

The Project provides a flood management benefit inasmuch as the water stored will not contribute to increased downstream flows and flood risks from where the water is diverted.	
Description facilities protected:	N/A
Maximum volume of temporary storage of storm water runoff (acre-feet):	900; assumes 20% of avg. annual water <u>delivered as in-lieu recharge will occur during the “shoulder” months of irrigation demand, late fall or early spring, coincident with Stormwater events.</u>
Maximum increased conveyance capacity (cubic feet/second):	72
Estimated area benefiting from flood damage reduction (acres):	Unknown
Estimated level of flood protection resulting from project implementation (% annual probability of recurrence or 1-in-number of years recurrence):	Unknown
Estimated annual value of flood damage reduction provided by project (\$/year):	Unknown
Land required for project implementation (acres):	3,002

**For projects that include detention and groundwater recharge, please complete the following:**

How many acres of land drain into this detention basin? (acres):	N/A
Detention Basin area (acres):	N/A
Detention basin max. operational depth (ft.):	N/A
% of basin covered by wetlands:	N/A
Soil type:	N/A
If other than infiltration, identify method (e.g., injection) and recharge (acre-feet/year):	N/A
Estimated basin annual inflow (acre-feet/year):	N/A
Estimated basin annual outflow (acre-feet/year):	N/A



## Environmental and Habitat Enhancement Benefits

Describe how the proposed project identifies opportunities to develop, restore, or enhance habitat and open space through storm water and dry weather runoff management, including wetlands, riverside habitats, parkways, and parks. Provide some type of quantitative measurement, which will show how the project benefits the environment and enhances the natural habitat.

### Environmental and Habitat Enhancement Benefits (Narrative)

N/A.
------

Non-treatment wetland area (acres):	<a href="#">N/A.</a>
Treatment wetland area (acres):	<a href="#">N/A.</a>
Riparian habitat area (acres):	<a href="#">N/A.</a>
Non-developed open space area (acres):	<a href="#">N/A.</a>
Total Project area (acres):	<a href="#">N/A.</a>

## Community Stewardship Benefits

Describe how the project identifies opportunities to use existing publicly owned lands and easements, including, but not limited to parks, open space, community gardens, farm and agricultural preserves, school sites, and government office buildings and complexes, to capture, clean, store, and use storm water and dry weather runoff either onsite or offsite. Provide some type of quantitative measurement, which will show how the project benefits the community.

### Community Stewardship Benefits (Narrative)

[By providing in-lieu groundwater recharge](#), the Project will reduce groundwater pumping lifts and resulting energy savings. The savings will be shared with municipal and private well owners alike.

**Multiple use/ recreation area (acres) – additionally, select the type of multiple use / recreation and associated acres by type:**

Single Sport Athletics:	N/A
Multiple Sport Athletics Acres:	N/A
Other Recreation Acres:	N/A
Pedestrian Trail Acres:	N/A
Equestrian Trail Acres:	N/A
Other Passive Activity:	N/A
Other Acres (describe):	N/A
Description:	<a href="#">N/A</a>
<b>Total Project Area (acres):</b>	<a href="#">N/A</a>

## Part 5. Project Cost Estimate

Project cost information is needed to assist in comparing benefits and cost. Additionally, knowledge of the project type and cost will assist in identifying funding sources for potential projects.

Please indicate the estimated costs of project implementation and associated funding source(s). These costs should include land purchase/easement, planning/design/engineering, construction/ implementation, environmental compliance, administration, and contingency.

<b>Approximate Total Cost:</b> (If project costs are variable, please include lower and upper range estimates.)	\$4,100,000
<b>Funding Source:</b> (If multiple sources, list each source and the percent or amount funded by each)	RRBWSD
<b>Maximum Funding Match from Implementing Agency:</b>	N/A
<b>Funding Certainty &amp; Longevity:</b>	Certain
<b>Operations &amp; Maintenance Cost:</b> (per year)	\$37,000
<b>Operations &amp; Maintenance Funding Source(s)</b> (i.e., annual budget, grant, etc. If multiple sources, list each source and the percent or amount funded by each.)	Annual Budget
<b>Operations &amp; Maintenance Funding Certainty:</b> (i.e., already included in organization's budget, contingent upon grant, etc.)	Will be included in budget.

# Kern Storm Water Resource Plan

## Project Submittal Form

This form is to be electronically filled out and e-mailed to [LMarino@ppeng.com](mailto:LMarino@ppeng.com) by June 24, 2016.

Reference: [Storm Water Resource Plan Guidelines](#), December 15, 2015  
State Water Resources Control Board

### Part 1. Lead Implementing Agency/Organizational Information

Please provide the following information regarding the project sponsor and proposed project.

**Implementing Agency / Organization / Individual:**

Rosedale-Rio Bravo Water Storage District

**Agency / Organization / Individual Address:**

849 Allen Road  
P.O. Box 20820  
Bakersfield, CA 93390

**Possible Partnering Agencies:**

Buena Vista Water Storage District

**Name:**

Dan Bartel

**Title:**

Assistant General Manager-Engineer

**Telephone:**

661-589-6045

**Fax:**

661-589-1867

**Email:**

[dbartel@rrbwsd.com](mailto:dbartel@rrbwsd.com)

**Website:**

[www.rrbwsd.com](http://www.rrbwsd.com)

**Project Name:**

James Groundwater Banking and Recovery Project

Either the latitude/longitude or a location description is required. To determine the latitude/longitude, use the closest address or intersection. If the project is linear, use the furthest upstream latitude/longitude.

**Project Latitude:**  **Project Longitude:**

<b>Location Description:</b>	The Project property, known locally as McAllister Ranch, is located in the City of Bakersfield, Kern County, California within Sections 16, 21, 22, and 23, Township 30 South, Range 26 East, Mount Diablo Meridian (MDM)
------------------------------	---

**Project Cooperating Agency(ies)/Organization(s)/Individual(s):**

- |  |
|--|
| <ul style="list-style-type: none"><li>• Buena Vista Water Storage District</li></ul> |
| <ul style="list-style-type: none"><li>•</li></ul>                                    |
| <ul style="list-style-type: none"><li>•</li></ul>                                    |
| <ul style="list-style-type: none"><li>•</li></ul>                                    |

**Project Status (e.g., new, ongoing, expansion, new phase):**

**Has the Project been submitted to IRWM Plan?**

Kern IRWMP  Poso Creek IRWMP  Not Submitted

**Does the project address any known environmental justice issues?**

Yes  No  Not Sure

**Is the project located within or adjacent to a disadvantaged community (DAC)? Refer to this [website](#).**

Within  Adjacent  No  Not Sure

**Does the project include DAC participation?**

Yes  No  Not Sure

If yes, please identify the contact person, group, or organization and describe the DAC's participation:

**What is the DAC's estimated population?**

Does the Implementing Agency own the land where the project is located? If no, describe ability to purchase land or if eminent domain is required:

Yes  No

## Part 2. Project Need

It is important to understand the need(s) or issue(s) that the proposed project will address and the benefits that it will provide. Information provided in this section defines the need(s) or issue(s) that the proposed project will address and will help to catalog existing need(s) or issue(s) in the planning area of the Kern Storm Water Resource Plan.

Please provide a 1-2 paragraph description of the need(s) or problem(s) that the proposed project will address. Discuss the benefits to water quality, water supply, flood management, environmental, and community benefits that the proposed project will bring. Discuss critical impacts or worsening conditions that will occur if the proposed project is not implemented.

### Project Need (Narrative)

The Project provides a benefit to the lands, landowners, and water users within their respective boundaries by providing a reliable, affordable, and usable water supply through economic and efficient storage, distribution, and use of available water supplies, while facilitating programs that protect and benefit the groundwater basin.

The Project is intended to provide water storage and recovery capacity for RRBWSD and BVWSD for the efficient management of water supplies in their respective service areas. The Project will allow wet year water supplies to be conserved for use during dry years or when needed.

The Project's specific objectives are:

- To increase water supply reliability in the area, in a cost-effective and environmentally sound manner, by providing a means to store wet year water, that is not needed for immediate use, in the groundwater aquifer and provide a means to extract and use stored groundwater during dry years or when needed; and
- To reduce the Districts' dependence on the Sacramento-San Joaquin River Delta (also referred to herein as the Delta), from programs such as the SWP and CVP, by locally storing water in the groundwater aquifer during wet years for later extraction and use.

### Part 3. Project Description

A general description of the proposed project is needed. This section will provide information associated with the project concept and general project information. Much of the requested information may not be available for projects that are in the conceptual stages of development. An essential element of the Kern Storm Water Resource Plan consists of proposed projects. We appreciate and need your ideas.

Please provide a one or two paragraph description of the project including the general project concept, what will be constructed/implemented, how the constructed project will function, what technologies or methods will be used, as appropriate. For water quality projects, include a description of impacts to existing Total Maximum Daily Loads, NPDES permits, and/or waste discharge requirements.

#### Project Description (Narrative)

<p>The James Groundwater Storage and Recovery Project (the Project) consists of construction and operation of shallow percolation ponds totaling approximately 526 acres, levees surrounding the proposed percolation ponds, up to 10 groundwater extraction wells and well pumping plants (any combination of the operation of 2 to 6 existing wells onsite, plus construction and operation of 4 to 8 proposed new wells), water conveyance facilities, 3 pumping plants and 2 gravity turnouts, and up to 8 groundwater monitoring wells.</p> <p>The Project also includes some offsite improvements, which include two new siphon crossings along the James Canal (paralleling the existing siphon crossings at the Kern River Canal and the Burlington Northern Santa Fe (BNSF) Railroad tracks); a new gravity turnout from the Kern River to an existing basin (located between the Kern River and the Kern River Canal, near the northerly terminus of the James Canal); modifications to the existing James Canal prism (cross-section); improvements to the intake structure from the Buena Vista Canal to the Canfield Lateral; and modifications to the existing Canfield Lateral prism (cross-section).</p>
--

**If applicable, list surface water bodies and groundwater basins associated with the proposed project:**

<ul style="list-style-type: none"> <li>• California Aqueduct</li> </ul>
<ul style="list-style-type: none"> <li>• Friant-Kern Canal</li> </ul>
<ul style="list-style-type: none"> <li>• Kern River</li> </ul>
<ul style="list-style-type: none"> <li>•</li> </ul>

**Please identify up to three available documents which contain information specific to the proposed project. Include conceptual plans, permits, drawings, and technical documents:**

<ul style="list-style-type: none"> <li>• 2015 Draft Environmental Impact Report</li> </ul>
<ul style="list-style-type: none"> <li>•</li> </ul>
<ul style="list-style-type: none"> <li>•</li> </ul>

Please identify federal, state, or local permits, which pertain to the proposed project and would need to be obtained or, if existing, would need to be amended:

• RWQCB
• USACE
• California Department of Fish and Game

Please identify any existing projects or facilities, including existing water conveyance infrastructure, which would be affected, modified, or superseded as a result of implementing the proposed project:

• James Canal
• Canfield Canal
•

Is the proposed project an element or phase of a regional or larger program?:	<input checked="" type="checkbox"/> Yes <input type="checkbox"/> No
If yes, please identify the program:	Kern IRWM
Design life of the project:	<u>50 years</u>
Proposed Construction/Implementation Start Date:	
Proposed Construction/Implementation Completion Date:	
Ready for Construction Bid:	<input type="checkbox"/> Yes <input checked="" type="checkbox"/> No <input type="checkbox"/> N/A

Item	Status (e.g., not initiated, in process, complete)	Date (mm/dd/yyyy)
Conceptual Plans	Complete	
Land Acquisition/ Easements	Complete	
Preliminary Plans	In process	
CEQA/NEPA	Complete	2015
Permits	In process	
Construction Drawings	Not Initiated	

For projects ready for construction or implementation, including projects which do not include construction, briefly describe the project's readiness to proceed.



**Project Readiness (Narrative)**

Following the completion of design drawings and specs, the project will be ready to bid and construct.

Include any local or state board actions, code changes, or legislation needed in order to proceed with the project.

**Local or State Board Actions, Code Changes, or Legislation**

RRBWSD & BVWSD Board of Directors

**Please describe the dominant existing land use type for the proposed project location.**

Idle

**Please describe the dominant existing land use type for areas upstream and downstream of the proposed project location**

Upstream:	Idle
Downstream:	Idle

## Part 4. Project Benefits

Please provide a one or two paragraph description of the benefit(s) that the project will address. Benefit Categories, shown below, are referenced from the [Storm Water Resource Plan Guidelines](#), Page 31, Table 4. Each project should address at least two or more Main Benefits and as many Additional Benefits as feasible. Information you provide will be used to evaluate the project for State grant funding.

Storm Water Management Benefits		
Benefit Category	Main Benefit	Additional Benefit
<b>Water Quality</b> (while contributing to compliance with applicable permit and/or TMDL requirements)	<ul style="list-style-type: none"> <li>Increased filtration and/or treatment of run-off</li> </ul>	<ul style="list-style-type: none"> <li>Non-point source pollution control</li> <li>Reestablished natural water drainage and treatment</li> </ul>
<b>Water Supply</b> (through groundwater management and/or run-off capture and use)	<ul style="list-style-type: none"> <li><b>Water supply reliability</b></li> <li><b>Conjunctive use</b></li> </ul>	<ul style="list-style-type: none"> <li>Water conservation</li> </ul>
<b>Flood Management</b>	<ul style="list-style-type: none"> <li>Decreased flood risk by reducing run-off rate and/or volume</li> </ul>	<ul style="list-style-type: none"> <li>Reduced sanitary sewer overflows</li> </ul>
<b>Environmental and Habitat Enhancement</b>	<ul style="list-style-type: none"> <li>Environmental and habitat protection and improvement, including;                             <ul style="list-style-type: none"> <li>wetland enhancement/creation;</li> <li>riparian enhancement; and/or</li> <li>instream flow improvement</li> </ul> </li> <li>Increased urban green space</li> </ul>	<ul style="list-style-type: none"> <li>Reduced energy use, greenhouse gas emissions, or provides a carbon sink</li> <li>Reestablishment of the natural hydrograph</li> <li>Water temperature improvements</li> </ul>
<b>Community Stewardship</b>	<ul style="list-style-type: none"> <li>Employment opportunities provided</li> <li>Public Education</li> </ul>	<ul style="list-style-type: none"> <li>Community involvement</li> <li>Enhance and/or create recreational and public use areas</li> </ul>

Source: Page 31, Table 4, Storm Water Resource Plan Guidelines, State Water Resources Control Board

Please provide the following **PROJECT BENEFIT** information for all applicable components of the proposed project. Benefit categories include:

- **Water Quality**
- **Water Supply**
- **Flood Management**
- **Environmental and Habitat Enhancement**
- **Community Stewardship**

If the project benefits a disadvantaged community (DAC) describe the specific benefits to that community. Estimate the percentage of the project benefits to the DAC.

Please supply all information relevant to the proposed project. The information you provide will be used to evaluate the project for State grant funding. **Attach additional sheets if necessary.**

## Water Quality Benefits

1. Describe how the proposed project will improve source control for both pollution and dry weather runoff volume, onsite and local infiltration, and use of storm water and dry weather runoff.
2. Describe design criteria and best management practices to prevent storm water and dry weather runoff pollution and increase effective storm water and dry weather runoff management for new and upgraded infrastructure and residential, commercial, industrial, and public development
3. Describe how the proposed project complies with or is consistent with an applicable NPDES permit. The analysis should simulate the proposed watershed-based outcomes using modeling, calculations, pollutant mass balances, water volume balances, and/or other methods of analysis. Describe how the proposed project will contribute to the preservation, restoration, or enhancement of watershed processes (as described in Guidelines section VI.C.2.a)
4. Describe the water quality monitoring and data acquisition that will be implemented in conjunction with the proposed project. Describe the a) mechanisms by which data will be managed and stored; b) how data will be accessed by stakeholders and the public; c) how existing water quality and water quality monitoring will be assessed; d) frequency at which data will be updated; and e) how data gaps will be identified.

### Water Quality Benefits (Narrative)

<p>Water quality benefits would not apply as a primary benefit for this project. However, recharge basins within the District allow for direct recharge of surface water originating from the SWP, the CVP, Kern River usually suitable for irrigation. The sources vary in quality, but are all typically suitable for irrigation and do not degrade the groundwater basin from its designated use. This project also has the potential to improve water quality as follows:</p> <ul style="list-style-type: none"> <li>• Enhancement of groundwater quality due to decreased pumping lifts and stabilization of the water table, which reduces the chances of water quality changing due to pumping from zones of less quality; and</li> <li>• Enhancements to water quality due to the importation of surface water to the District in wet years, which delivers surface water of quality suitable for the beneficial uses within the region.</li> </ul> <p>Additionally, the District, Project, and City of Bakersfield are within the Kern Fan. The water quality benefits produced by the Project are shared with the City and other nearby municipal entities.</p>	
Pollutant TMDL reduction (Volume per day) and (mass /unit volume) of most probable number of bacteria or indicator organisms (mpn/mL):	<u>Unknown</u>
Increase in infiltration rate above existing condition:	<u>Yes, delivers Stormwater to recharge facility</u>
Non-point source pollution control:	<u>Unknown</u>
Does project affect an Existing NPDES Permit? If applicable, describe the need for a new NPDES Permit:	<u>Unknown</u>

## Water Supply Benefits

1. Describe how the proposed project captures and reuses storm water and dry weather runoff for groundwater recharge or storage for beneficial use.
2. Please provide detailed information to quantify how the proposed project will reduce existing potable water demand.
3. Describe the water supply monitoring and data acquisition that will be implemented in conjunction with the proposed project. Describe the a) mechanisms by which data will be managed and stored; b) how data will be accessed by stakeholders and the public; c) how existing water quality and water quality monitoring will be assessed; d) frequency at which data will be updated; and e) how data gaps will be identified

### Water Supply Benefits (Narrative)

<p>The Project is expected to absorb surface supplies up to approximately 57,600 AFY.</p> <p>Additionally, the project would:</p> <ul style="list-style-type: none"> <li>• Improve the regional reliability of water supply.</li> <li>• Increase operational flexibility.</li> <li>• Increase direct spreading and basin absorptive capability.</li> <li>• Increase local unconfined groundwater quality.</li> <li>• Make use of available groundwater storage.</li> <li>• Contribute to the groundwater basin for use during periods of peak demand</li> </ul>
---

### Enhanced Water Supply or Demand Reduction Benefit Information

<b>Source of Increased Supply or Demand Reduction</b>	
<input checked="" type="checkbox"/> Groundwater	<input type="checkbox"/> Groundwater treatment
<input type="checkbox"/> Recycled water	<input checked="" type="checkbox"/> Conservation/ water use efficiency
<input type="checkbox"/> Transfer	<input type="checkbox"/> Other (describe):
<input checked="" type="checkbox"/> Increased surface water storage	<input type="checkbox"/> Ocean desalination
Type of enhanced supply or demand reduction:	Flood water will be used to recharge groundwater
Annual Yield of Supply (acre-feet):	11,520
<b>Availability by Water-Year Type (acre-feet per year)</b>	
Average Year:	11,520 AF ; [11,520 AFY = 57,600 AF * ( 2 wet years / 10 years )]
Dry Year:	
Wet Year:	57,600 AF
<b>Availability by Season (check all that apply):</b>	
<input checked="" type="checkbox"/> Summer	<input checked="" type="checkbox"/> Fall
<input checked="" type="checkbox"/> Spring	<input checked="" type="checkbox"/> Winter
<b>Does the project have the potential to reduce dependence on the Bay/Delta/Estuary?</b>	
<input checked="" type="checkbox"/> Yes	<input type="checkbox"/> No
<input type="checkbox"/> Not Sure	

## Flood Management Benefits

1. Describe how the proposed project will reestablish natural water drainage treatment and infiltration systems, or mimic natural system functions to the maximum extent feasible.
2. Describe how the proposed project will reduce flood risk by reducing runoff rate and/or volume.
3. If applicable, describe how the proposed project will reduce the risk of sanitary sewer overflows.

### Flood Management Benefits (Narrative)

<p>The Project provides a flood management benefit inasmuch as the water delivered to the direct recharge facility during times of Stormwater management will be diverted and not contribute to increased downstream flows and flood risks.</p>	
Description facilities protected:	Regional water management facilities
Maximum volume of temporary storage of storm water runoff (acre-feet):	57,600
Maximum increased conveyance capacity (cubic feet/second):	258; based on preliminary evaluation
Estimated area benefiting from flood damage reduction (acres):	Unknown
Estimated level of flood protection resulting from project implementation (% annual probability of recurrence or 1-in-number of years recurrence):	Unknown
Estimated annual value of flood damage reduction provided by project (\$/year):	Unknown
Land required for project implementation (acres):	658

**For projects that include detention and groundwater recharge, please complete the following:**

How many acres of land drain into this detention basin? (acres):	N/A
Detention Basin area (acres):	526
Detention basin max. operational depth (ft.):	1 to 4
% of basin covered by wetlands:	Unknown
Soil type:	Loam
If other than infiltration, identify method (e.g., injection) and recharge (acre-feet/year):	
Estimated basin annual inflow (acre-feet/year):	11,520
Estimated basin annual outflow (acre-feet/year):	0

## Environmental and Habitat Enhancement Benefits

Describe how the proposed project identifies opportunities to develop, restore, or enhance habitat and open space through storm water and dry weather runoff management, including wetlands, riverside habitats, parkways, and parks. Provide some type of quantitative measurement, which will show how the project benefits the environment and enhances the natural habitat.

### Environmental and Habitat Enhancement Benefits (Narrative)

The Project will provide waterfowl with a place to rest and nest, intermittently, when they have water in the ponds and are being utilized for recharge purposes.

Non-treatment wetland area (acres):	<u>526, intermittent use when filled with water for recharge</u>
Treatment wetland area (acres):	<u>N/A</u>
Riparian habitat area (acres):	<u>N/A</u>
Non-developed open space area (acres):	<u>N/A</u>
Total Project area (acres):	<u>658</u>

## Community Stewardship Benefits

Describe how the project identifies opportunities to use existing publicly owned lands and easements, including, but not limited to parks, open space, community gardens, farm and agricultural preserves, school sites, and government office buildings and complexes, to capture, clean, store, and use storm water and dry weather runoff either onsite or offsite. Provide some type of quantitative measurement, which will show how the project benefits the community.

### Community Stewardship Benefits (Narrative)

<p>Once constructed the facility provides a habitat for various birds and waterfowl that also provides an opportunity for the public to view the birds. The Project will reduce groundwater pumping lifts and resulting energy savings. The savings will be shared with municipal and private well owners alike.</p>
--

**Multiple use/ recreation area (acres) – additionally, select the type of multiple use / recreation and associated acres by type:**

Single Sport Athletics:	<u>N/A</u>
Multiple Sport Athletics Acres:	<u>N/A</u>
Other Recreation Acres:	<u>N/A</u>
Pedestrian Trail Acres:	<u>N/A</u>
Equestrian Trail Acres:	<u>N/A</u>
Other Passive Activity:	<u>Bird viewing</u>
Other Acres (describe):	<u>N/A</u>
Description:	<u>N/A</u>
<b>Total Project Area (acres):</b>	<u>526</u>



## Part 5. Project Cost Estimate

Project cost information is needed to assist in comparing benefits and cost. Additionally, knowledge of the project type and cost will assist in identifying funding sources for potential projects.

Please indicate the estimated costs of project implementation and associated funding source(s). These costs should include land purchase/easement, planning/design/engineering, construction/ implementation, environmental compliance, administration, and contingency.

<b>Approximate Total Cost:</b> (If project costs are variable, please include lower and upper range estimates.)	Approximately \$60,000,000 is a preliminary estimate.
<b>Funding Source:</b> (If multiple sources, list each source and the percent or amount funded by each)	RRBWSD and BVWSD
<b>Maximum Funding Match from Implementing Agency:</b>	N/A
<b>Funding Certainty &amp; Longevity:</b>	Certain
<b>Operations &amp; Maintenance Cost:</b> (per year)	\$100,000
<b>Operations &amp; Maintenance Funding Source(s)</b> (i.e., annual budget, grant, etc. If multiple sources, list each source and the percent or amount funded by each.)	Annual Budget
<b>Operations &amp; Maintenance Funding Certainty:</b> (i.e., already included in organization's budget, contingent upon grant, etc.)	Will be included in budget.

# Kern Storm Water Resource Plan

## Project Submittal Form

This form is to be electronically filled out and e-mailed to [LMarino@ppeng.com](mailto:LMarino@ppeng.com) by June 24, 2016.

Reference: [Storm Water Resource Plan Guidelines](#), December 15, 2015  
State Water Resources Control Board

### Part 1. Lead Implementing Agency/Organizational Information

Please provide the following information regarding the project sponsor and proposed project.

**Implementing Agency / Organization / Individual:**

Shafter-Wasco Irrigation District

**Agency / Organization / Individual Address:**

16294 Central Valley Hwy, Wasco, CA 93280

**Possible Partnering Agencies:**

Buena Vista Water Storage District

**Name:**

Dana Munn

**Title:**

General Manager

**Telephone:**

(661) 758-5153

**Fax:**

**Email:**

dmunn@SWID.org

**Website:**

www.SWID.org

**Project Name:**

Shafter-Wasco Irrigation District Recharge Project

Either the latitude/longitude or a location description is required. To determine the latitude/longitude, use the closest address or intersection. If the project is linear, use the furthest upstream latitude/longitude.

**Project Latitude:**  **Project Longitude:**

<b>Location Description:</b>	The Project will consist of up to seven 20-acres storm water recharge basins which total approximately 140 acres on property to be selected within a 4,000-acre survey area located within the Shafter-Wasco Irrigation District, Kern County, CA. The SWID Recharge Project is located within the Shafter-Wasco Irrigation District Boundaries, to the northeast of Shafter, CA, and on the west bank of the Calloway Canal at the corner of Beech and Fresno Avenues.
------------------------------	---

**Project Cooperating Agency(ies)/Organization(s)/Individual(s):**

- |   |
|---|
| • |
| • |
| • |
| • |

**Project Status (e.g., new, ongoing, expansion, new phase):**

**Has the Project been submitted to IRWM Plan?**

Kern IRWMP  Poso Creek IRWMP  Not Submitted

**Does the project address any known environmental justice issues?**

Yes  No  Not Sure

**Is the project located within or adjacent to a disadvantaged community (DAC)? Refer to this [website](#).**

Within  Adjacent  No  Not Sure

**Does the project include DAC participation?**

Yes  No  Not Sure

If yes, please identify the contact person, group, or organization and describe the DAC's participation:

What is the DAC's estimated population?

Does the Implementing Agency own the land where the project is located? If no, describe ability to purchase land or if eminent domain is required:

Yes  No

## Part 2. Project Need

It is important to understand the need(s) or issue(s) that the proposed project will address and the benefits that it will provide. Information provided in this section defines the need(s) or issue(s) that the proposed project will address and will help to catalog existing need(s) or issue(s) in the planning area of the Kern Storm Water Resource Plan.

Please provide a 1-2 paragraph description of the need(s) or problem(s) that the proposed project will address. Discuss the benefits to water quality, water supply, flood management, environmental, and community benefits that the proposed project will bring. Discuss critical impacts or worsening conditions that will occur if the proposed project is not implemented.

### Project Need (Narrative)

The infrequent, less reliable, and inadequacy of surface water supplies delivered into Kern County have increased the importance of utilizing supplies as they become available. The Project addresses this by capturing surplus storm waters and allowing for their delivery to spreading ponds. By using the water to recharge the aquifer underlying the District, the Project helps to offset demand on surface supplies in dry years, increasing local supply reliability.

Additionally, implementation of the Project will help achieve sustainable groundwater levels by reducing annual demand, increasing storm water capture, and avoid the adverse environmental and economic burden associated with groundwater declines, including increased energy consumption, increased emission of greenhouse gases and the eventual fallowing or conversion of agricultural lands to non-agricultural uses.

### Part 3. Project Description

A general description of the proposed project is needed. This section will provide information associated with the project concept and general project information. Much of the requested information may not be available for projects that are in the conceptual stages of development. An essential element of the Kern Storm Water Resource Plan consists of proposed projects. We appreciate and need your ideas.

Please provide a one or two paragraph description of the project including the general project concept, what will be constructed/implemented, how the constructed project will function, what technologies or methods will be used, as appropriate. For water quality projects, include a description of impacts to existing Total Maximum Daily Loads, NPDES permits, and/or waste discharge requirements.

#### Project Description (Narrative)

The Project consists of constructing up to (7) 20-acre ponds, totaling approximately 140 acres, within the District to capture storm water for the purpose of groundwater recharge. Construction of the ponds will require temporary staging and storage areas for materials and equipment that will be located onsite for each basin. The Project would also require the construction of the following conveyance facilities:

- Project turnout to conveyance channel. This structure would consist of a turnout and pipeline. The size of the pipeline will depend on the total pond area served by the turnout as surface water will be conveyed from the Calloway Canal to the Project’s distribution canal.
- Distribution Canal Check Structures within the Recharge Ponds. These structures would consist of a concrete weir with board guides constructed downstream of the recharge basin turnout and would serve the purpose of maintaining the desired upstream water surface to allow flow into each recharge basin. There may be one check structure for multiple ponds, depending on slope and if the canal is located central to the pond layout. Several check structures will be installed to serve the 20 ponds; the exact number is to be determined in the design following selection of a site. The design may include a canal with appropriate flow capacity to serve the ponds. Canals would be earthen and trapezoidal in shape, cut about two feet below grade with an embankment about two feet above grade.
- Basin turnouts. These structures would vary in size from 18 inches to 24 inches and would lead from the distribution canal into each recharge basin. There would be at most one inlet for each basin. Typical existing design allow four basins to be served by one check structure.

**If applicable, list surface water bodies and groundwater basins associated with the proposed project:**

<ul style="list-style-type: none"> <li>• The District overlies the Kern Subbasin</li> </ul>
<ul style="list-style-type: none"> <li>•</li> </ul>
<ul style="list-style-type: none"> <li>•</li> </ul>
<ul style="list-style-type: none"> <li>•</li> </ul>

**Please identify up to three available documents which contain information specific to the proposed project. Include conceptual plans, permits, drawings, and technical documents:**

<ul style="list-style-type: none"> <li>• SWID Recharge Project, Final IS &amp; Mitigated ND, February 2015</li> </ul>
<ul style="list-style-type: none"> <li>•</li> </ul>
<ul style="list-style-type: none"> <li>•</li> </ul>

Please identify federal, state, or local permits, which pertain to the proposed project and would need to be obtained or, if existing, would need to be amended:

•
•
•

Please identify any existing projects or facilities, including existing water conveyance infrastructure, which would be affected, modified, or superseded as a result of implementing the proposed project:

• Calloway Canal, for conveyance
•
•

Is the proposed project an element or phase of a regional or larger program?	<input checked="" type="checkbox"/> Yes <input type="checkbox"/> No
If yes, please identify the program:	<u>Poso Creek IRWMP</u>
Design life of the project:	<u>50 years</u>
Proposed Construction/Implementation Start Date:	<u>Yet Unkown</u>
Proposed Construction/Implementation Completion Date:	<u>Yet Unkown</u>
Ready for Construction Bid:	<input type="checkbox"/> Yes <input checked="" type="checkbox"/> No <input type="checkbox"/> N/A

Item	Status (e.g., not initiated, in process, complete)	Date (mm/dd/yyyy)
Conceptual Plans	<b>Complete</b>	6/1/2016
Land Acquisition/ Easements	<b>Not initiated</b>	
Preliminary Plans	<b>In Process</b>	
CEQA/NEPA	<b>Complete</b>	2/2015
Permits	<b>In Process</b>	
Construction Drawings	<b>Not initiated</b>	

For projects ready for construction or implementation, including projects which do not include construction, briefly describe the project's readiness to proceed.

**Project Readiness (Narrative)**

SWID prepared a Final Initial Study & Mitigated Negative Declaration for the Project in February of 2015. This report considered all effects that the project might have on the environment as well as identify the best locations for the recharge ponds within District boundaries. Once a site is selected, the design and construction of the 140 acre recharge site can progress very rapidly since the District Engineer/Manager has extensive experience constructing spreading basins in the District. The Project is not very complicated as it involves converting existing irrigated land into spreading ponds by reshaping and install simple water diversion structures. For the SWID Recharge Project each construction phase is expected to have the following stages and general durations: 1) one month for site preparation including clearing, grubbing, and grading; 2) three months for installation of turnouts, water control structures, pipelines, and canals; 3) one month for system interconnection and clean up.

Include any local or state board actions, code changes, or legislation needed in order to proceed with the project.

**Local or State Board Actions, Code Changes, or Legislation**

No State Board actions or legislation would be required. As with all projects within the District, all appropriate approvals from the SWID Board of Directors will be obtained.

**Please describe the dominant existing land use type for the proposed project location.**

Agricultural – Crop.

**Please describe the dominant existing land use type for areas upstream and downstream of the proposed project location**

Upstream:	Agricultural – Crop
Downstream:	Agricultural - Crop

## Part 4. Project Benefits

Please provide a one or two paragraph description of the benefit(s) that the project will address. Benefit Categories, shown below, are referenced from the [Storm Water Resource Plan Guidelines](#), Page 31, Table 4. Each project should address at least two or more Main Benefits and as many Additional Benefits as feasible. Information you provide will be used to evaluate the project for State grant funding.

Storm Water Management Benefits		
Benefit Category	Main Benefit	Additional Benefit
<b>Water Quality</b> (while contributing to compliance with applicable permit and/or TMDL requirements)	<ul style="list-style-type: none"> <li>Increased filtration and/or treatment of run-off</li> </ul>	<ul style="list-style-type: none"> <li>Non-point source pollution control</li> <li>Reestablished natural water drainage and treatment</li> </ul>
<b>Water Supply</b> (through groundwater management and/or run-off capture and use)	<ul style="list-style-type: none"> <li>Water supply reliability</li> <li>Conjunctive use</li> </ul>	<ul style="list-style-type: none"> <li>Water conservation</li> </ul>
<b>Flood Management</b>	<ul style="list-style-type: none"> <li>Decreased flood risk by reducing run-off rate and/or volume</li> </ul>	<ul style="list-style-type: none"> <li>Reduced sanitary sewer overflows</li> </ul>
<b>Environmental and Habitat Enhancement</b>	<ul style="list-style-type: none"> <li>Environmental and habitat protection and improvement, including;                             <ul style="list-style-type: none"> <li>wetland enhancement/creation;</li> <li>riparian enhancement; and/or</li> <li>instream flow improvement</li> </ul> </li> <li>Increased urban green space</li> </ul>	<ul style="list-style-type: none"> <li>Reduced energy use, greenhouse gas emissions, or provides a carbon sink</li> <li>Reestablishment of the natural hydrograph</li> <li>Water temperature improvements</li> </ul>
<b>Community Stewardship</b>	<ul style="list-style-type: none"> <li>Employment opportunities provided</li> <li>Public Education</li> </ul>	<ul style="list-style-type: none"> <li>Community involvement</li> <li>Enhance and/or create recreational and public use areas</li> </ul>

Source: Page 31, Table 4, Storm Water Resource Plan Guidelines, State Water Resources Control Board

Please provide the following **PROJECT BENEFIT** information for all applicable components of the proposed project. Benefit categories include:

- **Water Quality**
- **Water Supply**
- **Flood Management**
- **Environmental and Habitat Enhancement**
- **Community Stewardship**

If the project benefits a disadvantaged community (DAC) describe the specific benefits to that community. Estimate the percentage of the project benefits to the DAC.

Please supply all information relevant to the proposed project. The information you provide will be used to evaluate the project for State grant funding. **Attach additional sheets if necessary.**



## Water Quality Benefits

1. Describe how the proposed project will improve source control for both pollution and dry weather runoff volume, onsite and local infiltration, and use of storm water and dry weather runoff.
2. Describe design criteria and best management practices to prevent storm water and dry weather runoff pollution and increase effective storm water and dry weather runoff management for new and upgraded infrastructure and residential, commercial, industrial, and public development
3. Describe how the proposed project complies with or is consistent with an applicable NPDES permit. The analysis should simulate the proposed watershed-based outcomes using modeling, calculations, pollutant mass balances, water volume balances, and/or other methods of analysis. Describe how the proposed project will contribute to the preservation, restoration, or enhancement of watershed processes (as described in Guidelines section VI.C.2.a)
4. Describe the water quality monitoring and data acquisition that will be implemented in conjunction with the proposed project. Describe the a) mechanisms by which data will be managed and stored; b) how data will be accessed by stakeholders and the public; c) how existing water quality and water quality monitoring will be assessed; d) frequency at which data will be updated; and e) how data gaps will be identified.

### Water Quality Benefits (Narrative)

<p>The Project protects water quality in that storm water captured by the Project originates from uplands that form the watersheds of the lakes and reservoirs that will release water recharged by the Project. These source waters are largely unimpaired, with unsubstantial water quality issues. While flood releases conveyed overland and through unlined canals and river channels may mobilize substantial sediment loads, because the path of the storm water will not cross major urban or agricultural areas, with the exception of sediment, loadings of constituents other than sediment are expected to be low and will remain stable over time.</p>	
Pollutant TMDL reduction (Volume per day) and (mass /unit volume) of most probable number of bacteria or indicator organisms (mpn/mL):	<u>Unknown</u>
Increase in infiltration rate above existing condition:	<u>140 acres will be converted to recharge ponds</u>
Non-point source pollution control:	<u>Unknown</u>
Does project affect an Existing NPDES Permit? If applicable, describe the need for a new NPDES Permit:	<u>No</u>

## Water Supply Benefits

1. Describe how the proposed project captures and reuses storm water and dry weather runoff for groundwater recharge or storage for beneficial use.
2. Please provide detailed information to quantify how the proposed project will reduce existing potable water demand.
3. Describe the water supply monitoring and data acquisition that will be implemented in conjunction with the proposed project. Describe the a) mechanisms by which data will be managed and stored; b) how data will be accessed by stakeholders and the public; c) how existing water quality and water quality monitoring will be assessed; d) frequency at which data will be updated; and e) how data gaps will be identified

### Water Supply Benefits (Narrative)

Improved overall water supply, water supply reliability, energy savings and reduced greenhouse gas emissions will result from the long-term increase in groundwater elevations in the Project area due to recharge of storm water. Therefore, although the Project will be operated as a groundwater storage facility with groundwater elevations increasing during periods when water is recharged and declining when groundwater is extracted for beneficial uses, the Project will be operated so as to maintain average groundwater elevations that are higher than they would be absent the Project. Supporting local groundwater levels will aid in regional compliance with the Sustainable Groundwater Management Act and will enable groundwater pumpers (both Project proponents and local domestic, agricultural and municipal users) to reduce pumping costs and lessen the need to deepen wells. The 140 acre recharge ponds are anticipated to absorb 0.5 acre-feet per day, or 70 AF per Day for up to 6 months, 4 out of 10 years. The equates to an average annual amount of 5,040 AF =  $[70 \text{ AF} * 30 \text{ days} * 6 \text{ months} * 4] / 10$ . In addition, converting the land from irrigation to recharge ponds removes 490 AFY of demand =  $140 \text{ A} * 3.5 \text{ AFY/A demand}$ .

### Enhanced Water Supply or Demand Reduction Benefit Information

<b>Source of Increased Supply or Demand Reduction</b>	
<input checked="" type="checkbox"/> Groundwater	<input type="checkbox"/> Groundwater treatment
<input type="checkbox"/> Recycled water	<input checked="" type="checkbox"/> Conservation/ water use efficiency
<input type="checkbox"/> Transfer	<input type="checkbox"/> Other (describe):
<input checked="" type="checkbox"/> Increased surface water storage	<input type="checkbox"/> Ocean desalination
Type of enhanced supply or demand reduction:	Flood Water
Annual Yield of Supply (acre-feet):	Approximately 5,530 AF = 5,040 AF + 490 AF
<b>Availability by Water-Year Type (acre-feet per year)</b>	
Average Year:	<u>5,040 AF</u>
Dry Year:	<u>490 AF</u>
Wet Year:	<u>13,090 AF = 12,600 AF + 490 AF; 12,600 AF = [70 AF * 30 days * 6 months]</u>
<b>Availability by Season (check all that apply):</b>	
<input type="checkbox"/> Summer	<input checked="" type="checkbox"/> Fall
<input type="checkbox"/> Spring	<input checked="" type="checkbox"/> Winter

**Does the project have the potential to reduce dependence on the Sacramento San Joaquin Bay-Delta?**

Yes

No

Not Sure

**Flood Management Benefits**

1. Describe how the proposed project will reestablish natural water drainage treatment and infiltration systems, or mimic natural system functions to the maximum extent feasible.
2. Describe how the proposed project will reduce flood risk by reducing runoff rate and/or volume.
3. If applicable, describe how the proposed project will reduce the risk of sanitary sewer overflows.

**Flood Management Benefits (Narrative)**

The Project helps water infrastructure systems adapt to flood flows by alleviating pressure on an aging system. Existing research on climate change suggests that one of the primary outcomes will be a shift in snowfall to rainfall and an increase in peak storm flows. Providing an outlet for storm water flows that channels these flows to groundwater recharge facilities improves the functionality of existing infrastructure by diverting storm water flows from overtaxed conveyance channels during large storm events, and enhancing water supply reliability during dry years.

Description facilities protected:	
Maximum volume of temporary storage of storm water runoff (acre-feet):	70 AFD; 2,100 AF per Month
Maximum increased conveyance capacity (cubic feet/second):	Yet Unknown
Estimated area benefiting from flood damage reduction (acres):	Yet Unknown
Estimated level of flood protection resulting from project implementation (% annual probability of recurrence or 1-in-number of years recurrence):	Yet Unknown
Estimated annual value of flood damage reduction provided by project (\$/year):	Yet Unknown
Land required for project implementation (acres):	140

**For projects that include detention and groundwater recharge, please complete the following:**

How many acres of land drain into this detention basin? (acres):	Yet Unknown
Detention Basin area (acres):	140
Detention basin max. operational depth (ft.):	1-4 feet
% of basin covered by wetlands:	Intermittent use during wet periods
Soil type:	Yet Unknown
If other than infiltration, identify method (e.g., injection) and	Yet Unknown

recharge (acre-feet/year):	
Estimated basin annual inflow (acre-feet/year):	5,040 AFY average
Estimated basin annual outflow (acre-feet/year):	0

## Environmental and Habitat Enhancement Benefits

Describe how the proposed project identifies opportunities to develop, restore, or enhance habitat and open space through storm water and dry weather runoff management, including wetlands, riverside habitats, parkways, and parks. Provide some type of quantitative measurement, which will show how the project benefits the environment and enhances the natural habitat.

### Environmental and Habitat Enhancement Benefits (Narrative)

<p>During periods when storm water is available for recharge, the spreading ponds will act as intermittent wetlands that will benefit wildlife including migratory birds.</p>
---

Non-treatment wetland area (acres):	<u>140 intermittent</u>
Treatment wetland area (acres):	<u>Yet Unknown</u>
Riparian habitat area (acres):	<u>Yet Unknown</u>
Non-developed open space area (acres):	<u>140</u>
Total Project area (acres):	<u>140</u>

## Community Stewardship Benefits

Describe how the project identifies opportunities to use existing publicly owned lands and easements, including, but not limited to parks, open space, community gardens, farm and agricultural preserves, school sites, and government office buildings and complexes, to capture, clean, store, and use storm water and dry weather runoff either onsite or offsite. Provide some type of quantitative measurement, which will show how the project benefits the community.

### Community Stewardship Benefits (Narrative)

As noted in the water supply benefit section, recharging the groundwater aquifer provides a benefit to the local community by helping to increase the groundwater table elevation and lower the required pumping lift near the project. Therefore, all wells providing water for public or private use receive a benefit. The quantitative benefit of the project will be determined as design details are finalized. The construction of the recharge site provides some temporary employment.

**Multiple use/ recreation area (acres) – additionally, select the type of multiple use / recreation and associated acres by type:**

Single Sport Athletics:	<u>N/A</u>
Multiple Sport Athletics Acres:	<u>N/A</u>
Other Recreation Acres:	<u>N/A</u>
Pedestrian Trail Acres:	<u>N/A</u>
Equestrian Trail Acres:	<u>N/A</u>
Other Passive Activity:	<u>Bird Viewing</u>
Other Acres (describe):	<u>N/A</u>
Description:	<u>Reduced pump lift for all pumps in the vicinity of the Project.</u>
<b>Total Project Area (acres):</b>	<u>140</u>

## Part 5. Project Cost Estimate

Project cost information is needed to assist in comparing benefits and cost. Additionally, knowledge of the project type and cost will assist in identifying funding sources for potential projects.

Please indicate the estimated costs of project implementation and associated funding source(s). These costs should include land purchase/easement, planning/design/engineering, construction/ implementation, environmental compliance, administration, and contingency.

<b>Approximate Total Cost:</b> (If project costs are variable, please include lower and upper range estimates.)	\$5,021,550
<b>Funding Source:</b> (If multiple sources, list each source and the percent or amount funded by each)	Local funding will match State grant and possible Federal grant funds.
<b>Maximum Funding Match from Implementing Agency:</b>	\$2,521,550 is estimated if this State funding is successful
<b>Funding Certainty &amp; Longevity:</b>	
<b>Operations &amp; Maintenance Cost:</b> (per year)	\$25,000 annually
<b>Operations &amp; Maintenance Funding Source(s)</b> (i.e., annual budget, grant, etc. If multiple sources, list each source and the percent or amount funded by each.)	District annual revenues
<b>Operations &amp; Maintenance Funding Certainty:</b> (i.e., already included in organization's budget, contingent upon grant, etc.)	It will be included in District's annual budget

# Appendix C: Project Scoring Forms



Project Name / Sponsor: 101_Schuster Spreading Grounds / Semitropic	Storm Water Management Benefits	
	Main Benefit (4-5 pts ea)	Additional Benefit (1-3 pts ea)
<b>MAIN AND ADDITIONAL BENEFITS CATEGORIES</b>		
<b>WATER QUALITY - while contributing to compliance with applicable permit and/or TMDL requirements</b>		
* Increased filtration and/or treatment of runoff		
** Nonpoint source pollution control		1
** Reestablishment of natural water drainage and treatment		
<b>WATER SUPPLY - through groundwater management and/or runoff capture and use</b>		
* Water supply reliability		
** Water conservation		
* Conjunctive use	5	
** Water conservation		
<b>FLOOD MANAGEMENT</b>		
* Decreased flood risk by reducing runoff rate and/or volume	5	
** Reduced sanitary sewer overflows		
<b>ENVIRONMENTAL</b>		
* Environmental and habitat protection and improvement, including: (a) wetland enhancement/creation; (b) riparian enhancement; (c) instream flow improvement	4	
** Reduced energy use, greenhouse gas emissions, or provides carbon sink		
** Reestablishment of the natural hydrograph		
* Increased urban green space		
** Water temperature improvements		
<b>COMMUNITY</b>		
* Employment opportunities provided		
** Community involvement		1
* Public education		
** Enhance and/or create recreational and public use areas		
<b>TOTAL MAIN BENEFITS (8 pts minimum)</b>	<b>14</b>	
<b>TOTAL ADDITIONAL BENEFITS</b>		<b>2</b>
<b>TOTAL MAIN + ADDITIONAL BENEFITS</b>		<b>16</b>

- 0 = criteria does not apply
- 1 = Criteria may apply/need more information
- 2 = Additional Benefit Criteria partially applies
- 3 = Additional Benefit Criteria fully applies
- 4 = Main Benefit Criteria partially applies
- 5 = Main Benefit Criteria fully applies

PROJECT READINESS CHECKLIST	YES	NO
Is the Project ready to implement (Yes=1), (No=0)?		0
Is the Project cost well defined (1) or just an estimate (0)?		0
Is the land currently owned by a public agency (1) or does it need to be acquired (0)?	1	
Is the environmental permitting process complete (1) or not yet started (0)?		0
Does the agency have the funds available for the 50% local funding match (Yes=1), (No=0)?		0
<b>PROJECT READINESS SCORE</b>		<b>1</b>

Project Name / Sponsor: 102_Pond-Poso Spreading Grounds, Phase 2 / Semitropic	Storm Water Management Benefits	
	Main Benefit (4-5 pts ea)	Additional Benefit (1-3 pts ea)
<b>MAIN AND ADDITIONAL BENEFITS CATEGORIES</b>		
<b>WATER QUALITY - while contributing to compliance with applicable permit and/or TMDL requirements</b>		
* Increased filtration and/or treatment of runoff		
** Nonpoint source pollution control		1
** Reestablishment of natural water drainage and treatment		
<b>WATER SUPPLY - through groundwater management and/or runoff capture and use</b>		
* Water supply reliability	5	
** Water conservation		
* Conjunctive use		
** Water conservation		
<b>FLOOD MANAGEMENT</b>		
* Decreased flood risk by reducing runoff rate and/or volume	5	
** Reduced sanitary sewer overflows		
<b>ENVIRONMENTAL</b>		
* Environmental and habitat protection and improvement, including: (a) wetland enhancement/creation; (b) riparian enhancement; (c) instream flow improvement	4	
** Reduced energy use, greenhouse gas emissions, or provides carbon sink		
** Reestablishment of the natural hydrograph		
* Increased urban green space		
** Water temperature improvements		
<b>COMMUNITY</b>		
* Employment opportunities provided		
** Community involvement		
* Public education		
** Enhance and/or create recreational and public use areas		
<b>TOTAL MAIN BENEFITS (8 pts minimum)</b>	<b>14</b>	
<b>TOTAL ADDITIONAL BENEFITS</b>		<b>1</b>
<b>TOTAL MAIN + ADDITIONAL BENEFITS</b>		<b>15</b>

- 0 = criteria does not apply
- 1 = Criteria may apply/need more information
- 2 = Additional Benefit Criteria partially applies
- 3 = Additional Benefit Criteria fully applies
- 4 = Main Benefit Criteria partially applies
- 5 = Main Benefit Criteria fully applies

PROJECT READINESS CHECKLIST	YES	NO
Is the Project ready to implement (Yes=1), (No=0)?	0.5	
Is the Project cost well defined (1) or just an estimate (0)?		0
Is the land currently owned by a public agency (1) or does it need to be acquired (0)?	1	
Is the environmental permitting process complete (1) or not yet started (0)?	0.5	
Does the agency have the funds available for the 50% local funding match (Yes=1), (No=0)?		0
<b>PROJECT READINESS SCORE</b>		<b>2</b>

Project Name / Sponsor: 103_Stored Water Recovery Unit, Element of the Semitropic Groundwater Bank / Semitropic	Storm Water Management Benefits	
	Main Benefit (4-5 pts ea)	Additional Benefit (1-3 pts ea)
<b>MAIN AND ADDITIONAL BENEFITS CATEGORIES</b>		
<b>WATER QUALITY - while contributing to compliance with applicable permit and/or TMDL requirements</b>		
* Increased filtration and/or treatment of runoff		
** Nonpoint source pollution control		1
** Reestablishment of natural water drainage and treatment		
<b>WATER SUPPLY - through groundwater management and/or runoff capture and use</b>		
* Water supply reliability	5	
** Water conservation		
* Conjunctive use		
** Water conservation		
<b>FLOOD MANAGEMENT</b>		
* Decreased flood risk by reducing runoff rate and/or volume	5	
** Reduced sanitary sewer overflows		
<b>ENVIRONMENTAL</b>		
* Environmental and habitat protection and improvement, including: (a) wetland	4	
** Reduced energy use, greenhouse gas emissions, or provides carbon sink		
** Reestablishment of the natural hydrograph		
* Increased urban green space		
** Water temperature improvements		
<b>COMMUNITY</b>		
* Employment opportunities provided		
** Community involvement		
* Public education		
** Enhance and/or create recreational and public use areas		2
<b>TOTAL MAIN BENEFITS (8 pts minimum)</b>	<b>14</b>	
<b>TOTAL ADDITIONAL BENEFITS</b>		<b>3</b>
<b>TOTAL MAIN + ADDITIONAL BENEFITS</b>		<b>17</b>

- 0 = criteria does not apply
- 1 = Criteria may apply/need more information
- 2 = Additional Benefit Criteria partially applies
- 3 = Additional Benefit Criteria fully applies
- 4 = Main Benefit Criteria partially applies
- 5 = Main Benefit Criteria fully applies

PROJECT READINESS CHECKLIST	YES	NO
Is the Project ready to implement (Yes=1), (No=0)?	0.5	0
Is the Project cost well defined (1) or just an estimate (0)?		0
Is the land currently owned by a public agency (1) or does it need to be acquired (0)?	0.5	0
Is the environmental permitting process complete (1) or not yet started (0)?	1	0
Does the agency have the funds available for the 50% local funding match (Yes=1), (No=0)?		0
<b>PROJECT READINESS SCORE</b>		<b>2</b>

Project Name / Sponsor: 104_Entrance Ponds to the Pond Poso Spreading Grounds / Semitropic	Storm Water Management Benefits	
	Main Benefit (4-5 pts ea)	Additional Benefit (1-3 pts ea)
<b>MAIN AND ADDITIONAL BENEFITS CATEGOTRIES</b>		
<b>WATER QUALITY - while contributing to compliance with applicable permit and/or TMDL requirements</b>		
* Increased filtration and/or treatment of runoff		
** Nonpoint source pollution control		1
** Reestablishment of natural water drainage and treatment		
<b>WATER SUPPLY - through groundwater management and/or runoff capture and use</b>		
* Water supply reliability	5	
** Water conservation		
* Conjunctive use		
** Water conservation		
<b>FLOOD MANAGEMENT</b>		
* Decreased flood risk by reducing runoff rate and/or volume	5	
** Reduced sanitary sewer overflows		
<b>ENVIRONMENTAL</b>		
* Environmental and habitat protection and improvement, including: (a) wetland enhancement/creation; (b) riparian enhancement; (c) instream flow improvement	5	
** Reduced energy use, greenhouse gas emmisions, or provides carbon sink		
** Reestablishment of the natural hydrograph		
* Increased urban green space		
** Water temperature improvements		
<b>COMMUNITY</b>		
* Employment opportunities provided		
** Community involvement		
* Public education		
** Enhance and/or create recreational and public use areas		2
<b>TOTAL MAIN BENEFITS (8 pts minimum)</b>	<b>15</b>	
<b>TOTAL ADDITIONAL BENEFITS</b>		<b>3</b>
<b>TOTAL MAIN + ADDITIONAL BENEFITS</b>		<b>18</b>

- 0 = criteria does not apply
- 1 = Criteria may apply/need more information
- 2 = Additional Benefit Criteria partially applies
- 3 = Additional Benefit Criteria fully applies
- 4 = Main Benefit Criteria partially applies
- 5 = Main Benefit Criteria fully applies

PROJECT READINESS CHECKLIST	YES	NO
Is the Project ready to implement (Yes=1), (No=0)?	0.5	
Is the Project cost well defined (1) or just an estimate (0)?		0
Is the land currently owned by a public agency (1) or does it need to be acquired (0)?	1	
Is the environmental permitting process complete (1) or not yet started (0)?	0.5	
Does the agency have the funds available for the 50% local funding match (Yes=1), (No=0)?		0
<b>PROJECT READINESS SCORE</b>		<b>2</b>

Project Name / Sponsor: 105_Caliente Creek Habitat Restoration and Groundwater Recharge Projects—Design and Construction/Kern County	Storm Water Management Benefits	
	Main Benefit (4-5 pts ea)	Additional Benefit (1-3 pts ea)
<b>MAIN AND ADDITIONAL BENEFITS CATEGORIES</b>		
<b>WATER QUALITY - while contributing to compliance with applicable permit and/or TMDL requirements</b>		
* Increased filtration and/or treatment of runoff		
** Nonpoint source pollution control		1
** Reestablishment of natural water drainage and treatment		1
<b>WATER SUPPLY - through groundwater management and/or runoff capture and use</b>		
* Water supply reliability		
** Water conservation		
* Conjunctive use		
** Water conservation		1
<b>FLOOD MANAGEMENT</b>		
* Decreased flood risk by reducing runoff rate and/or volume	4	
** Reduced sanitary sewer overflows		
<b>ENVIRONMENTAL</b>		
* Environmental and habitat protection and improvement, including: (a) wetland enhancement/creation; (b) riparian enhancement; (c) instream flow improvement	5	
** Reduced energy use, greenhouse gas emissions, or provides carbon sink		
** Reestablishment of the natural hydrograph		
* Increased urban green space		
** Water temperature improvements		
<b>COMMUNITY</b>		
* Employment opportunities provided		
** Community involvement		1
* Public education		
** Enhance and/or create recreational and public use areas		
<b>TOTAL MAIN BENEFITS (8 pts minimum)</b>	<b>9</b>	
<b>TOTAL ADDITIONAL BENEFITS</b>		<b>4</b>
<b>TOTAL MAIN + ADDITIONAL BENEFITS</b>		<b>13</b>

- 0 = criteria does not apply
- 1 = Criteria may apply/need more information
- 2 = Additional Benefit Criteria partially applies
- 3 = Additional Benefit Criteria fully applies
- 4 = Main Benefit Criteria partially applies
- 5 = Main Benefit Criteria fully applies

PROJECT READINESS CHECKLIST	YES	NO
Is the Project ready to implement (Yes=1), (No=0)?	0.5	
Is the Project cost well defined (1) or just an estimate (0)?		0
Is the land currently owned by a public agency (1) or does it need to be acquired (0)?		0
Is the environmental permitting process complete (1) or not yet started (0)?		0
Does the agency have the funds available for the 50% local funding match (Yes=1), (No=0)?		0
<b>PROJECT READINESS SCORE</b>		<b>0.5</b>

Project Name / Sponsor: <b>106_Cuddy Creek Restoration Project / Kern County</b>	Storm Water Management Benefits	
	Main Benefit (4-5 pts ea)	Additional Benefit (1-3 pts ea)
<b>MAIN AND ADDITIONAL BENEFITS CATEGOTRIES</b>		
<b>WATER QUALITY - while contributing to compliance with applicable permit and/or TMDL requirements</b>		
* Increased filtration and/or treatment of runoff		
** Nonpoint source pollution control		1
** Reestablishment of natural water drainage and treatment		
<b>WATER SUPPLY - through groundwater management and/or runoff capture and use</b>		
* Water supply reliability	4	
** Water conservation		
* Conjunctive use		
** Water conservation		
<b>FLOOD MANAGEMENT</b>		
* Decreased flood risk by reducing runoff rate and/or volume		
** Reduced sanitary sewer overflows		
<b>ENVIRONMENTAL</b>		
* Environmental and habitat protection and improvement, including: (a) wetland enhancement/creation; (b) riparian enhancement; (c) instream flow improvement	4	
** Reduced energy use, greenhouse gas emmisions, or provides carbon sink		
** Reestablishment of the natural hydrograph		
* Increased urban green space		
** Water temperature improvements		
<b>COMMUNITY</b>		
* Employment opportunities provided		
** Community involvement		1
* Public education		
** Enhance and/or create recreational and public use areas		1
<b>TOTAL MAIN BENEFITS (8 pts minimum)</b>	<b>8</b>	
<b>TOTAL ADDITIONAL BENEFITS</b>		<b>3</b>
<b>TOTAL MAIN + ADDITIONAL BENEFITS</b>		<b>11</b>

- 0 = criteria does not apply
- 1 = Criteria may apply/need more information
- 2 = Additional Benefit Criteria partially applies
- 3 = Additional Benefit Criteria fully applies
- 4 = Main Benefit Criteria partially applies
- 5 = Main Benefit Criteria fully applies

PROJECT READINESS CHECKLIST	YES	NO
Is the Project ready to implement (Yes=1), (No=0)?	0.5	
Is the Project cost well defined (1) or just an estimate (0)?		0
Is the land currently owned by a public agency (1) or does it need to be acquired (0)?		0
Is the environmental permitting process complete (1) or not yet started (0)?	1	
Does the agency have the funds available for the 50% local funding match (Yes=1), (No=0)?		0
<b>PROJECT READINESS SCORE</b>		<b>1.5</b>

Project Name / Sponsor: 107_Sandy Creek Bank and Erosion Protection Project / Kern County	Storm Water Management Benefits	
	Main Benefit (4-5 pts ea)	Additional Benefit (1-3 pts ea)
<b>MAIN AND ADDITIONAL BENEFITS CATEGOTRIES</b>		
<b>WATER QUALITY - while contributing to compliance with applicable permit and/or TMDL requirements</b>		
* Increased filtration and/or treatment of runoff	4	
** Nonpoint source pollution control		
** Reestablishment of natural water drainage and treatment		
<b>WATER SUPPLY - through groundwater management and/or runoff capture and use</b>		
* Water supply reliability		
** Water conservation		2
* Conjunctive use		
** Water conservation		
<b>FLOOD MANAGEMENT</b>		
* Decreased flood risk by reducing runoff rate and/or volume	5	
** Reduced sanitary sewer overflows		
<b>ENVIRONMENTAL</b>		
* Environmental and habitat protection and improvement, including: (a) wetland enhancement/creation; (b) riparian enhancement; (c) instream flow improvement		
** Reduced energy use, greenhouse gas emmisions, or provides carbon sink		
** Reestablishment of the natural hydrograph		
* Increased urban green space		
** Water temperature improvements		
<b>COMMUNITY</b>		
* Employment opportunities provided		
** Community involvement		1
* Public education		
** Enhance and/or create recreational and public use areas		
<b>TOTAL MAIN BENEFITS (8 pts minimum)</b>	<b>9</b>	
<b>TOTAL ADDITIONAL BENEFITS</b>		<b>3</b>
<b>TOTAL MAIN + ADDITIONAL BENEFITS</b>		<b>12</b>

- 0 = criteria does not apply
- 1 = Criteria may apply/need more information
- 2 = Additional Benefit Criteria partially applies
- 3 = Additional Benefit Criteria fully applies
- 4 = Main Benefit Criteria partially applies
- 5 = Main Benefit Criteria fully applies

PROJECT READINESS CHECKLIST	YES	NO
Is the Project ready to implement (Yes=1), (No=0)?		0
Is the Project cost well defined (1) or just an estimate (0)?		0
Is the land currently owned by a public agency (1) or does it need to be acquired (0)?		0
Is the environmental permitting process complete (1) or not yet started (0)?		0
Does the agency have the funds available for the 50% local funding match (Yes=1), (No=0)?		0
<b>PROJECT READINESS SCORE</b>		<b>0</b>

Project Name/Sponsor: 108_The Palms Storm Water Recharge and Recovery Project/Buena Vista WSD	Storm Water Management Benefits	
MAIN AND ADDITIONAL BENEFITS CATEGORIES	Main Benefit (4-5 pts ea)	Additional Benefit (1-3 pts ea)
<b>WATER QUALITY - while contributing to compliance with applicable permit and/or TMDL requirements</b>		
* Increased filtration and/or treatment of runoff	4	
** Nonpoint source pollution control		
** Reestablishment of natural water drainage and treatment		
<b>WATER SUPPLY - through groundwater management and/or runoff capture and use</b>		
* Water supply reliability	5	
** Water conservation		
* Conjunctive use		
** Water conservation		
<b>FLOOD MANAGEMENT</b>		
* Decreased flood risk by reducing runoff rate and/or volume	5	
** Reduced sanitary sewer overflows		
<b>ENVIRONMENTAL</b>		
* Environmental and habitat protection and improvement, including: (a) wetland enhancement/creation; (b) riparian enhancement; (c) instream flow improvement		
** Reduced energy use, greenhouse gas emissions, or provides carbon sink		2
** Reestablishment of the natural hydrograph		2
* Increased urban green space		
** Water temperature improvements		
<b>COMMUNITY</b>		
* Employment opportunities provided		
** Community involvement		
* Public education		
** Enhance and/or create recreational and public use areas		
<b>TOTAL MAIN BENEFITS (8 pts minimum)</b>	<b>14</b>	
<b>TOTAL ADDITIONAL BENEFITS</b>		<b>4</b>
<b>TOTAL MAIN + ADDITIONAL BENEFITS</b>		<b>18</b>

- 0 = criteria does not apply
- 1 = Criteria may apply/need more information
- 2 = Additional Benefit Criteria partially applies
- 3 = Additional Benefit Criteria fully applies
- 4 = Main Benefit Criteria partially applies
- 5 = Main Benefit Criteria fully applies

PROJECT READINESS CHECKLIST	YES	NO
Is the Project ready to implement (Yes=1), (No=0)?	0.5	0
Is the Project cost well defined (1) or just an estimate (0)?		0
Is the land currently owned by a public agency (1) or does it need to be acquired (0)?	1	
Is the environmental permitting process complete (1) or not yet started (0)?	0.5	
Does the agency have the funds available for the 50% local funding match (Yes=1), (No=0)?	1	
<b>PROJECT READINESS SCORE</b>		<b>3</b>



Project Name / Sponsor: 109_Stockdale East Groundwater Recharge Project / Rosedale Rio Bravo WSD	Storm Water Management Benefits		
	MAIN AND ADDITIONAL BENEFITS CATEGORIES	Main Benefit (4-5 pts ea)	Additional Benefit (1-3 pts ea)
<b>WATER QUALITY - while contributing to compliance with applicable permit and/or TMDL requirements</b>			
* Increased filtration and/or treatment of runoff	4		
** Nonpoint source pollution control		1	
** Reestablishment of natural water drainage and treatment			
<b>WATER SUPPLY - through groundwater management and/or runoff capture and use</b>			
* Water supply reliability	5		
** Water conservation			
* Conjunctive use			
** Water conservation			
<b>FLOOD MANAGEMENT</b>			
* Decreased flood risk by reducing runoff rate and/or volume	5		
** Reduced sanitary sewer overflows			
<b>ENVIRONMENTAL</b>			
* Environmental and habitat protection and improvement, including: (a) wetland enhancement/creation; (b) riparian enhancement; (c) instream flow improvement	5		
** Reduced energy use, greenhouse gas emissions, or provides carbon sink		1	
** Reestablishment of the natural hydrograph			
* Increased urban green space			
** Water temperature improvements			
<b>COMMUNITY</b>			
* Employment opportunities provided			
** Community involvement			
* Public education			
** Enhance and/or create recreational and public use areas			
<b>TOTAL MAIN BENEFITS (8 pts minimum)</b>	<b>19</b>		
<b>TOTAL ADDITIONAL BENEFITS</b>		<b>2</b>	
<b>TOTAL MAIN + ADDITIONAL BENEFITS</b>		<b>21</b>	

- 0 = criteria does not apply
- 1 = Criteria may apply/need more information
- 2 = Additional Benefit Criteria partially applies
- 3 = Additional Benefit Criteria fully applies
- 4 = Main Benefit Criteria partially applies
- 5 = Main Benefit Criteria fully applies

PROJECT READINESS CHECKLIST	YES	NO
Is the Project ready to implement (Yes=1), (No=0)?	0.5	
Is the Project cost well defined (1) or just an estimate (0)?		0
Is the land currently owned by a public agency (1) or does it need to be acquired (0)?	1	0
Is the environmental permitting process complete (1) or not yet started (0)?	0.5	0
Does the agency have the funds available for the 50% local funding match (Yes=1), (No=0)?		0
<b>PROJECT READINESS SCORE</b>		<b>2</b>

Project Name/Sponsor: 110_Western Rosedale In-Lieu Service Area Project / Rosedale-Rio Bravo WSD	Storm Water Management Benefits	
MAIN AND ADDITIONAL BENEFITS CATEGORIES	Main Benefit (4-5 pts ea)	Additional Benefit (1-3 pts ea)
<b>WATER QUALITY - while contributing to compliance with applicable permit and/or TMDL requirements</b>		
* Increased filtration and/or treatment of runoff	4	
** Nonpoint source pollution control		1
** Reestablishment of natural water drainage and treatment		
<b>WATER SUPPLY - through groundwater management and/or runoff capture and use</b>		
* Water supply reliability		
** Water conservation		
* Conjunctive use	5	
** Water conservation		
<b>FLOOD MANAGEMENT</b>		
* Decreased flood risk by reducing runoff rate and/or volume	5	
** Reduced sanitary sewer overflows		
<b>ENVIRONMENTAL</b>		
* Environmental and habitat protection and improvement, including: (a) wetland enhancement/creation; (b) riparian enhancement; (c) instream flow improvement		
** Reduced energy use, greenhouse gas emissions, or provides carbon sink		1
** Reestablishment of the natural hydrograph		
* Increased urban green space		
** Water temperature improvements		
<b>COMMUNITY</b>		
* Employment opportunities provided		
** Community involvement		
* Public education		
** Enhance and/or create recreational and public use areas		
<b>TOTAL MAIN BENEFITS (8 pts minimum)</b>	<b>14</b>	
<b>TOTAL ADDITIONAL BENEFITS</b>		<b>2</b>
<b>TOTAL MAIN + ADDITIONAL BENEFITS</b>		<b>16</b>

- 0 = criteria does not apply
- 1 = Criteria may apply/need more information
- 2 = Additional Benefit Criteria partially applies
- 3 = Additional Benefit Criteria fully applies
- 4 = Main Benefit Criteria partially applies
- 5 = Main Benefit Criteria fully applies

PROJECT READINESS CHECKLIST	YES	NO
Is the Project ready to implement (Yes=1), (No=0)?	0.5	0
Is the Project cost well defined (1) or just an estimate (0)?		0
Is the land currently owned by a public agency (1) or does it need to be acquired (0)?	1	
Is the environmental permitting process complete (1) or not yet started (0)?	1	
Does the agency have the funds available for the 50% local funding match (Yes=1), (No=0)?		0
<b>PROJECT READINESS SCORE</b>		<b>2.5</b>

Project Name/Sponsor: 111_James Groundwater Storage & Recovery Project/Rosedale-Rio Bravo WSD	Storm Water Management Benefits	
MAIN AND ADDITIONAL BENEFITS CATEGORIES	Main Benefit (4-5 pts ea)	Additional Benefit (1-3 pts ea)
<b>WATER QUALITY - while contributing to compliance with applicable permit and/or TMDL requirements</b>		
* Increased filtration and/or treatment of runoff		
** Nonpoint source pollution control		
** Reestablishment of natural water drainage and treatment		
<b>WATER SUPPLY - through groundwater management and/or runoff capture and use</b>		
* Water supply reliability	5	
** Water conservation		
* Conjunctive use		
** Water conservation		
<b>FLOOD MANAGEMENT</b>		
* Decreased flood risk by reducing runoff rate and/or volume	5	
** Reduced sanitary sewer overflows		
<b>ENVIRONMENTAL</b>		
* Environmental and habitat protection and improvement, including: (a) wetland enhancement/creation; (b) riparian enhancement; (c) instream flow improvement	5	
** Reduced energy use, greenhouse gas emissions, or provides carbon sink		
** Reestablishment of the natural hydrograph		
* Increased urban green space		
** Water temperature improvements		
<b>COMMUNITY</b>		
* Employment opportunities provided		
** Community involvement		
* Public education		
** Enhance and/or create recreational and public use areas		2
<b>TOTAL MAIN BENEFITS (8 pts minimum)</b>	<b>15</b>	
<b>TOTAL ADDITIONAL BENEFITS</b>		<b>2</b>
<b>TOTAL MAIN + ADDITIONAL BENEFITS</b>		<b>17</b>

- 0 = criteria does not apply
- 1 = Criteria may apply/need more information
- 2 = Additional Benefit Criteria partially applies
- 3 = Additional Benefit Criteria fully applies
- 4 = Main Benefit Criteria partially applies
- 5 = Main Benefit Criteria fully applies

PROJECT READINESS CHECKLIST	YES	NO
Is the Project ready to implement (Yes=1), (No=0)?	0.5	0
Is the Project cost well defined (1) or just an estimate (0)?		0
Is the land currently owned by a public agency (1) or does it need to be acquired (0)?	1	
Is the environmental permitting process complete (1) or not yet started (0)?	1	0
Does the agency have the funds available for the 50% local funding match (Yes=1), (No=0)?		0
<b>PROJECT READINESS SCORE</b>		<b>2.5</b>

Project Name/Sponsor: <b>112_Shafter-Wasco Irrigation District Recharge Project/Shafter-Wasco ID</b>	Storm Water Management Benefits	
	Main Benefit (4-5 pts ea)	Additional Benefit (1-3 pts ea)
<b>MAIN AND ADDITIONAL BENEFITS CATEGOTRIES</b>		
<b>WATER QUALITY - while contributing to compliance with applicable permit and/or TMDL requirements</b>		
* Increased filtration and/or treatment of runoff		
** Nonpoint source pollution control		1
** Reestablishment of natural water drainage and treatment		
<b>WATER SUPPLY - through groundwater management and/or runoff capture and use</b>		
* Water supply reliability		
** Water conservation		
* Conjunctive use	5	
** Water conservation		
<b>FLOOD MANAGEMENT</b>		
* Decreased flood risk by reducing runoff rate and/or volume	5	
** Reduced sanitary sewer overflows		
<b>ENVIRONMENTAL</b>		
* Environmental and habitat protection and improvement, including: (a) wetland enhancement/creation; (b) riparian enhancement; (c) instream flow improvement	5	
** Reduced energy use, greenhouse gas emmissions, or provides carbon sink		
** Reestablishment of the natural hydrograph		
* Increased urban green space		
** Water temperature improvements		
<b>COMMUNITY</b>		
* Employment opportunities provided		
** Community involvement		1
* Public education		
** Enhance and/or create recreational and public use areas		
<b>TOTAL MAIN BENEFITS (8 pts minimum)</b>	<b>15</b>	
<b>TOTAL ADDITIONAL BENEFITS</b>		<b>2</b>
<b>TOTAL MAIN + ADDITIONAL BENEFITS</b>		<b>17</b>

- 0 = criteria does not apply
- 1 = Criteria may apply/need more information
- 2 = Additional Benefit Criteria partially applies
- 3 = Additional Benefit Criteria fully applies
- 4 = Main Benefit Criteria partially applies
- 5 = Main Benefit Criteria fully applies

PROJECT READINESS CHECKLIST	YES	NO
Is the Project ready to implement (Yes=1), (No=0)?	0.5	
Is the Project cost well defined (1) or just an estimate (0)?		0
Is the land currently owned by a public agency (1) or does it need to be acquired (0)?		0
Is the environmental permitting process complete (1) or not yet started (0)?	1	
Does the agency have the funds available for the 50% local funding match (Yes=1), (No=0)?	1	0
<b>PROJECT READINESS SCORE</b>		<b>2.5</b>

# Appendix D: Recharge to Groundwater

Groundwater Quality Assessment Report,  
Kern River Watershed Coalition Authority

**Kern River Watershed Coalition Authority**

# **Groundwater Quality Assessment Report**

Kern County, California  
February 2015

Prepared for:

**Kern River Watershed Coalition Authority**  
Kern County, California

Prepared by:

**Provost & Pritchard Consulting Group**  
Bakersfield, California

**Land IQ**

Sacramento, California

**Todd Groundwater**

Alameda, California



## 8 Recharge to Groundwater

Groundwater recharge is the sum of the hydrogeologic processes through which water percolates from the ground surface into a groundwater aquifer. These processes require two basic components in order for groundwater recharge to occur, available water and permeable materials at the ground surface. Recharge cannot occur in a location without both of these components. The capacity for recharge is also largely a function of these two components; groundwater recharge is highest in areas with very permeable material and abundant surface water.

Source water quality is another recharge consideration. In general, highly effective recharge areas are a net benefit to water quality because they tend to dilute the concentrations of groundwater constituents. However, areas with poor quality surface water and high permeability could negatively impact groundwater quality.

### 8.1 Sources of Recharge

Groundwater recharge in the KRWCA area comes from a variety of sources, and each source has different water quality. It is likely that these recharge sources, including natural and managed recharge, generally have lower concentrations of nitrate and salinity than the receiving groundwater aquifer, while other sources (like some agricultural return flows and wastewater discharges) may have higher concentrations of nitrates and salinity. The main sources of recharge and their expected effect on the groundwater quality are discussed below.

#### 8.1.1 Natural Recharge

For purposes of this report, natural recharge is percolation from rainfall on areas with native vegetation. Percolation from rainfall in cropped and urban areas is discussed in other categories below. In addition to precipitation and evapotranspiration (ET), natural recharge is also a function of how much water is stored in near-surface soils temporarily and later returned to the atmosphere via transpiration or through bare soil evaporation.

#### 8.1.2 Agricultural Return Flow

Agricultural return flow is the water that runs off crop land and/or percolates past the root zone when more irrigation water is applied than the crop needs, or that the root zone can absorb or hold. Agricultural return flow results from applied irrigation water and precipitation in excess of the soil root zone water holding capacity and ET requirements of the crop. Return flows consist of the excess water that either percolates directly beneath the field or runs off and percolates in nearby areas. When percolated water passes through the vadose zone and reaches the water table, it is considered groundwater. Because some groundwater can be “perched” on shallow clay layers, and variations in aquifer stratigraphy can confine and/or change flow directions, it is important to consider the particular groundwater zone that return flows encounter. The hydrogeology of the study area is discussed in **Section 5**. The water requirements of individual crops and the associated irrigation methods and efficiencies, result in a range of potential recharge rates from agricultural return flows.



### 8.1.3 Municipal Return Flow

Municipal return flow results from precipitation and water applied to the ground surface in municipal settings that exceeds evaporation, consumptive use, and root zone water holding capacity. It may also result from percolation from stormwater detention basins or water that flows through pavements. Demands are typically associated with urban and suburban irrigation or recreational uses. The major municipal purveyors in the KRWCA area include the City of Bakersfield, Cal Water, and other smaller purveyors, including but not limited to, the City of Shafter, City of Wasco, City of Delano, City of McFarland, Vaughn Water Company, Greenfield County Water District, West Kern Water District, Buttonwillow County Water District, Oildale Mutual Water Company, North of the River Municipal Water District, Stockdale Mutual Water Company, East Niles Community Services District, City of Arvin, and Lamont Community Services District.

### 8.1.4 Wastewater

Treated wastewater from wastewater treatment plants (**WWTPs**) within the KRWCA area is generally used for irrigation. When irrigation demands are low in the winter, effluent may be discharged to onsite ponds for storage, and/or evaporation and percolation, depending on permit conditions. These WWTPs are regulated by Central Valley Regional Water Quality Control Board (**CVRWQCB**) individual waste discharge requirements (**WDRs**) to control potential impacts to groundwater. Several WWTPs serve the metro Bakersfield area. Some of the WWTPs within the KRWCA area include the City of Bakersfield WWTP No. 2, City of Bakersfield WWTP No. 3, North of the River Sanitary District No. 1 WWTP, Kern Sanitation Authority WWTP, Lamont PUD, and the Shafter-Minter Field WWTP. Other cities and communities in KRWCA also have WWTPs with WDRs.

Some developed lands in the KRWCA utilize septic tanks with leach lines (septic systems). Recharge occurs from the septic systems.

Wastewater from food processors, confined animal operations, and other industries is also often used for irrigation, and contributes to recharge. In some cases, food processing wastewater flows to wastewater treatment plants. The CVRWQCB regulates wastewater discharges from these industries to control groundwater quality impacts.

### 8.1.5 Managed Recharge and Canal Seepage

Managed recharge and banking is performed in the area by multiple water agencies through various mechanisms, including canal seepage as water is conveyed, recharge ponds, and seepage from reservoirs. In-lieu recharge activities by displacing groundwater use with surface water is not evaluated in this section. For the purposes of this evaluation, no distinction is made between managed recharge conducted by water agencies and others to increase groundwater in storage for general resources improvement in the study area, and more formal banking projects where water is recharged for storage on behalf of an outside party for later recovery and use outside of the project area. Managed recharge associated with both of these practices is often accomplished in recharge or percolation ponds. As many of the canals and the Kern River used to transport water in the area are unlined, seepage from these canals is also used as a component of managed recharge. Seepage from lined canals, smaller water conveyance facilities (ditches and pipelines) also occurs and contributes to recharge. Local streams are also sometimes used for recharge. The water used in managed recharge comes either from





the Kern River, local streams, or from imported surface water conveyed through the State Water Project and Central Valley Project. These water supplies are generally of high quality, and managed recharge is considered to have an overall positive benefit to groundwater quality in the KRWCA area.

## 8.2 Significant Recharge Areas and Rates

### 8.2.1 Natural Recharge

Natural recharge is a function of precipitation, ET, and soil moisture holding capacity, as noted above. Precipitation and ET records for the primary KRWCA area are available from the California Irrigation Management Information System (**CIMIS**) Station. Average annual precipitation from the Shafter Station (No. 5) is 6.3 inches, which is relatively low compared to an annual potential evapotranspiration (**ET**) of 57 inches. As a consequence, deep percolation of precipitation past the root zone occurs infrequently or not at all. A daily soil moisture balance was completed for the Kern Fan (Todd, 2012) using the Thornthwaite and Mather method (1955 and 1957). This soil moisture balance showed that precipitation is generally consumed by evapotranspiration within a few days of a rainfall event, and there is no excess available water for recharge to groundwater.

In the secondary area where precipitation volumes are higher and evapotranspiration is generally lower, natural recharge is likely the primary source of recharge to groundwater. However, precipitation and runoff varies greatly, estimates of ET from vegetation are more difficult (due to the wide variety of vegetation and little research to support estimates), and there is little unconsolidated material in this area, as indicated in **Section 5**. The variations in precipitation and runoff, difficulty of estimating ET, limited extent of unconsolidated material, and predominance of fractured bedrock groundwater makes estimation of natural recharge in these areas infeasible.

### 8.2.2 Agricultural Return Flow

Return flows vary geographically with changes in crop type, soil type, and irrigation practices. A partial evaluation of these components for major crops was completed for the KRWCA primary area by New Fields Agricultural and Environmental Resources (Kimmelshue and Tillman 2013). These estimates considered all of the factors related to applied water for the major crops; including irrigation efficiencies in varying soil types, and the water required for cultural practices such as leaching of accumulated salts from the soil. Applied water estimates were prepared by Kimmelshue and Tillman (2013) for select crops by soil region and crop and irrigation system type. These estimates indicated a range of applied water rates from 2.7 acre-feet per year per acre (**AFY/ac**) for grapes in the foothills and 5.1 AFY/ac for alfalfa in the Kern Fan area. Kimmelshue and Tillman (2013) found that irrigation efficiency ranges from 75 to 95 percent over the KRWCA primary area, and that rates are generally higher in the foothills and southern Kern Fan. Return flow rates vary from 0.16 AFY/ac for grapes in the foothills to 1.23 AFY/ac for corn and wheat in the Kern Fan area.

The Kern County Water Agency (**KCWA**) estimates total agricultural return flow in Water Supply Reports as part of the hydrologic accounting of the Kern County Subbasin (KCWA 2002 through 2011). These estimates indicate that total agricultural return flows to the Kern County Subbasin range between 378,000 acre-feet per year (**AFY**) to 753,000 AFY.



### 8.2.3 Municipal Return Flow

Municipal return flows, landscape irrigation runoff, deep percolation, stormwater runoff and recharge occur mainly in urban areas and are limited in volume. Based on estimates in the Bakersfield area, 50 to 70 percent of municipal supply is used outdoors in some capacity. In addition storm water runoff from precipitation flows into unlined sumps that allow water to percolate to the groundwater. A reasonable assumption is that 12 percent of the outdoor use recharges the aquifer as return flow. In Bakersfield (the city and Cal Water systems combined), the estimated return flow over the period from 2006 through 2010 was 9,100 AFY over a combined service area of 65,587 acres, or 0.14 AFY/ac. While detailed data was not available from other water systems, the remaining communities in the KRWCA area are expected to have a similar rate of return flow.

### 8.2.4 Wastewater

Available information regarding the volumes discharged to WWTP disposal ponds is limited. However, the City of Bakersfield indicates that WWTP No. 3 and North of the River Service District WWTP No. 1 discharge 3,000 AFY to 7,200 AFY per plant into effluent ponds. Additional wastewater is used as an irrigation water source in other parts of the County. Treated wastewater is regulated by the CVRWQCB under specific wastewater discharge permits. Recharge from septic systems is significant in KRWCA, but is not measured or estimated.

Recharge from wastewater generated by food processing, confined animal facilities, and other industries may also result in high volumes of water for disposal. Because a high percentage of that wastewater is used for irrigation of crops, it is important not to double-count it in water balances.

### 8.2.5 Managed Recharge and Seepage

The rate of recharge for managed recharge projects and the recharge associated with seepage vary annually depending on hydrology. In normal and wet years, recharge and banking occur in large amounts, and more water is transported and recharged through canal, river, and stream flow. In dry years, banking generally does not occur, and recharge in canals, river, and streams are limited as well due to reduced duration and amounts of flows being conveyed. Because of the variability of rate and location, managed recharge and seepage is examined in detail in [Section 8.3](#).

## 8.3 Groundwater Recharge Projects

There are a number of groundwater recharge projects in the KRWCA area. They range from agencies with one or two ponds used to recharge surplus water to large operations that bank and recover water on behalf of outside parties. The recharge facilities associated with these projects are shown on [Figure 8-1](#). Agencies and major projects actively recharging groundwater within the KRWCA primary and secondary areas include:

- Arvin-Edison Water Storage District;
- Buena Vista Water District;
- The City of Bakersfield;
- Kern County Water Agency – Pioneer, Berrenda Mesa, and Kern River Banking;



- Kern Delta Water District;
- Kern Water Bank Authority;
- North Kern Water Storage District;
- Rosedale Rio Bravo Water Storage District;
- Semitropic Water Storage District;
- West Kern Water District;
- Golden Hills Community Services District; and,
- Tehachapi Cummings County Water District.

Estimates of recharged water by agency and major project in the primary Central Valley portion of KRWCA for the period of 2006 through 2010 are shown in **Table 8-1**. These are the most recent available managed recharge data. The largest recharge project is the Kern Water Bank (**KWB**), which recharged an average of 66,618 AFY during this time period. Even this large project has a large range of annual recharge, with a maximum recharge volume of 283,233 AFY in 2006 and no recharge occurring in the dry years of 2008 and 2009. The average rate of recharge for managed recharge was 37 AFY/ac, but the actual rate of recharge is variable over time and project, ranging from 0 AFY/ac in most projects in 2008 to 180.1 AFY/ac in 2006 for the Kern Delta Water District recharge ponds.

Canal, stream, and river seepage results in significant recharge to the aquifer, and this source of recharge is generally considered to be a managed recharge source, in addition to the projects listed above. The major unlined waterways in the KRWCA area are shown on **Figure 8-1**. The rates of loss to recharge from these waterways are dependent on the length of the canal and the total loss observed (**Table 8-2**). The highest volume of loss occurs along the Kern River, but the highest rate of loss occurs along the City of Bakersfield Carrier Canal, as shown in **Table 8-2**.

The managed recharge and waterway loss data presented here is from reporting by individual agencies and from the Kern River Hydrographic Annual Reports prepared annually by the City of Bakersfield in cooperation with the Kern River Watermaster (2006 through 2010). In-lieu recharge is a management practice wherein water from an alternative surface water source, that is normally unavailable, is provided to groundwater users to offset pumping. This practice does not actually result in increased recharge to groundwater or offset 100 percent of groundwater use, so it is not considered an actual managed recharge source and is not included in **Table 8-2**.

The managed recharge projects contribute relatively high quality water to groundwater. The exact benefit and extent of this high quality recharge is variable and cannot easily be quantified, but should be considered as an element that could improve water quality when delineating areas of groundwater vulnerability.

## 8.4 Managed Wetlands

The Kern National Wildlife Refuge (**KNWR**) is an area of restored and preserved wetland habitat that existed historically in the area near the Kern River prior to intense farming. The majority of the water available to the KNWR for wildlife habitat is available in the fall and winter. These habitat areas, including wetlands, are managed by the United States Fish and Wildlife Service (**USFWS**) who uses Central Valley Project refuge supplies for irrigation and ponding. The habitat areas are divided into the following categories:



## Section Eight: Recharge to Groundwater Groundwater Quality Assessment Report

---

- Seasonal wetlands: timothy;
- Seasonal wetlands: smartweed;
- Seasonal wetlands: watergrass;
- Permanent wetlands;
- Semi-permanent wetlands;
- Riparian;
- Irrigated pasture;
- Upland; and,
- Seasonal wetlands (no summer water).

The most predominant types of managed wetlands are timothy seasonal wetlands (2,096 acres) and seasonal wetlands with no summer water (3,795 acres) (Todd Engineers, 2012). In 2009, timothy seasonal wetlands had a total delivered water rate of 6,498 AFY and an estimated seepage rate of 1.20 AFY/ac. The seasonal wetlands with no summer water have an average delivered water total of 11,385 AFY and also have a seepage rate of 1.20 AFY/ac. On average, 19,331 AFY of water is delivered to the managed wetlands.

The duration of the flooding depends on type of water supply, with the goal of 5,900 acres being flooded infrequently (1 year in 10), 4,830 acres flooded on an intermediate basis (2 years in 10), and 2,110 acres flooded frequently (5 years in 10).

The geology of these managed wetlands is comprised of an upper layer of clay overlying a lower layer of sandy loam, clay loam, and fine sandy loam. These areas often have a seasonally high water table and have low soil permeability.

The managed wetlands may also receive return flows from agricultural fields in the early water delivery season which may contain high levels of nutrients and salt loading that often cause algal growth in the wetlands. The soils in these areas are also strongly alkaline and in some areas contain high boron. These water quality issues require water quality monitoring and frequent flushing of the wetlands for maintenance, as controlled by USFWS.

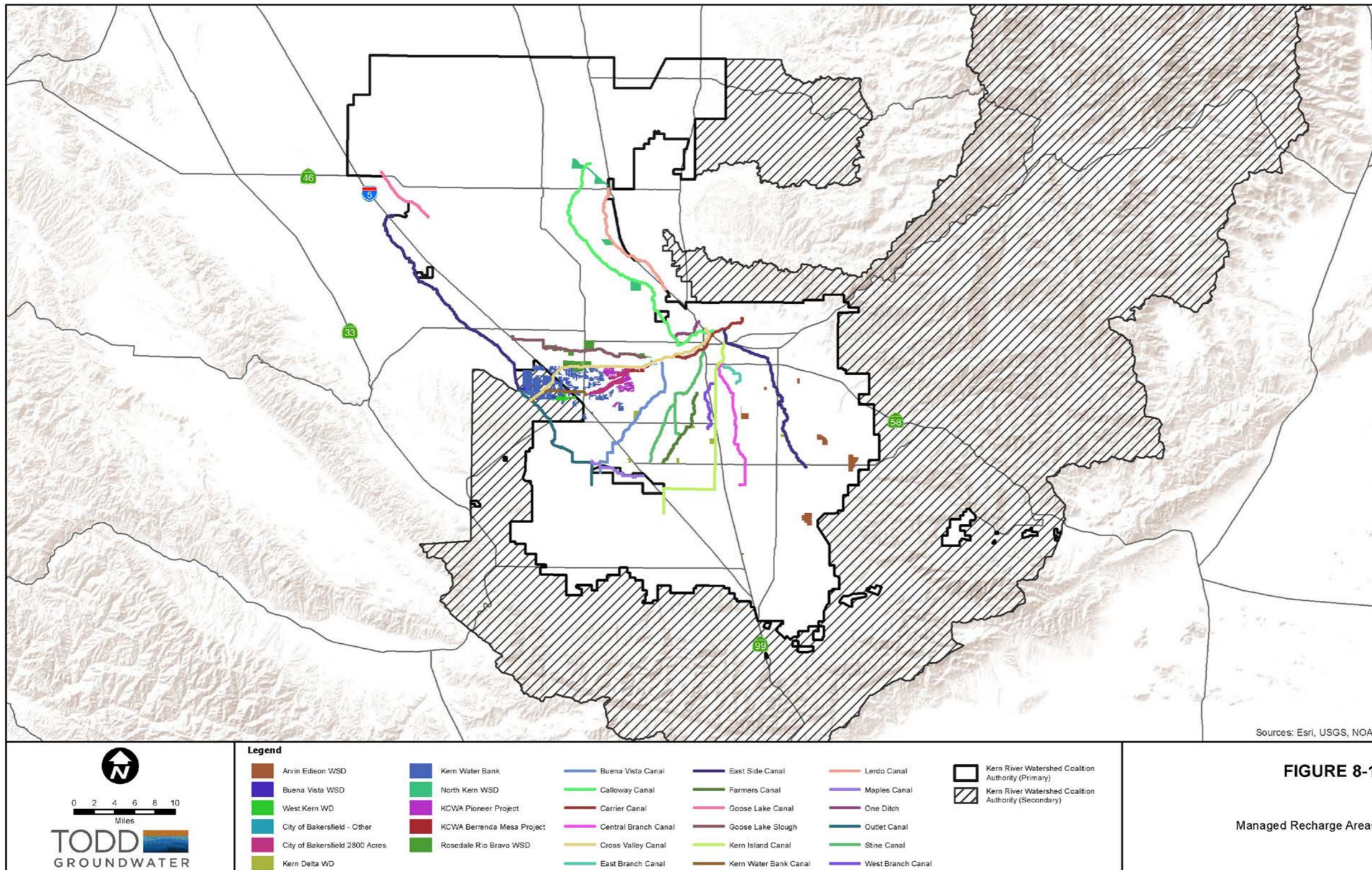

**FIGURE 8-1**

Managed Recharge Areas

Figure 8-1. Managed Recharge Areas



Table 8-1. Managed Groundwater Recharge in KRWCA

Managed Groundwater Recharge in KRWCA									
Agency	Project	Area (acres)	2006	2007	2008	2009	2010	Average Annual Recharge	Average Recharge (AFY/acre)
Arvin-Edison Water Storage District	Recharge Ponds	2,068	N/A	N/A	N/A	N/A	N/A	N/A	N/A
Buena Vista Water Storage District	Elk Pen	186	28,519	0	0	3,000	25,545	11,413	61
City of Bakersfield	2800 Acres	1,749	81,521	4,495	0	0	7,039	18,611	11
	Other	46	5,174	2,463	1,613	2,097	3,606	2,991	65
Kern County Water Agency	Pioneer	1,259	61,228	4,813	0	0	0	13,208	10
	Berrenda Mesa	210	26,229	2,098	0	0	0	5,665	27
	Kern River Channel	N/A	825	0	0	0	0	165	N/A
Kern Delta Water District	Recharge Ponds	226	40,775	0	0	0	82,363	24,628	109
Kern Water Bank	Kern Water Bank	7,530	283,233	16,728	0	0	33,131	66,618	9
North Kern Water Storage District	Poso Creek and Recharge Ponds	1,892	164,940	30,151	2,487	14,156	27,615	47,870	25
Rosedale Rio-Bravo Water Storage District	Recharge Ponds	2,697	147,151	3,200	0	2,354	141,521	58,845	22
Semitropic Water Storage District	Southern Ponds	N/A	1,019	211	0	0	625	371	N/A
West Kern Water District	Recharge Ponds	529	23,954	3,923	3,318	13,244	26,061	14,100	27

All values in acre-feet per year (AFY), unless otherwise noted.



Table 8-2. Unlined Canal and River Losses to Recharge in KRWCA

Managed Groundwater Recharge in KRWCA									
Agency	Canal Name	Total Canal Length (ft)	2006	2007	2008	2009	2010	Average	Average Recharge per Mile (AFY/mi)
Buena Vista Water Storage District	Maples	33,440	1,335	0	0	0	0	267	42
	Main Bypass Canal	223,789	0	191	187	2,286	1,159	765	18
	Outlet Canal	35,626	15,366	8,069	10,579	3,881	12,608	10,101	1,497
	Minor Canals	46,735	12,934	7,710	8,085	11,564	13,868	10,832	1,224
City of Bakersfield	Cross Valley Canal	80,704	0	0	0	383	205	118	8
	KRCI Ditch	19,302	1,685	896	922	890	640	1,007	275
	Carrier Canal	3,088	7,013	5,071	5,510	7,917	6,718	6,446	11,022
Kern Delta Water District	Eastside	48,022	1,580	1,903	3,712	3,345	6,719	3,452	380
	Farmers	125,379	3,912	680	2,565	2,068	6,887	3,222	136
	Buena Vista	125,379	6,921	2,594	4,490	7,032	15,746	7,357	310
	Central Branch	103,307	12,211	12,437	11,314	10,379	16,568	12,582	643
	Kern Island Canal	19,270	17,197	17,515	15,934	14,616	23,332	17,719	4,855
	Stine Canal	72,201	24,276	4,462	11,770	18,640	35,742	18,978	1,388
North Kern Water Storage District	Calloway Canal	138,420	22,592	642	2,166	2,163	23,739	10,260	391
	Lerdo Canal	71,442	1,528	1,039	943	964	1,154	1,126	83
Kern River		124,834	90,728	11,658	10,863	12,244	95,296	44,158	1,868

All values in acre-feet per year (AFY), unless otherwise noted.

# Appendix E: List of Individuals and Entities that Provided Comments on Draft SWRP



## List of Individuals and Entities that Provided Comments on Draft SWRP

The Draft Kern SWRP was distributed by email and posted on to the Kern IRWMP website ([www.kernirwmp.com](http://www.kernirwmp.com)) on October 21, 2016 for a three-week public review period. Public comments were due by November 14, 2016. During that time, a public meeting was held on November 9, 2016 with a group discussion regarding additions and revisions to the draft. In addition, comments were received separately from the following entities and individuals:

- Poso Creek IRWMP Regional Water Management Group – Signed by Ram Venkatesan, Vice Chairman, on behalf of the Poso Creek IRWMP RWMG, following a discussion at their public meeting held on November 1, 2016
- City of Bakersfield, Water Resources Department – Signed by Colin L. Pearce, Special Water Counsel with Duane Morris LLP on behalf of the City), dated November 14, 2016
- GEI Consultants – Sam Schaefer, Facilitator with Poso Creek IRWMP, dated November 2, 2016



Fresno • Clovis • Visalia • Bakersfield • Modesto • Los Banos • Chico • Merced  
[www.ppeng.com](http://www.ppeng.com) • [info@ppeng.com](mailto:info@ppeng.com)

## **APPENDIX J**

### **Poso Creek IRWM Group Drought Contingency Plan**

The Poso Creek IRWM Group Drought Contingency Plan is currently under development and is anticipated to be finished by April 2021. When finished, it will be added here as Appendix J to the 2019 IRWM Plan Update.



## Water Districts within the Poso Creek Region

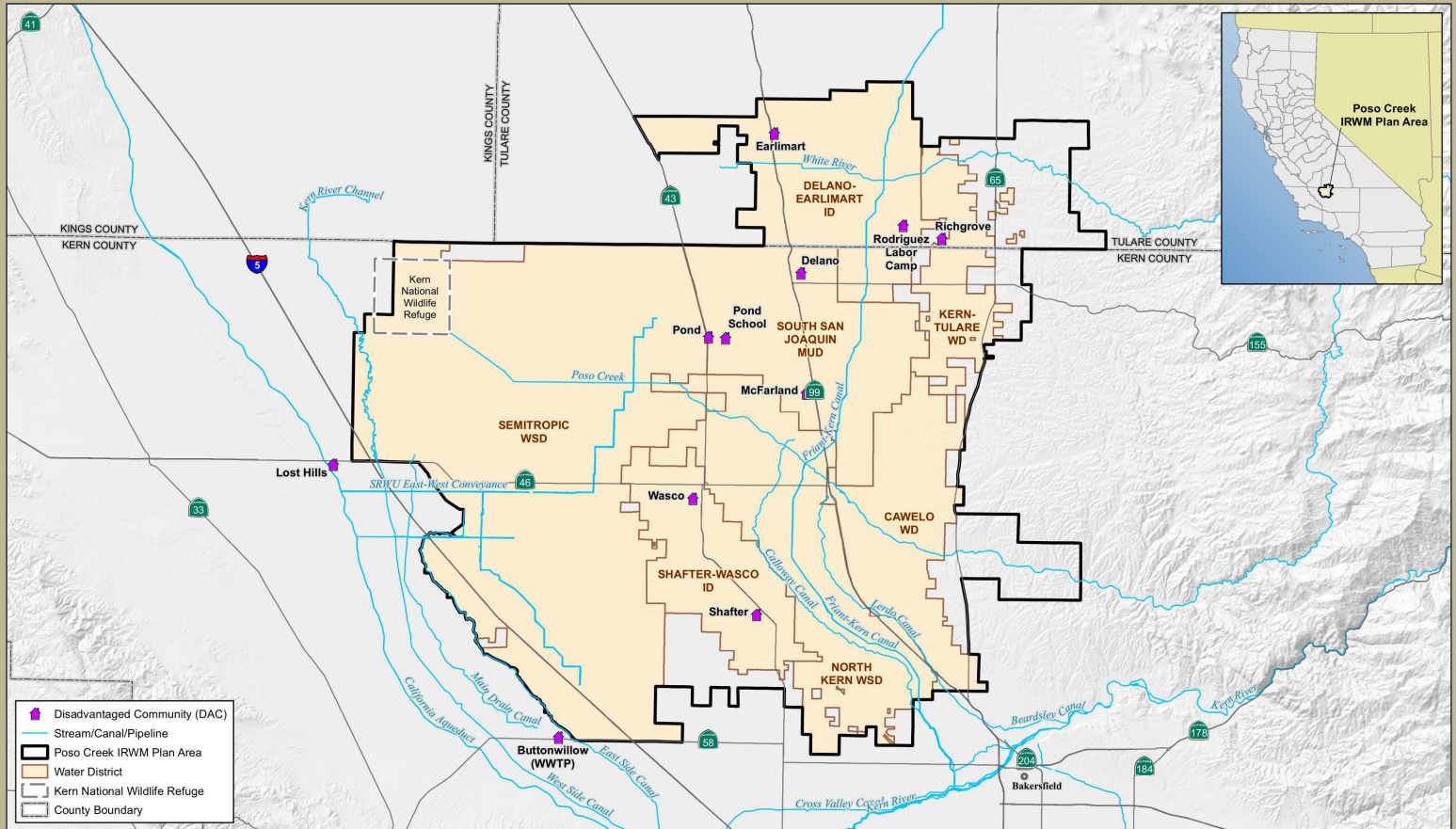

Please contact Isela Medina, IRWM Group Representative, with the Semitropic Water Storage District at (661) 758-5113 for information or to answer questions on behalf of the following eight entities:



Jason Gianquinto  
General Manager  
Semitropic Water Storage District



Richard Diamond  
General Manager  
North Kern Water Storage District



David R. Ansolabehere  
General Manager  
Cawelo Water District



Brian Hockett  
District Manager  
North West Kern Resource Conservation District



Steven C. Dalke  
General Manager  
Kern-Tulare Water District



Dana S. Munn  
General Manager  
Shafter-Wasco Irrigation District



Roland Gross  
General Manager  
Southern San Joaquin Municipal  
Utility District



Eric Quinley  
General Manager  
Delano-Earlimart Irrigation District